

# Sleep.8

Good Sleep Changes Everything

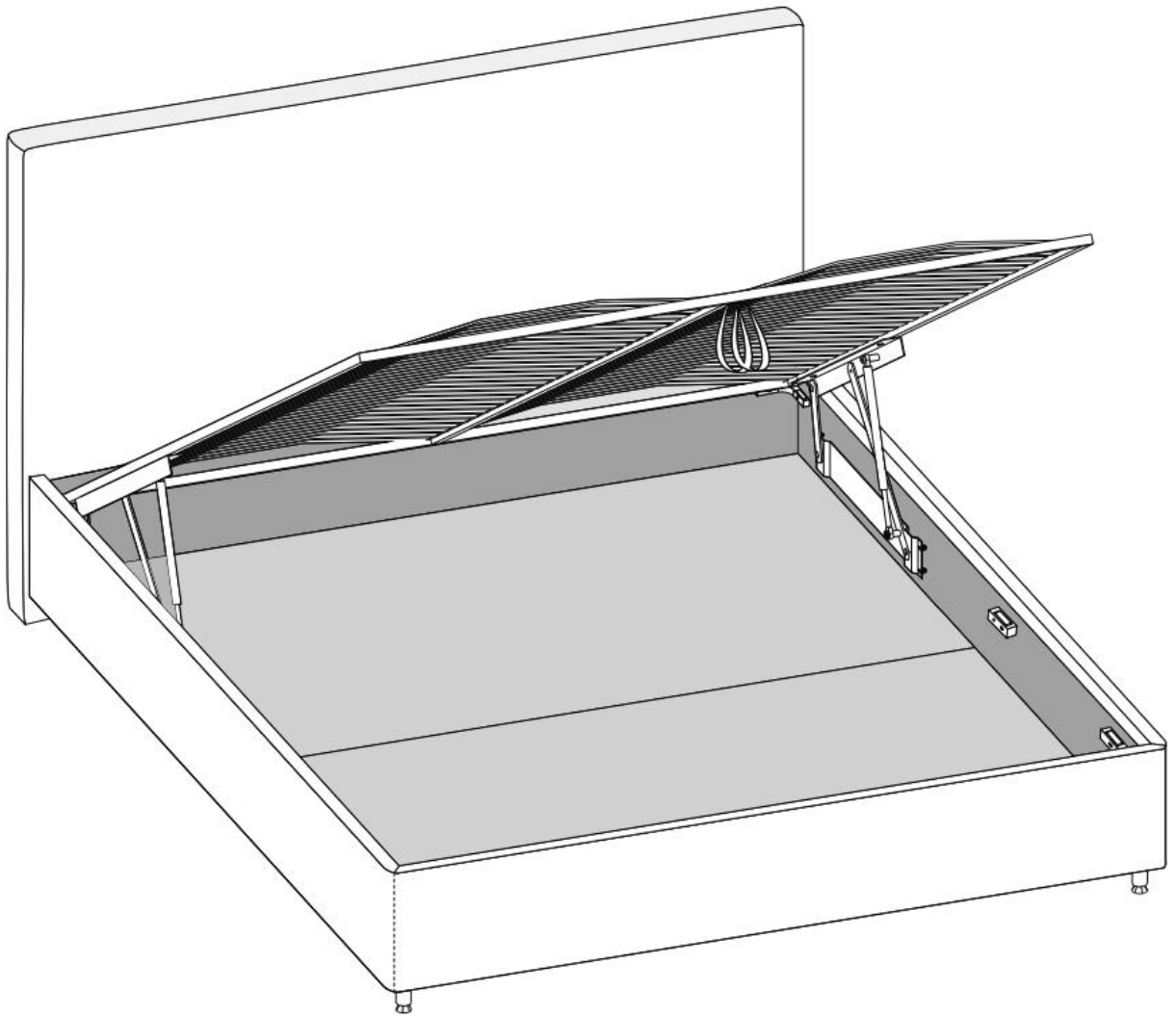

## FURNITURE ASSEMBLY INSTRUCTIONS



Instrucciones de montaje | Manual de montagem de moveis |  
Möbelmontierungsanweisungen | Οδηγίες συναρμολόγησης  
επίπλων | Mēbeļu montāžas instrukcijas | Instrucțiuni de  
asamblarea mobilierului | Mööbli kokkupanemise juhend



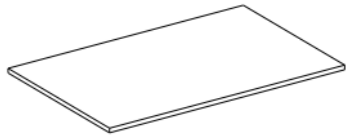

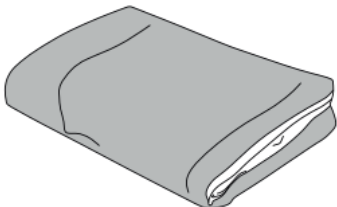
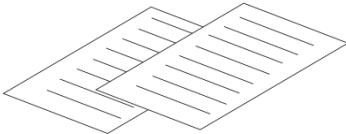
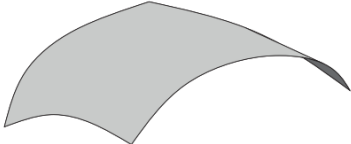

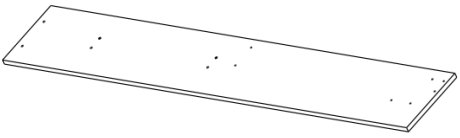
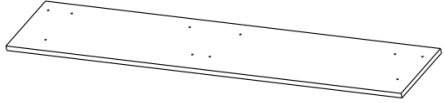
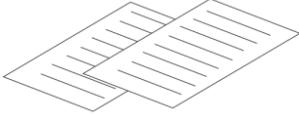
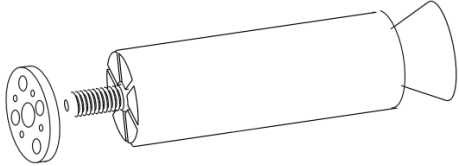
Bed with a lifting mechanism | Cama com mecanismo de elevação | Cama com mecanismo de elevación | Bett mit der Hebevorrichtung | Κρεβάτι με ανυψωτικό μηχανισμό | Gulta ar pacelšanas mehānismu | Pat cu mecanism de ridicare | Voodi tõstemehhanismiga

**Bed Parts list / Lista de peças / Listtado de componentes de la cama / Komplettierungsliste des bettes / Λίστα με υλικό κρεβατιού /  
Gultas komplektācijas saraksts / Lista pachetelor patului / Voodi komplektsus**

Package	Part	Article	Name	Quantity
<b>Package No. 1 /</b> Embalaje no. 1 / Embalagem nº 1 / Verpackung №1 / Συσκευασία υπ'άρ. 1 / Iepakojums Nr. 1 / Pachetul nr. 1 / Pakend nr 1		<b>K01</b>	<b>Headboard /</b> Respaldo / Cabeceira / Lehne / Πίσω στήριγμα / Atzveltne / Tāble / Seljatugi	1
		<b>K05</b>	<b>Bottom of a Storage Box /</b> Fondo del cajón / Fundo da gaveta / Boden der Aufbewahrungsbox / Κάτω μέρος του λινού συρταριού / Veļas kastes dibens / Partea de jos a cutiei de lenjerie / Linakasti pōhi	2
		<b>K09</b>	<b>Case for Rails (*for beds with a removable case) /</b> Funda para el bastidor (*para camas con funda extraíble) / Capa para as barras (*para as camas com capa removível) / Bezug für Zargen (Nur für Betten mit einer Hebevorrichtung und Zargen, die völlig mit Padding bezogen sind) / Κάλυμμα για το σφάγιο / Apaļturu pārvalks / Acoperire pentru cadru (*pentru paturi cu acoperire detașabilă) / Kate tsargadele (*eemaldatava kattega vooditele)	1
			<b>User guide /</b> Instrucciones de uso / Instrucciones para el Ensamble / Bedienungsanleitung / Εγχειρίδιο χρήστη / Lietotāja rokasgrāmata / Instrucțiuni de utilizare / Kasutusjuhend	1
			<b>Sample of fabric (*or sewn into cover for braces see pt. p.38) /</b> Muestra de tejido (*puede estar cosida a la funda del bastidor, véase paso 38) / Amostra de material (ou cosido na capa, ver ponto 38) / Stoffmuster (*oder in den Bezug der Zargen eingenäht, siehe Punkt 38) / Δείγμα υφάσματος (*ή ραμμένο στο κάλυμμα του πλαισίου, βλέπε παράγραφο 38) / Auduma paraugs (*vai iēsūts apaļturu pārvalkā sk. p. 38) / Eșantion de țesătură (*sau este cusut în acoperirea cadrului, vezi punctul 38) / Kanga näidis (*või õmmeldud tsargade katesse, vt punkt 38)	1

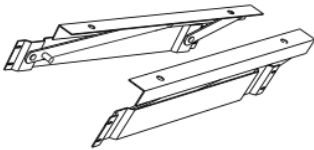
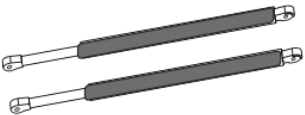
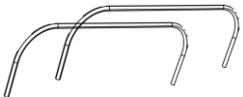

<p><b>Package No. 2 /</b>  Embalaje no. 2 /  Embalagem nº 2 /  Verpackung №2 /  Συσκευασία υπ'άρ. 2 /  Iepakojums Nr. 2 /  Pachetul nr. 2 /  Pakend nr 2</p>		<p><b>K02</b></p>	<p><b>Side Rail /</b>  Lateral del bastidor /  Barra lateral / Seitenzarge /  Πλαϊνό σφάγιο / Sānu apaļtapa /  Cadru lateral / Külgsarga</p>	<p>2</p>
		<p><b>K03</b></p>	<p><b>Footboard brace /</b>  Pie del bastidor / Traverssa peseira /  Zarge des Fußendes / Μεσαίο σφάγιο /  Vidējā apaļtapa / Cadru piciorului / Jalutse tsarga</p>	<p>1</p>
			<p><b>Assembly Instructions /</b>  Instrucciones de montaje / Manual de montage /  Montierungsanweisungen / Οδηγίες συναρμολόγησης /  Montāžas darbu instrukcija /  Instrucțiuni de asamblarea</p>	<p>1</p>
<p><b>Package with Fittings /</b>  Paquete con accesorios /  Saco com acessórios /  Verpackung  mit Beschlägen /  Πακέτο εξαρτημάτων  επίπλων /  Soma ar piederumiem /  Pachet cu accesorii /  Pakend furnituuriga</p>			<p><b>Legs.</b> Leg configuration depends on the bed model demonstrated as a sample in the store or on the web-side (please see the leg component list) /  <b>Pata.</b> El diseño de las patas depende del modelo de cama mostrado en la tienda o el sitio web (Véase el listado de patas y sus componentes) /  <b>Pés.</b> Modificação dos pés depende do modelo da cama, fornecido como exemplo no salão ou no site (ver lista de peças dos pés) /  <b>Füße.</b> die Modifikation der Füße hängt vom Bettmo-del ab, das als muster im Möbelsalon oder auf der Webseite präsentiert wurde. (siehe die Komplettierungsliste der Füße) /  <b>Πόδια.</b> Η τροποποίηση των ποδιών εξαρτάται από το μοντέλο του κρεβατιού που παρουσιάζεται ως δείγμα στο σαλόνι ή στον ιστότοπο (βλ. τη λίστα υπάρχωντων ποδιών) /  <b>Kājiņa.</b> Kājiņu modifikācija ir atkarīga no apaļtapa secības un veida (skatīt kājiņu komplektācijas sarakstu) /  <b>Picioare.</b> modificarea picioarelor depinde de modelul de pat prezentat ca eşantion în salon sau pe site (a se vedea lista completă a picioarelor) /  <b>Jalad.</b> Jalade modifikatsioon oleneb salongis või kodulehel näidisenä toodud voodi mudelist (vt jalgade kompleksus)</p>	<p>1 Set  1 Conjunto  1 Conjunto  1 Set  1 σετ (σειρά)  1 kompl  (komplekts)  1 set</p>
		<p><b>K06</b></p>	<p><b>Grip Strap of the Lift Mechanism /</b>  Tirador de tela para el mecanismo de elevació /  Alça de elevação /  Griff-Gurt der Hebevorrichtung /  Λαβή-μιάντα μηχανισμού ανύψωσης /  Pacelšanas mehānizma siksna – rokturis /  Mâner-curea a mecanismului de ridicare /  Tõstemehhanismi äpideme-põhn</p>	<p>2</p>



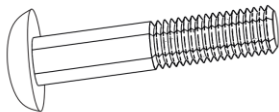
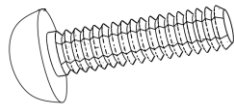
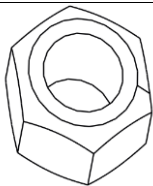
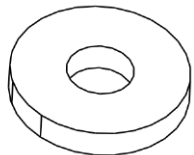
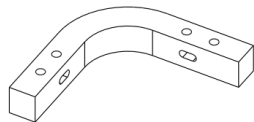
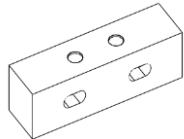
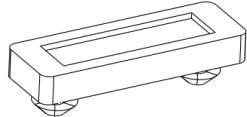
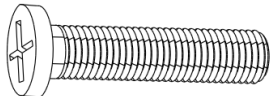
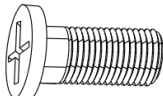

**Bed Parts list / Lista de peças / Listtado de componentes de la cama / Komplettierungsliste des bettes / Λίστα με υλικό κρεβατιού /  
Gultas komplektācijas saraksts / Lista pachetelor patului / Voodi kompleksus**

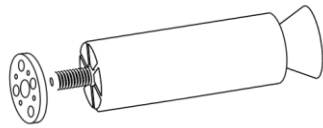

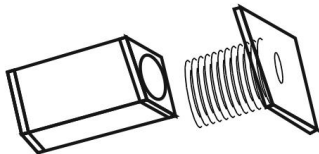
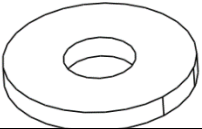
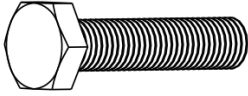
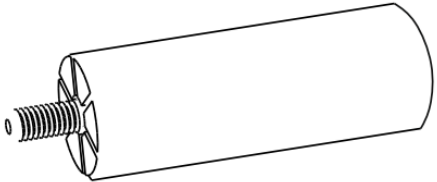

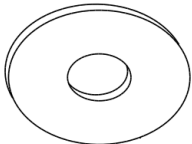
<b>Package</b>	<b>Part</b>	<b>Article</b>	<b>Name</b>	<b>Quantity</b>
<b>Package No. 3. Bed Base/</b> Embalaje no. 3. Estrado da cama / Embalagem nº 3. Somier de la cama / Verpackung №3. Metallrahmen / Συσκευασία υπ'άρ. 3. Βάση κρεβατιού / Iepakojums Nr. 3. Gultas pamatne / Pachetul nr. 3. Baza patului / Pakend nr 3. Voodi alus		P01	<b>Bed Base /</b> Estrado da cama / Somier / Metallrahmen / Βάση κρεβατιού / Gultas pamatne / Baza patului / Voodi alus	1
		P02	<b>Long Fastener /</b> Betonilha longitudinal / Barra de unión lateral / Längsverbinding / Διαμήκη στήριγμα / Gareniskā savilce / Šapā longitudinalā / Pikisuunaline pinguti /	2
		P03	<b>Bar /</b> Travessa / Travesano / Schiebleiste / Σιδηροτροχιά / Šķērssijs / Traversă / Traavers	1
<b>Package No. 3. Package with Fittings No. 1 /</b> Embalaje no. 3. Paquete con accesorios no. 1 / Embalagem nº 3. Saco com acessórios nº 1 / Verpackung №3. mit Beschlägen №1 / Συσκευασία υπ'άρ. 3. Πακέτο εξαρτημάτων επίπλων υπ'άρ. 1 / Iepakojums Nr. 3. Soma ar piederumiem Nr. 1 / Pachetul nr. 3. Pachet cu accesorii nr. 1 / Pakend nr 3. Pakend furnituuriga nr 1		PF10	<b>Lift mechanisms / left and right /</b> Mecanismos de elevación izquierdo y derecho (articulación) / Equipamento de elevação / Hebevorrichtungen die linke und die rechte / Μηχανισμοί ανύψωσης αριστερά και δεξιά / Pacelšanas mehānismi pa kreisi un pa labi / Mecanisme de ridicare stânga și dreapta / Vasak- ja parempoolsed tõstemehhanismid	1 Set 1 Conjunto 1 Conjunto 1 Set 1 σετ (σειρά) 1 kompl (komplekts) 1 set
		PF17	<b>Gas shock absorber(with swivel) /</b> Amortiguador de gas (articulación) / Amortecedores a gás (dobradiça) / Gasfeder (Gelenk) / Αμορτισέρ αερίου (μεντεσέ) / Gāzes amortizators (eņģe) / Amortizor cu gaz (telescop) / Gaasiamortisaator (šarniir)	2
		PF14	<b>Mattress brackets (*may have different configuration) /</b> Sostenedores de colchón / Soportes para colchões (articulación) / Matratzehalter / Στήριγμα στρωμάτων / Matraču turētāji / Suporturi pentru saltele (*pot fi de diferite configurații) / Madratsihoidjad (*võivad olla erineva konfiguratsiooniga)	2
		PF31		2

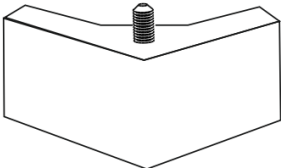
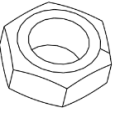
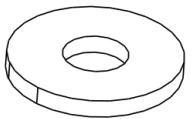
		PF01	<b>Bolt M8x45 (round head) /</b> Perno M8x45 (cabeza) / Tornillo M8x45 / Bolzen M8x45 / Μπουλόνι M8x45 (κεφάλι) / Skrūve M8x45 (cepure) / Şurub M8x45 (cap) / Polt M8x45 (pea)	4
		PF04	<b>Screw M6x20 /</b> Perno M6x20 / Tornillo M6x20 / Bolzen M6x20 / Βίδα M6x20 / Skrūve M6x20 / Şurub M6x20 / Kruvi M6x20	8
		PF06	<b>Nut M8 /</b> Tuerca M8 / Porca de parafuso M8 / Mutter M8 / Καρύδι M8 / Uzgrieznis M8 / Piuliņa M8 / Mutter M8	4
		PF08	<b>Washer M8 /</b> Arandela M8 / Arruela M8 / Scheibe M8 / Πλυντήριο M8 / Paplāksne M8 / Şaibă M8 / Seib M8	4
<b>Package No. 3. Package with Fittings No. 2 /</b> Embalaje no. 3. Paquete con accesorios no. 2 / Embalagem n° 3. Saco com acessórios n° 2 / Verpackung №3. mit Beschlägen №2 / Συσκευασία υπ'άρ. 3. Πακέτο εξαρτημάτων επίπλων υπ'άρ. 2 / Ierakojumš Nr. 3. Soma ar piederumiem Nr. 2 / Pachetul nr. 3. Pachet cu accesorii nr. 2 / Pakend nr 3. Pakend furnituuriga nr 2		P04	<b>Angle Brace /</b> Cantoneira / Soporte angular / Seitenverbindung / Γωνιακό στήριγμα / Stūra savilce / Şapă de colt / Nurgapinguti	4
		P05	<b>Edge /</b> Prateleira / Soporte recto / Schenkel / Ράφι / Plaukts / Raft / Riil	4
		PF09	<b>Rubber Damper /</b> Amortecedor de borracha / Amortiguador de caucho / Gummidämpfer / Καουτσούκ αποσβεστήρας / Gumijas amortizators / Amortizor de cauciuc / Kummist amortisaator /	12
		PF02	<b>Screw M8x50 /</b> Perno M8x50 / Tornillo M8x50 / Bolzen M8x50 / Βίδα M8x50 / Skrūve M8x50 / Şurub M8x50 / Kruvi M8x50	36
		PF03	<b>Screw M8x20 /</b> Perno M8x20 / Tornillo M8x20 / Bolzen M8x20 / Βίδα M8x20 / Skrūve M8x20 / Şurub M8x20 / Kruvi M8x20	4

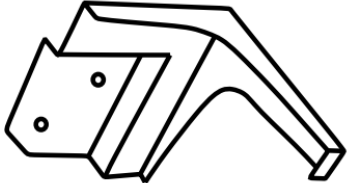
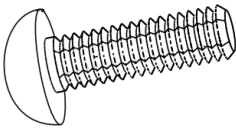
**Leg Parts List / Lista de peças para os pés / Listado de patas y sus componentes / Komplettierungsliste der Füße / Λίστα με υλικό Πόδια / Kājiņas komplektācijas saraksts / Lista pachetelor de picioare / Jalgade kompleksus**

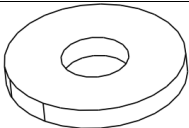
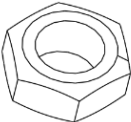

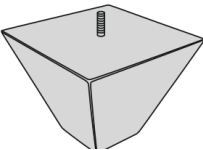
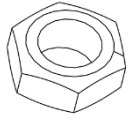
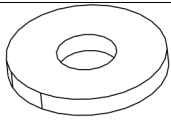
<b>Package</b>	<b>Part</b>	<b>Article</b>	<b>Name</b>	<b>Quantity</b>
<b>Leg Parts No.1 /</b> Conjunto de pés №1 / Modelo de pata nº 1 / Komplettierung der Füße №1 / Επιλογή για σετ ποδιών υπ' άρ. 1 / Kājiņu komplektācijas variants Nr. 1 / Set complet de picioare nr. 1 / Jalgade kompleksuse valik nr 1		KF16	<b>Bed Leg Supporting Leg Chrome Boyard-100 /</b> Pé para cama Pé-suporte cromo Boyard-100 / Pata para cama de cromo Boyard-100 / Bettfuß Stütze Chrom-Bojard h-100 / Υποστήριξη χρώμιο Boyard-100 / Balsts hrom Bojard-100 / Picioar-suport crom Boyard-100 / Voodijalg Tugijalg kroom Bojard-100	2
		KF29	<b>Allen Key /</b> Chave Allen / Llave Allen / Inbus-Schlüssel / Εξάγωνο κλειδί / Atslēga sešstūra / Cheie hexagonală / Kuuskantvõti	1
<b>Leg Parts No.2 /</b> Conjunto de pés №2 / Modelo de pata nº 2 / Komplettierung der Füße №2 / Επιλογή για σετ ποδιών υπ' άρ. 2 / Kājiņu komplektācijas variants Nr. 2 / Set complet de picioare nr. 2 / Jalgade kompleksuse valik nr 2		KF36	<b>Plastic Leg Square /</b> Pé plástico cuadrado / Pata cuadrada de plastic / Plastikfuß Quadrat / Πλαστικό τετράγωνο πόδι / Plastikāta kājiņa kvadrāts / Picioar pătrat din plastic / Plastikust jalg ruut	2
		KF40	<b>Washer M8 /</b> Porca M8 / Arandela M8 / Scheibe M8 / Πλυντήριο M8 / Paplāksne M8 / Şaibă M8 / Seib M8	2
		KF38	<b>Bolt M8x10 /</b> Perno M8x10 / Tornillo M8x10 / Bolzen M8x10 / Μπουλόνι M8x10 / Skrūve M8x10 / Şurub M8x10 / Polt M8x10	2
<b>Leg Parts No.3 /</b> Conjunto de pés №3 / Modelo de pata nº 3 / Komplettierung der Füße №3 / Επιλογή για σετ ποδιών υπ' άρ. 3 /		KF54	<b>Bed Leg No.1156 Chrome h-150 (pin 8 mm) /</b> Pés para as camas N°1156 cromo h-150 (8mm) / Pata para cama nº 1156 de cromo h-150 (diém. 8 mm) / Bettfuß №1156 Chrom h-150 / Πόδι για κρεβάτια χρώμιο h-150 (φουρκέτα 8mm) / Gultas kājiņa hroms h-150 (tapskrūve 8mm) / Picioar pentru paturi nr. 1156 crom h-150 (pin 8 mm) / Voodi jalg nr 1156 kroom h-150 (tikkpolt 8 mm)	2

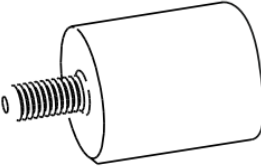
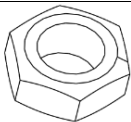

<p>Kājiņu komplektācijas variants Nr. 3 / Set complet de picioare nr. 3 / Jalgade kompleksuse valik nr 3</p>		KF40	<p><b>Washer M8 DIN 126 /</b> Porca M8 DIN 126 / Arandela M8 DIN 126 / Scheibe M8 DIN 126 / Πλυντήριο M8 DIN 126 / Paplāksne M8 DIN 126 / Şaibā M8 DIN 126 / Seib M8 DIN 126</p>	2
		KF39	<p><b>Nut M8 DIN 936 /</b> Tuerca M8 DIN 936 / Porca de parafuso M8 DIN 936 / Mutter M8 DIN 936 / Καρύδι M8 DIN 936 / Uzgrieznis M8 DIN 936 / /  Piuliţă M8 DIN 936 / Mutter M8 DIN 936</p>	2
<p><b>Leg Parts No.4 /</b> Conjunto de pés №4 / Modelo de pata n° 4 / Komplettierung der Füße №4 / Επιλογή για σετ ποδιών υπ' άρ. 4 / Kājiņu komplektācijas variants Nr. 4 / Set complet de picioare nr. 4 / Jalgade kompleksuse valik nr 4</p>		KF31	<p><b>Angled Wooden Leg h-97 /</b> Pé de madeira h-97 angular / Pata esquinera de madera h-97 / Holzfuß h-97 Seitenfuß / Ξύλινο πόδι γωνίας h-97 / Koka kājiņa h-97 stūra / Picior din lemn h-97 unghiular / Puidust jalg h-97 nurgeline</p>	2
		KF39	<p><b>Nut M8 DIN 936 /</b> Tuerca M8 DIN 936 / Porca de parafuso M8 DIN 936 / Mutter M8 DIN 936 / Καρύδι M8 DIN 936 / Uzgrieznis M8 DIN 936 Piuliţă M8 DIN 936 / Mutter M8 DIN 936</p>	2
		KF40	<p><b>Washer M8 DIN 126 /</b> Porca M8 DIN 126 / Arandela M8 DIN 126 / Scheibe M8 DIN 126 / Πλυντήριο M8 DIN 126 / Paplāksne M8 DIN 126 / Şaibā M8 DIN 126 / Seib M8 DIN 126</p>	2
		KF18	<p><b>Felt Damper /</b> Amortecedor de feltro / Fieltro protector / Filziger Dampfer / Αποσβεστήρας από τσόχα / Filca amortizator / Amortizor din pãslă / Vildist amortisaator</p>	4
<p><b>Leg Parts No.5 /</b> Conjunto de pés №5 / Modelo de pata n° 5 / Komplettierung der Füße №5 / Επιλογή για σετ ποδιών υπ' άρ. 5 / Kājiņu komplektācijas variants Nr. 5 / Set complet de picioare nr. 5 / Jalgade kompleksuse valik nr 5</p>		KF41	<p><b>Decorative Support h-130 Chrome /</b> Suporte decorativo h-130 cromo / Soporte decorative de cromo h-130 / Dekorative Stütze h-130 Chrom / Διακοσμητικό στήριγμα χρώμιο h-130 / Dekoratīvs balsts h-130 hroms / Suport decorativ h-130 crom / Dekoratiivne tugi h-130 kroom</p>	2
		KF43	<p><b>Screw M8x20 DIN 967 /</b> Perno M8x20 DIN 967 / Tornillo M8x20 DIN 967 / Bolzen M8x20 DIN 967 / Βίδα M8x20 DIN 967 / Skrūve M8x20 DIN 967 / Şurub M8x20 DIN 967 / Kruvi M8x20 DIN 967</p>	2

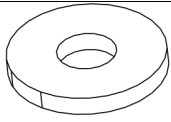
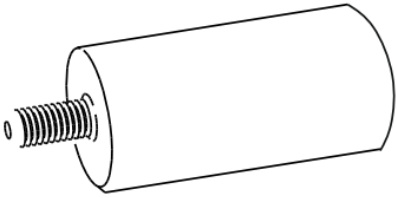
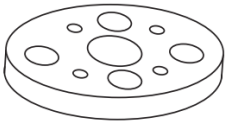
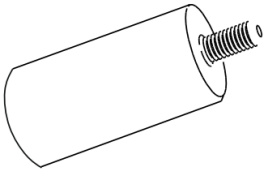
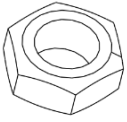
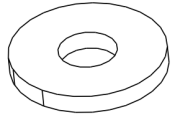
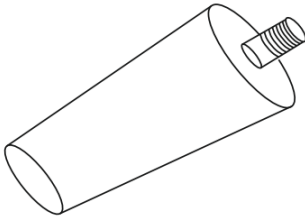
		KF42	<b>Washer M8 DIN 9021 /</b> Porca M8 DIN 9021 / Arandela M8 DIN 9021 / Scheibe M8 DIN 9021 / Πλυντήριο M8 DIN 9021 / Paplāksne M8 DIN 9021 / Şaibă M8 DIN 9021 / Seib M8 DIN 9021	2
		KF39	<b>Nut M8 DIN 936 /</b> Tuerca M8 DIN 936 / Porca de parafuso M8 DIN 936 / Mutter M8 DIN 936 / Καρύδι M8 DIN 936 / Uzgrieznis M8 DIN 936 / Piuliņa M8 DIN 936 / Mutter M8 DIN 936	2
		KF18	<b>Felt Damper /</b> Amortecedor de feltro / Fieltro protector / Filziger Dampfer / Αποσβεστήρας από τσόχα / Filca amortizators / Amortizor din pãslă / Vildist amortisaator	1
<b>Leg Parts No.6 /</b> Conjunto de pés №6 / Modelo de pata nº 6 / Komplettierung der Füße №6 / Επιλογή για σετ ποδιών υπ' άρ. 6 / Kājiņu komplektācijas variants Nr. 6 / Set complet de picioare nr. 6 / Jalgade kompleksuse valik nr 6		KF30	<b>Wooden Leg h-97 /</b> Pé de madeira h-97 / Pata de madera h-97 / Holzfuß h-97 / Ξύλινο πόδι h-97 / Koka kājiņa h-97 / Picior din lemn h-97 / Puidust jalg h-97	2
		KF39	<b>Nut M8 DIN 936 /</b> Tuerca M8 DIN 936 / Porca de parafuso M8 DIN 936 / Mutter M8 DIN 936 / Καρύδι M8 DIN 936 / Uzgrieznis M8 DIN 936 Piuliņa M8 DIN 936 / Mutter M8 DIN 936	2
		KF40	<b>Washer M8 DIN 126 /</b> Porca M8 DIN 126 / Arandela M8 DIN 126 / Scheibe M8 DIN 126 / Πλυντήριο M8 DIN 126 / Paplāksne M8 DIN 126 / Şaibă M8 DIN 126 / Seib M8 DIN 126	2
		KF18	<b>Felt Damper /</b> Amortecedor de feltro / Fieltro protector / Filziger Dampfer / Αποσβεστήρας από τσόχα / Filca amortizators / Amortizor din pãslă / Vildist amortisaator	2
		KF55	<b>Bed Leg 178 Chrome h-50 /</b> Pés para as camas 178 cromo h-50 / Pata para cama 178 de cromo h-50 / Bettfuß 178 Chrom h-50 / Πόδι για κρεβάτια 178 χρώμιο h-50 / Gultas kājiņa 178hroms h-50 / Picior pentru paturi 178 crom h-50 / Voodi jalg 178 kroom h-50	2
<b>Leg Parts No.7 /</b> Conjunto de pés №7 / Modelo de pata nº 7 / Komplettierung der Füße №7 / Επιλογή για σετ ποδιών υπ' άρ. 7 / Kājiņu komplektācijas variants Nr. 7 / Set complet de picioare nr. 7 /		KF39	<b>Nut M8 DIN 936 /</b> Tuerca M8 DIN 936 / Porca de parafuso M8 DIN 936 / Mutter M8 DIN 936 / Καρύδι M8 DIN 936 /Uzgrieznis M8 DIN 936 / Piuliņa M8 DIN 936 / Mutter M8 DIN 936	2

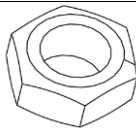
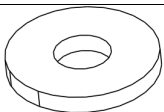

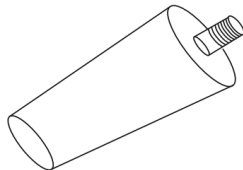
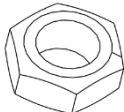
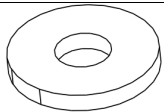
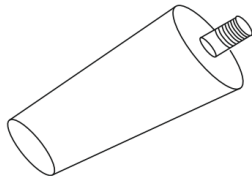
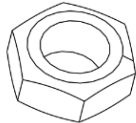
<p>Jalgade kompleksuse valik nr 7</p>		<p>KF40</p>	<p><b>Washer M8 /</b>  Porca M8 / Arandela M8 /  Scheibe M8 / Πλυντήριο M8 /  Paplāksne M8 / Şaibā M8 / Seib M8</p>	<p>2</p>
<p><b>Leg Parts No.8 /</b>  Conjunto de pés №8 /  Modelo de pata nº 8 /  Komplettierung der Füße №8 /  Επιλογή για σετ ποδιών υπ' άρ. 8 /  Kājiņu komplektācijas variants Nr. 8 /  Set complet de picioare nr. 8 /  Jalgade kompleksuse valik nr 8</p>		<p>KF69</p>	<p><b>Bed Leg h-120 /</b>  Pés para as camas h-120 / Pata para cama de h-120 /  Bettfuß h-120 / Πόδι για κρεβάτια h-120 /  Gultas kājiņa h-120 / Picioar pentru paturi h-120 /  Voodi jalg h-120</p>	<p>2</p>
<p><b>Leg Parts No.9 /</b>  Conjunto de pés №9 /  Modelo de pata nº 9 /  Komplettierung der Füße №9 /  Επιλογή για σετ ποδιών υπ' άρ. 9 /  Kājiņu komplektācijas variants Nr. 9 /  Set complet de picioare nr. 9 /  Jalgade kompleksuse valik nr 9</p>		<p>KF37</p>	<p><b>Decorative Nut /</b>  Anilha decorative / Tuerca decorative /  Dekorative Mutter / Διακοσμητικό Πλυντήριο /  Dekoratīvais Paplāksne / Piuližā dekoratīvā / Dekoratiivmutter</p>	<p>2</p>
<p><b>Leg Parts No.9 /</b>  Conjunto de pés №9 /  Modelo de pata nº 9 /  Komplettierung der Füße №9 /  Επιλογή για σετ ποδιών υπ' άρ. 9 /  Kājiņu komplektācijas variants Nr. 9 /  Set complet de picioare nr. 9 /  Jalgade kompleksuse valik nr 9</p>		<p>KF77</p>	<p><b>Bed Leg Chrome h-100 /</b>  Pés para as camas cromo h-100 / Pata para cama de cromo h-100 /  Bettfuß Chrom h-100 / Πόδι για κρεβάτια χρώμιο h-100 /  Gultas kājiņa hroms h-100 / Picioar pentru paturi crom h-100 /  Voodi jalg kroom h-100</p>	<p>2</p>
<p><b>Leg Parts No.10 /</b>  Conjunto de pés №10 /  Modelo de pata nº 10 /  Komplettierung der Füße №10 /  Επιλογή για σετ ποδιών υπ' άρ. 10 /</p>		<p>KF39</p>	<p><b>Nut M8 DIN 936 /</b>  Tuerca M8 DIN 936 / Porca de parafuso M8 DIN 936 /  Mutter M8 DIN 936 / Καρύδι M8 DIN 936 / Uzgrieznis M8 DIN 936 /  Piuližā M8 DIN 936 / Mutter M8 DIN 936</p>	<p>2</p>
<p><b>Leg Parts No.9 /</b>  Conjunto de pés №9 /  Modelo de pata nº 9 /  Komplettierung der Füße №9 /  Επιλογή για σετ ποδιών υπ' άρ. 9 /  Kājiņu komplektācijas variants Nr. 9 /  Set complet de picioare nr. 9 /  Jalgade kompleksuse valik nr 9</p>		<p>KF40</p>	<p><b>Washer M8 /</b>  Porca M8 / Arandela M8 /  Scheibe M8 / Πλυντήριο M8 /  Paplāksne M8 / Şaibā M8 / Seib M8</p>	<p>2</p>
<p><b>Leg Parts No.10 /</b>  Conjunto de pés №10 /  Modelo de pata nº 10 /  Komplettierung der Füße №10 /  Επιλογή για σετ ποδιών υπ' άρ. 10 /</p>		<p>KF80</p>	<p><b>Decorative Support 60*60*195 /</b>  Suporte decorativo 60*60*195 /  Soporte decorative de 60*60*195 / Dekorative Stütze 60*60*195 /  Διακοσμητικό στήριγμα 60*60*195 /  Dekoratīvs balsts 60*60*195 /  Suport decorative 60*60*195 / Dekoratiivne tugi 60*60*195</p>	<p>2</p>

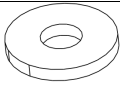
<p>Kājiņu komplektācijas variants Nr. 10 / Set complet de picioare nr. 10 / Jalgade kompleksuse valik nr 10</p>		KF39	<p><b>Nut M8 DIN 936 /</b> Tuerca M8 DIN 936 / Porca de parafuso M8 DIN 936 / Mutter M8 DIN 936 / Καρύδι M8 DIN 936 / Uzgrieznis M8 DIN 936 / Piuližā M8 DIN 936 / Mutter M8 DIN 936</p>	2
		KF40	<p><b>Washer M8 /</b> Porca M8 / Arandela M8 / Scheibe M8 / Πλυντήριο M8 / Paplāksne M8 / Şaibā M8 / Seib M8</p>	2
		KF81	<p><b>Felt Damper 20*20 /</b> Amortecedor de feltro 20*20 / Fieltro protector 20*20 / Filziger Dampfer 20*20 / Αποσβεστήρας από τσόχα 20*20 / Filca amortizators 20*20 / Amortizor din pāslā 20*20 / Vildist amortisaator 20*20</p>	2
<p><b>Leg Parts No.11 /</b> Conjunto de pés №11 / Modelo de pata nº 11 / Komplettierung der Füße №11 / Επιλογή για σετ ποδιών υπ' άρ. 11 / Kājiņu komplektācijas variants Nr. 11 / Set complet de picioare nr. 11 / Jalgade kompleksuse valik nr 11</p>		KF80	<p><b>Bed Leg h-120 /</b> Pés para as camas h-120 / Pata para cama de h-120 / Bettfoot h-120 / Πόδι για κρεβάτια h-120 / Gultas kājiņa h-120 / Păcior pentru paturi h-120 / Voodi jalg h-120</p>	2
		KF39	<p><b>Nut M8 DIN 936 /</b> Tuerca M8 DIN 936 / Porca de parafuso M8 DIN 936 / Mutter M8 DIN 936 / Καρύδι M8 DIN 936 / Uzgrieznis M8 DIN 936 / Piuližā M8 DIN 936 / Mutter M8 DIN 936</p>	2
		KF40	<p><b>Washer M8 /</b> Porca M8 / Arandela M8 / Scheibe M8 / Πλυντήριο M8 / Paplāksne M8 / Şaibā M8 / Seib M8</p>	2
<p><b>Leg Parts No.12 /</b> Conjunto de pés №12 / Modelo de pata nº 12 / Komplettierung der Füße №12 / Επιλογή για σετ ποδιών υπ' άρ. 12 / Kājiņu komplektācijas variants Nr. 12 / Set complet de picioare nr. 12 /</p>		KF130	<p><b>Decorative Support 60*45*120 /</b> Suporte decorativo 60*45*120 / Soporte decorativo de 60*45*120 / Dekorative Stiitze 60*45*120 / Διακοσμητικό στήριγμα 60*45*120 / Dekoratīvs balsts 60*45*120 / Suport decorative 60*45*120 / Dekoratiivne tugi 60*45*120</p>	2
		KF39	<p><b>Nut M8 DIN 936 /</b> Tuerca M8 DIN 936 / Porca de parafuso M8 DIN 936 / Mutter M8 DIN 936 / Καρύδι M8 DIN 936 / Uzgrieznis M8 DIN 936 / Piuližā M8 DIN 936 / Mutter M8 DIN 936</p>	2

Jalgade kompleksuse valik nr 12		KF40	<b>Washer M8 /</b> Porca M8 / Arandela M8 / Scheibe M8 / Πλυντήριο M8 / Paplāksne M8 / Şaibă M8 / Seib M8	2
		KF81	<b>Felt Damper 20*20 /</b> Amortecedor de feltro 20*20 / Filtro protector 20*20 / Filziger Dampfer 20*20 / Αποσβεστήρας από τσόχα 20*20 / Filca amortizators 20*20 / Amortizor din pãslã 20*20 / Vildist amortisaator 20*20	2

**Leg configuration depends on the bed model demonstrated as a sample at the store or website.**

**Moimentaço dos pés depende do modelo fornecido como exemplo no salão ou no site**

**El diseño de las patas depende del modelo de cama mostrado en la tienda o el sitio web.**

**Die Modifikation der Füße hängt vom Bettmodell, das als Muster im Möbelsalon oder auf der Webseite präsentiert wurde**

**Η τροποποίηση των ποδιών εξαρτάται από το μοντέλο του κρεβατιού που παρουσιάζεται ως δείγμα στο σαλόνι ή στον ιστότοπο**

**Kājiņu modifikācija ir atkarīga no gultas modeļa, kas salonā vai vietnē tiek parādīta kā paraugs**

**Modificarea picioarelor depinde de modelul de pat prezentat ca eşantion în salon sau pe site**

**Jalgade modifitiksioon sõltub näitusesaalis või kohapeal näidisenä esitatud voodi mudelist.**



### **Before Assembly:**

1. Check the appearance and completeness of items in pack! Claims for damage can only be made for articles with NO evidence of assembly.
2. Keep packs and instructions until assembly completed! If defects or missing parts are noted during assembly, the pack must be kept until the arrival of Seller's representative.
3. Check the quantity of hardware items against the list. The manufacturer retains the right to make construction changes in an item, replace hardware and fasteners with equivalent items that do not detract from their appearance, nor affect their functionality. In the case of missing parts or breakage, circle the number of the missing item and inform the store to receive a replacement.
4. Follow the assembly sequence in these instructions! Manufacturer's warranty obligations become void if instructions for assembly and use are not followed.
5. Install the bed on a level floor surface! On an uneven floor, the bed adjustment mechanisms may not work correctly or become deformed. Assemble bed with 2 people.
6. Assemble parts with care without sharp twists. Set parts stably on floor. Avoid dropping or banging!
7. Move furniture and its parts with only slight lifting. This helps to prevent distortions and breakage.
8. Be sure to lubricate the lifting mechanism during assembly according to the instructions! It allows you to avoid early appearance of creaking. Repeat lubrication; tighten loose bolts and nuts at least once every six months
9. New furniture can give off the original smell of the materials from which it is manufactured. The smell can last for three weeks after assembly. It is recommended to vacuum an item and ventilate the room to reduce the strength of the smell. One should repeat these steps 3-4 times per day.

### **Antes del montaje:**

1. ¡Compruebe el aspecto y la integridad de las piezas en el embalaje! Se aceptan reclamaciones por daños solo de los artículos SIN rastros de montaje.
2. ¡Conserve el embalaje y las instrucciones hasta terminar el montaje! Si durante el proceso de montaje se detecta algún defecto y falta de alguna pieza del artículo, debe conservar el embalaje hasta la llegada a su domicilio del representante de la empresa comercial.
3. Verifique la cantidad de accesorios según la lista. El fabricante se reserva el derecho de realizar cambios estructurales del artículo, reemplazar accesorios y piezas metálicas por otros similares que no afecten la apariencia y las propiedades funcionales del artículo. En caso de falta o rotura, marque el número de la pieza faltante e informe a la tienda para su cambio.
4. ¡Siga el procedimiento de montaje que se proporciona en este manual! Si no se sigue las instrucciones de montaje y uso, el fabricante no se responsabiliza de la garantía.
5. Para el montaje de la cama, ¡elijá una superficie plana! En una superficie no plana, es posible el mal funcionamiento del mecanismo de transformación de la cama, deformaciones del artículo.
6. El montaje de la cama debe ser realizada por dos personas. Mueva todas las piezas con cuidado, sin sacudidas, colóquelas sólidamente, evite las caídas y golpes!
7. Mueva el mueble y sus piezas levantando ligeramente. Esto permitirá evitar la deformación y roturas.
8. ¡Lubrique sin falta el mecanismo de elevación durante el ensamble, de acuerdo con las instrucciones! Esto evitará que surjan crujidos antes de tiempo. Repita la lubricación y apriete los tornillos y tuercas flojas al menos una vez cada seis meses.
9. El mueble nuevo puede emitir un olor natural de los materiales de fabricación. El olor puede persistir hasta por tres semanas desde el momento del montaje. Para reducir la intensidad del olor, se recomienda aspirar el artículo y ventilar la habitación. Estas acciones deben repetirse 3-4 veces al día.

### **Antes da montagem:**

1. Verifique o tipo e a integridade das peças da embalagem! Reclamação somente por defeitos de fabricação SEM vestígios de montagem.
2. Guarde a embalagem e o manual antes de terminar a montagem! Se identificar que produto está com defeito e incompleto durante a montagem, é necessário guardar a embalagem até a visita do representante comercial da empresa.
3. Verifique o número de peças de acessórios de acordo com a lista. O fabricante reserva-se o direito de fazer alterações estruturais no produto, substituir acessórios e peças por similares que não prejudiquem a aparência e não afetem as propriedades funcionais do produto. Em caso de falta ou dano, destaque o número da peça que falta e informe à loja para que seja feita a substituição.
4. Observe a sequência de montagem que está nas instruções! A não observância das instruções de montagem e de operação do fabricante retira as obrigações de garantia.
5. Escolha uma área plana para a instalação da cama! Com a curvatura do piso, podem ocorrer desvios na operação do mecanismo de transformação da cama, o que pode distorcer a forma do produto.
6. Não realize a montagem da cama sozinho(a). Mova todas as peças com cuidado, sem solavancos, coloque-as firmemente, evite quedas e batidas!
7. Para mover o móvel e suas peças, apenas levante-o um pouco. Isto evitará deformação e quebra.
8. De acordo com o manual na montagem precisa lubrificar um mecanismo de elevação necessariamente. Isso permitirá evitar o aparecimento de ruídos prematuros. Repita a lubrificação, aperte os parafusos e as porcas soltos pelo menos.
9. Móveis novos podem exalar o cheiro natural dos materiais dos quais são feitos. O cheiro pode persistir por três semanas após a montagem. Para reduzir a intensidade do cheiro, é recomendável aspirar o produto e ventilar a área. Isto deve ser feito 3-4 vezes ao dia.

## **Vor der Montage:**

1. Überprüfen Sie bitte das Aussehen und die Vollständigkeit der Bauelemente in der Verpackung! Reklamationen wegen einer Beschädigung der Bauelemente werden nur bei Produkten OHNE Montagespuren angenommen.
2. Bewahren Sie bitte die Verpackung und die Montierungsanweisungen bis Ende der Montage auf! Bei der Feststellung von Mangelwaren im Prozess der Montage und einer Unvollständigkeit des Produktes muss man die Verpackung bis zum Moment aufbewahren, wenn ein Vertreter des Handelsunternehmens zu Ihnen kommt.
3. Überprüfen Sie die Anzahl der Bauelemente und der Beschläge laut der Liste. Das Herstellerunternehmen behält sich das Recht vor, konstruktive Änderungen im Produkt einzutragen, Beschläge und Kleinteile gegen gleiche Elemente zu ersetzen, die das Aussehen nicht verschlechtern und die Funktionseigenschaften des Produktes nicht beeinflussen. Im Fall einer Unvollständigkeit oder eines Defektes, zeichnen Sie bitte die Nummer des abwesenden Bauelementes aus und teilen Sie davon dem Lieferanten für seinen Ersatz mit.
4. Halten Sie bitte die Ordnung der Montage ein, die in dieser Bedienungsanleitung angegeben ist! Wenn die Montierungsanweisungen und Bedienungsanweisungen nicht eingehalten werden, erlöschen die Garantieverpflichtungen des Herstellerunternehmens.
5. Wählen Sie eine flache Bodenfläche für die Montage des Bettes! Wenn Verformungen des Bodens vorliegen, sind Abweichungen in der Arbeit des Transformationsmechanismus des Bettes und Schiefstellungen der Form des Produktes möglich.
6. Führen Sie die Montage des Bettes zu zweit aus. Bewegen Sie alle Bauelemente vorsichtig, ruckfrei, legen Sie sie bitte trittsicher, vermeiden Sie, dass sie fallen und geschlagen werden!
7. Bewegen Sie das Möbel und seine Bauelemente nur wenig lüpfend. Das lässt Verformungen und Brüche vermeiden.
8. Schmieren Sie die reibenden Teile der Vorrichtung während der Montage, schrauben Sie gelöste Bolzen und Muttern nicht seltener als einmal im halben Jahr! Das lässt die Entstehung des frühzeitigen Knirschens vermeiden.
9. Das neue Möbel kann einen natürlichen Duft der Stoffe haben, wovon es hergestellt ist. Der Duft kann im Laufe von drei Wochen ab dem Moment der Montage bleiben. Es wird empfohlen, das Produkt mit dem Staubsauger zu reinigen und den Raum zu lüften, damit die Intensität des Duftes reduziert wird. Diese Handlungen muss man 3-4 Mal pro Tag ausführen.

## **Πριν από τη συναρμολόγηση:**

1. Ελέγξτε την εμφάνιση και την ακεραιότητα των ανταλλακτικών στη συσκευασία! Αξιώσεις για ζημιά μόνο σε προϊόντα ΧΩΡΙΣ ίχνη συναρμολόγησης.
2. Διατηρήστε τη συσκευασία και τις οδηγίες μέχρι το τέλος της συναρμολόγησης! Εάν κατά τη διαδικασία συναρμολόγησης εντοπιστεί ελαττωματικό και ελλιπές προϊόν, είναι απαραίτητο να διατηρήσετε τη συσκευασία μέχρι να έρθει εκπρόσωπος της εμπορικής εταιρείας σε σας.
3. Ελέγξτε τον αριθμό των εξαρτημάτων υλικού σύμφωνα με τη λίστα. Ο κατασκευαστής διατηρεί το δικαίωμα να κάνει αλλαγές στο σχεδιασμό του προϊόντος, να αντικαταστήσει εξαρτήματα και εξοπλισμό με παρόμοια που δεν επιδεινώνουν την εμφάνιση και δεν επηρεάζουν τις λειτουργικές ιδιότητες του προϊόντος. Σε περίπτωση ατελούς ή βλάβης, κάντε κύκλο στον αριθμό του ελλείποντος τμήματος και ενημερώστε το κατάστημα για την αντικατάστασή του.
4. Ακολουθήστε τη σειρά συναρμολόγησης που παρέχεται σε αυτό το εγχειρίδιο! Η μη τήρηση των οδηγιών συναρμολόγησης και λειτουργίας ακυρώνει την εγγύηση του κατασκευαστή.
5. Για να εγκαταστήσετε το κρεβάτι, επιλέξτε μια επίπεδη επιφάνεια του δαπέδου! Με καμπυλόττες δαπέδου, είναι πιθανές αποκλίσεις στη λειτουργία του μηχανισμού μετασχηματισμού κλίνης και παραμορφώσεων σχήματος προϊόντος. Συναρμολογήστε το κρεβάτι μαζί.
6. Μετακινήστε προσεκτικά όλα τα υλικά, χωρίς να χτυπήσετε, τοποθετήστε τα με ασφάλεια, αποφύγετε την πτώση και την πρόσκρουση!
7. Μετακινήστε τα έπιπλα και τα μέρη του λίγο ανεβαίνοντας τα. Αυτό θα εξαλείψει τις παραμορφώσεις και τις βλάβες. Φροντίστε να λιπάνετε το μηχανισμό ανύψωσης κατά τη συναρμολόγηση σύμφωνα με τις οδηγίες! Αυτό θα αποφύγει το πρόωρο τσίμπημα.
8. Φροντίστε να λιπάνετε το μηχανισμό ανύψωσης κατά τη συναρμολόγηση σύμφωνα με τις οδηγίες! Αυτό θα αποφύγει το πρόωρο τσίμπημα. Λιπάνετε εκ νέου, σφίξτε τα χαλαρά μπουλόνια και τα παξιμάδια τουλάχιστον μία φορά κάθε έξι μήνες.
9. Τα νέα έπιπλα μπορεί να εκπέμπουν μια φυσική μυρωδιά υλικών από τα οποία είναι κατασκευασμένα. Η μυρωδιά μπορεί να διαρκέσει έως και τρεις εβδομάδες από την ημερομηνία συναρμολόγησης. Για να μειώσετε την ένταση της οσμής, συνιστάται να καθαρίσετε με ηλεκτρική σκούπα το προϊόν και να αερίσετε το δωμάτιο. Αυτά τα βήματα πρέπει να επαναλαμβάνονται 3-4 φορές την ημέρα.

## **Pirms montāžas darbiem:**

1. Pārbaudiet detaļu izskatu un pilnību iepakojumā! Prasības par to bojājumiem tikai produktiem BEZ montāžas darbu pēdām.
2. Saglabājiet iepakojumu un instrukciju līdz montāžas darbu beigām! Ja montāžas procesā tiek atklāts produkta defekts un nepilnība, Jums ir jāsaņem iesaņojums, līdz tirdzniecības uzņēmuma pārstāvis atbrauks pie Jums.
3. Pārbaudiet piederumu skaitu atbilstoši sarakstam. Ražotājs patur tiesības veikt izstrādājuma konstruktīvās izmaiņas, nomainīt piederumus un metālizstrādājumus ar analogiem, kuri nepasliktina izskatu un neietekmē produkta funkcionālās īpašības. Nepilnības vai bojājumu gadījumā apvelciet trūkstošās daļas numuru un informējiet veikalu par tās nomaiņu.
4. Izpildiet šajā instrukcijā norādīto montāžas kārtību! Montāžas un lietošanas instrukcijas neievērošana anulē ražotāja garantijas atbildību.
5. Lai uzstādītu gultu, izvēlieties līdzenu grīdas virsmu! Pie grīdas izliekumiem ir iespējamas novirzes gultas pārveidošanas mehānisma

darbībā, izstrādājuma formas deformācijas. Gultas montāžas darbus veiciet divatā.

6. Pārvietojiet visas detaļas uzmanīgi, bez raustīšanās, novietojiet tās droši, izvairieties no viņu krišanas un triecieniem! Pārvietojiet mēbeles un to daļas, tikai nedaudz paceļot. Tas novērsīs deformācijas un lūzumus.

7. Montāžas laikā noteikti ieeļļojiet pacēlāja mehānismu saskaņā ar instrukcijām! Tas ļaus izvairīties no priekšlaicīgas čīkstēšanas. Atkārtoti ieeļļojiet, pievelciet vaļīgas skrūves un uzgriežņus vismaz reizi sešos mēnešos.

8. Montāžas laikā noteikti ieeļļojiet pacēlāja mehānismu saskaņā ar instrukcijām! Tas ļaus izvairīties no priekšlaicīgas čīkstēšanas. Atkārtoti ieeļļojiet, pievelciet vaļīgas skrūves un uzgriežņus vismaz reizi sešos mēnešos.

9. Jaunas mēbeles var izdalīt dabisku smaržu no materiāliem, no kuriem tās izgatavotas. Smarža var ilgt līdz trim nedēļām no montāžas datuma. Lai samazinātu smakas intensitāti, ieteicams produktu nosūkt ar putekļu sūcēju un izvēdināt telpu. Šīs darbības jāatkārto 3-4 reizes dienā.



### **Înainte de asamblare:**

1. Verificați aspectul și integritatea detaliilor din pachet! Cererile pentru daunele lor sunt acceptate numai pentru produse FĂRĂ urme de asamblare.
2. Păstrați ambalajul și instrucțiunile până la sfârșitul asamblării! La detectarea defectelor în procesul de asamblare și dacă produsul este incomplet, este necesar să păstrați ambalajul până când reprezentantul companiei comerciale vă vizitează.
3. Verificați numărul de detalii și accesorii conform listei. Producătorul își rezervă dreptul de a face modificări constructive ale produsului, de a înlocui fittingurile și hardware-ul cu altele similare, care nu degradează aspectul și nu afectează proprietățile funcționale ale produsului. Dacă există o lipsă sau o defecțiune, încercați numărul detalii lipsă și informați magazinul să o înlocuiască.
4. Urmați procedura de asamblare dată în această instrucțiune! În caz de nerespectare a instrucțiunilor de asamblare și utilizare, obligațiile de garanție de la producător sunt eliminate.
5. Pentru a instala patul, alegeți o zonă plată a podelei! În cazul curbării podelei, abaterile sunt posibile în funcționarea mecanismului de transformare a patului și distorsiuni ale formei produsului.
6. Se recomandă ca două persoane să efectueze asamblarea patului. Mutați cu atenție toate detaliile, fără smucituri, le puneți stabil, evitați căderi și lovituri lor!
7. Mutați mobilierul și detaliile acestuia, ridicând doar ușor. Aceasta va elimina deformările și defalcări.
8. Asigurați-vă că lubrifiați mecanismul de ridicare în timpul asamblării, conform instrucțiunilor! Aceasta va ajuta la evitarea apariției scârțâitului prematur. Repetați lubrifierea, strângeți șuruburile și piulițele slăbite cel puțin o dată la șase luni.
9. Mobilierul nou poate avea un miros natural al materialelor din care este fabricat. Mirosul poate persista timp de trei săptămâni de la momentul asamblării. Pentru a reduce intensitatea mirosului, se recomandă aerisirea produsului și ventilarea camerei. Aceste acțiuni trebuie repetate de 3-4 ori pe zi.

### **Enne kokkupanemist:**

1. Kontrollige pakendis olevate detailide välimust ja terviklikkust! Nende kahjuga seotud pretensioone aktsepteeritakse ainult ILMA kokkupanemisjälgedeta toodete puhul.
2. Säilitage pakend ja juhised kuni kokkupaneku lõpuni! Diivani kokkupanemisel toote praagi ja mittekomplektsuse tuvastamisel pakend on vajalik säilitada kuni kaubandusettevõtte esindaja teie juurde tulekuni.
3. Kontrollige detailide ja furnituuri arvu vastavalt loendile. Tootja jätab endale õiguse teha tootes konstruktsioonilisi muudatusi, vahetada furnituur ja peenraud sarnaste vastu, mis ei halvenda välimust ega mõjuta toote funktsionaalseid omadusi. Puuduse või rikke korral, märgistage puuduva detaili number ümber ja võtke asendamiseks ühendust kauplusega.
4. Järgige selles juhendis antud kokkupanemise järjestust! Kokkupanemis- ja kasutusjuhendi mittejärgimisel, kaotab tootja garantii kehtivuse.
5. Diivani paigaldamiseks valige tasane põrandapind! Põranda kumerusel võib esineda kõrvalekaldeid diivanvoodi/tugitoolvoodi transformatsiooni mehhanismi töös, toote kuju moonutusi.
6. Pange diivan kokku kahekesi. Liigutage kõiki detaile ettevaatlikult, ilma tõmblusteta, asetage need kindlalt, vältige nende kukkumist ja löömist!
7. Liigutage mööblit ja selle detaile, tõstes vaid veidi. See hoiab ära deformatsiooni ja purunemise.
8. Määrige kindlasti tõstemehhanismi kokkupanemise ajal vastavalt juhendile! See hoiab ära enneaegse krigisemise. Korra määrimist, pingutage silmnähtavalt lahtised poldid ja mutrid vähemalt kord kuue kuu tagant.
9. Uus mööbel võib materjalidest, millest see on valmistatud, eraldada loomulikku lõhna. Lõhn võib püsida kolme nädala jooksul alates kokkupaneku hetkest. Lõhna intensiivsuse vähendamiseks on soovitatav toode tolmuimejaga imeda ja ruumi tuulutada. Neid toiminguid tuleb korrata 3-4 korda päevas.

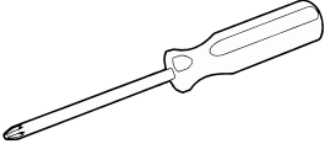
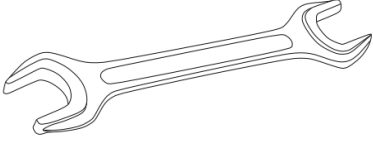
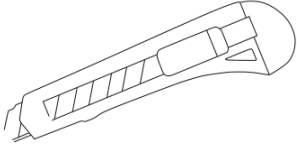
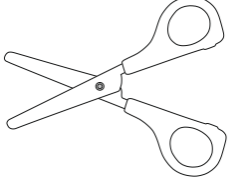
Items required for assembly is listed below/ Para el ensamble usted necesitará/ Para montagem, você precisará/ Für die Montage brauchen Sie Folgendes/Για την συναρμολόγηση θα χρειαστείτε/ Montāžas darbiem nepieciešams/ Pentru asamblarea veți avea nevoie de/ Kokkupanemiseks vajate:

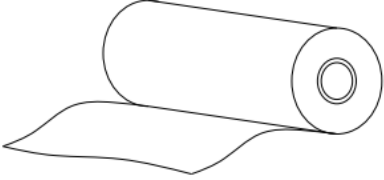
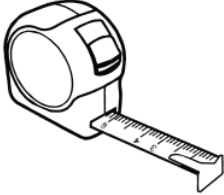
	<p><b>Screwdriver /</b>          Chave de fenda estrela / Destornillador de Estrella /          Kreuzschraubenzieh / Κατσαβίδι εγκάρσιας κεφαλής /          Skrūvgriezis krusta / Şurubelniță cu cap /          Ristpeaga kruvikeeraja</p>
	<p><b>Open-end Wrench №13 /</b>          Chave de boca №13 / Llave fija №13 /          Offener Schraubenschlüssel №13 /          Κλειδί ανοικτού τύπου αρ. 13 /          Tapatslēga Nr. 13 / Cheie deschisă nr. 13 / Mutrivõti nr 13</p>
	<p><b>Boxcutter /</b>          Estilete / Cuchillo de papelería /          Büromesser / Μαχάιρι / χαρτικών /          Kancelejas Nazis / Cuțit de papetărie /          Kirjatarvete nuga</p>
	<p><b>Scissors /</b>          Tijeras / Tesoura /          Schere / Ψαλίδια /          Šķēres / Foarfece / Käärid</p>
	<p><b>Machine oil/lubricant e.g. WD-40/silicone spray /</b>  <b>Aceite de instrumentos/grasa del tipo WD-40/Spray de silicona /</b>          Óleo de máquina/graxa tipo WD-40/spray de silicone /          Maschinenöl/Schmierstoff des Typen WD-40/Silikonspraystoff /          Λάδι μηχανής/σπρέι γράσου WD-40/τύπου σιλικόνης /          Mašīnu eļļa/WD-40 tipa smērviela/silikona aerosols /          Ulei de motor/spray tehnic lubrifiant tip WD-40/spray siliconic          Masinaõli/WD-40 määrdeaine/Silikoonmääre spreii</p>
	<p><b>Paper Towel /</b>          Toalha de papel / Papel absorbent /          Papierhandtuch / Χαρτοπετσέτα/          Papīra dvielis / Prosop hârtie / Paberrätik</p>
	<p><b>Tape Measure /</b>          Fita métrica / Cinta métrica /          Messband / Ρουλέτα /          Rulete / Ruletă / Mõõdulint</p>

1)

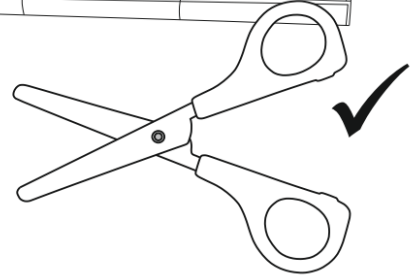
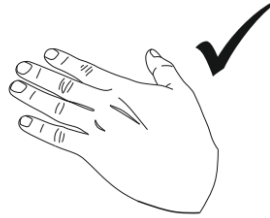
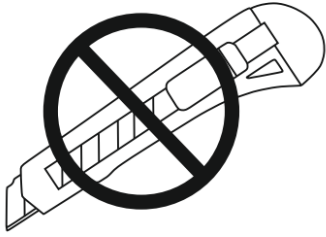
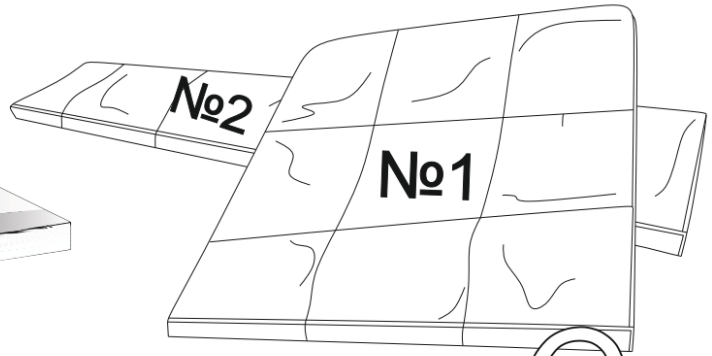

2)

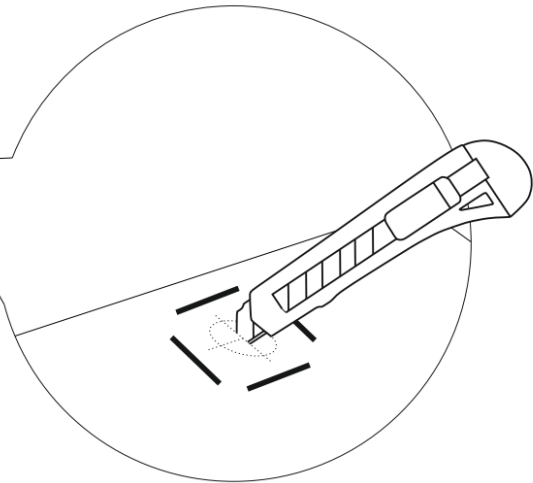
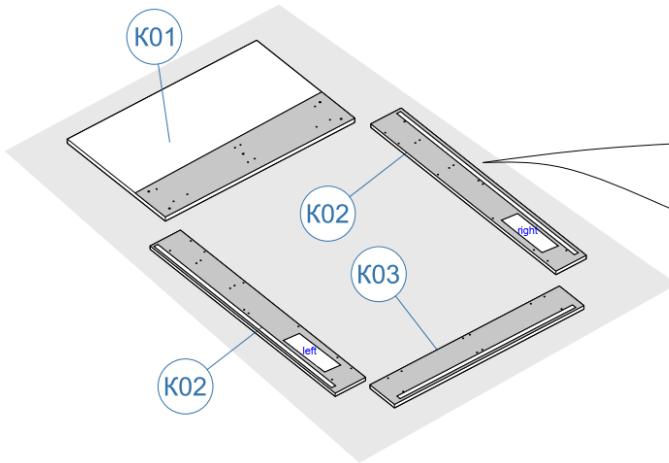

3)

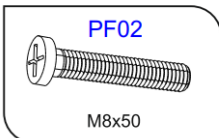
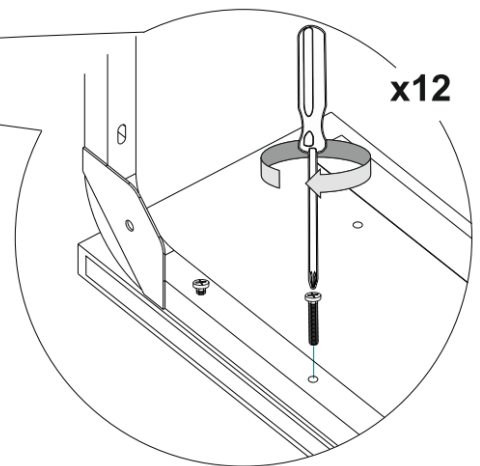
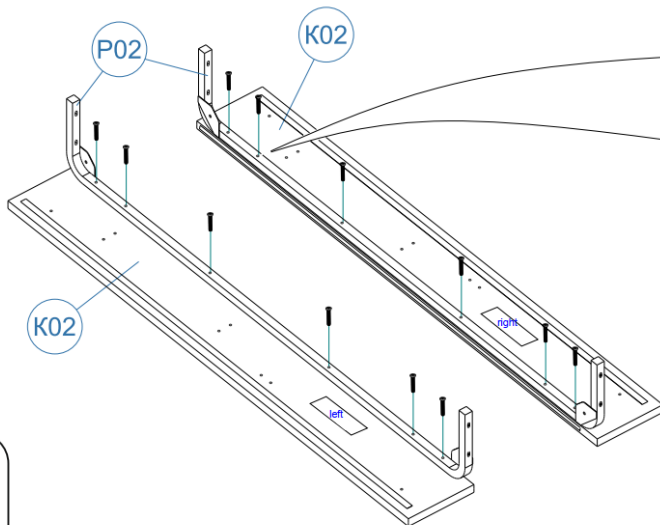



4)

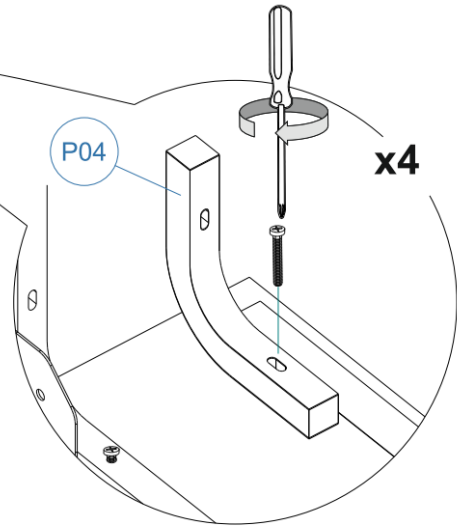
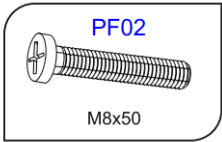
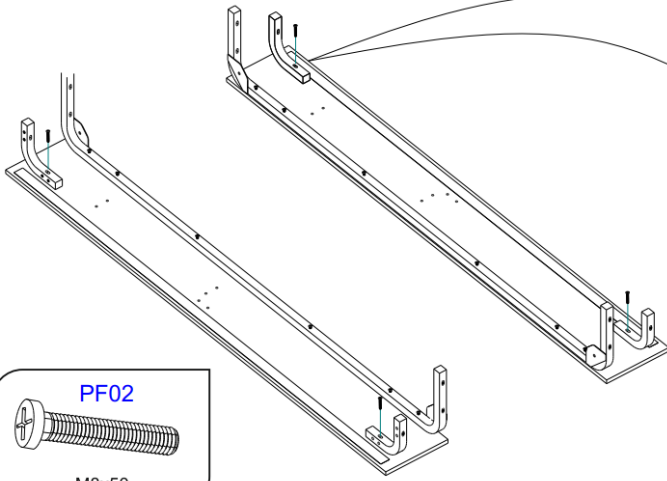

5)

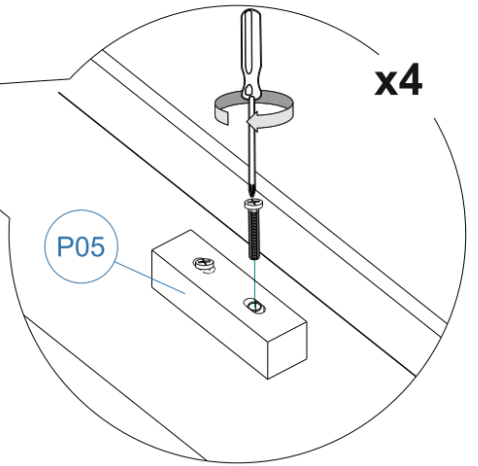
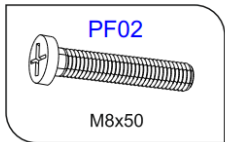
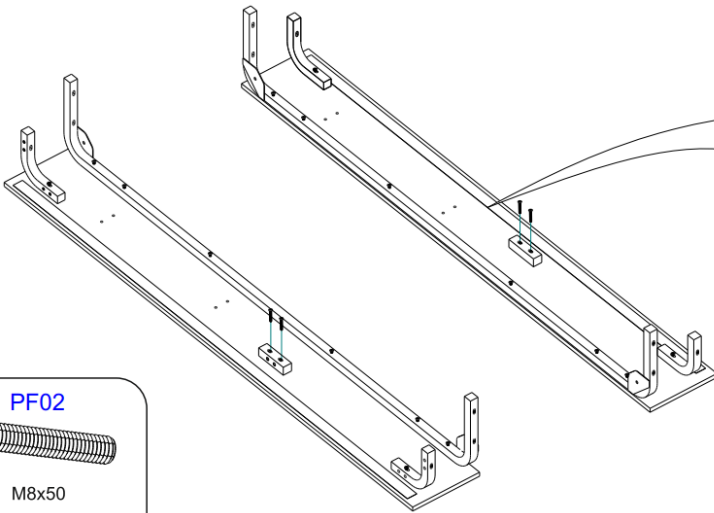

6)

Leg Parts No.1

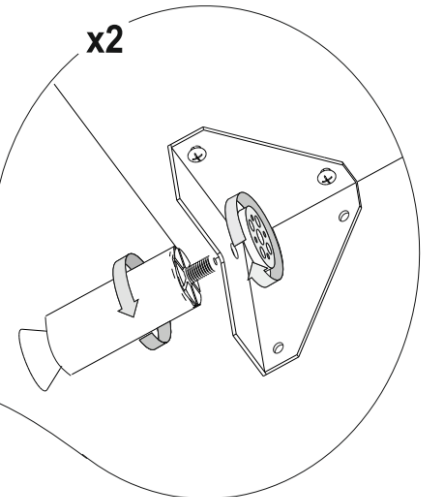
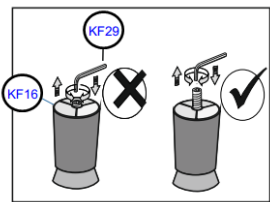
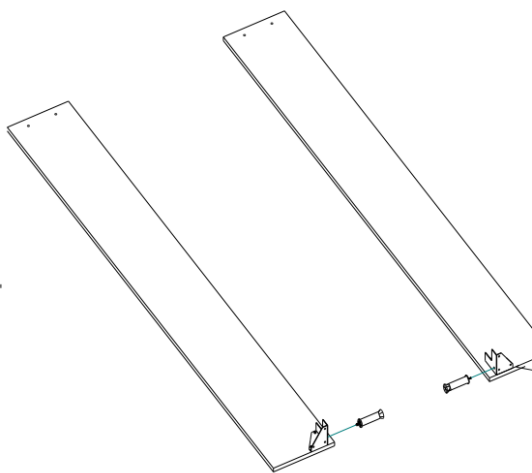

7)

Leg Parts No.2

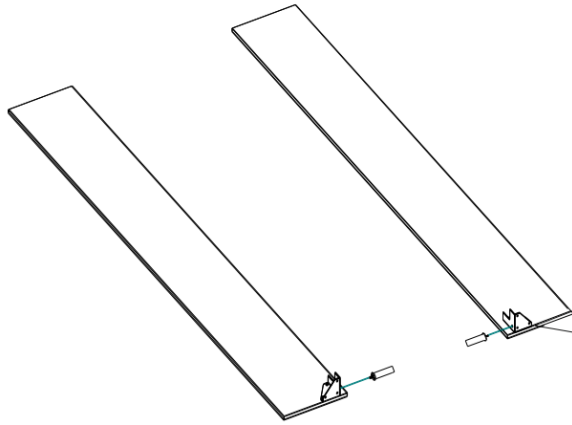
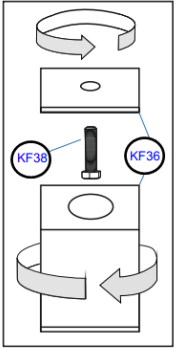

x2

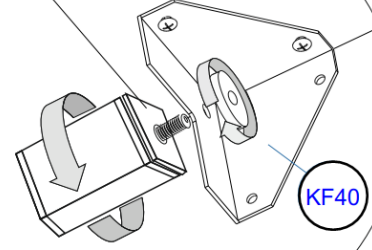

8)

Leg Parts No.3

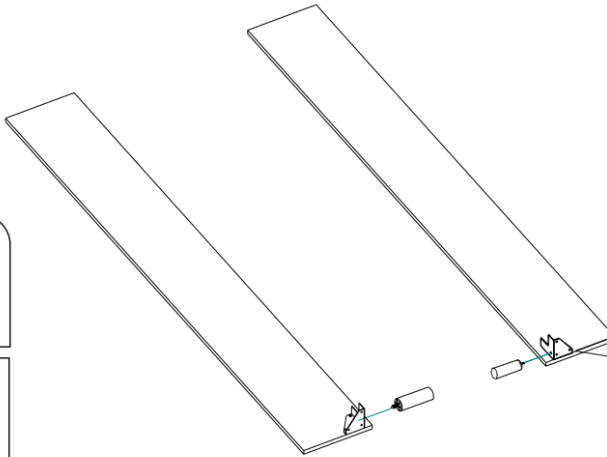
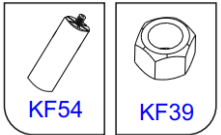
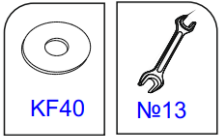

x2

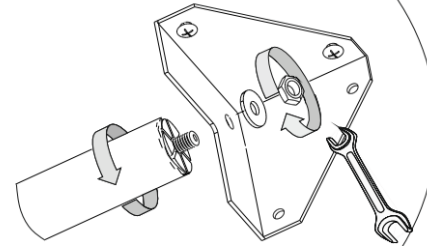

9)

Leg Parts No.4

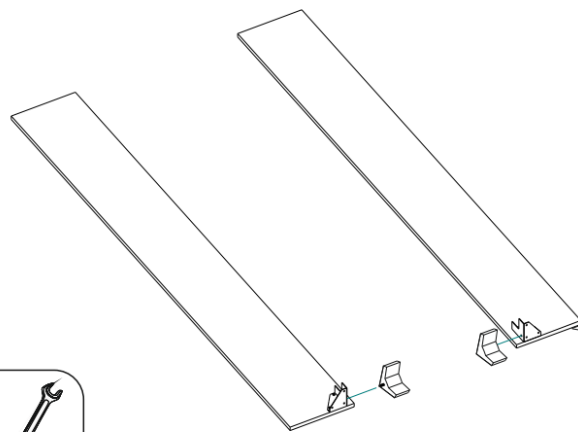
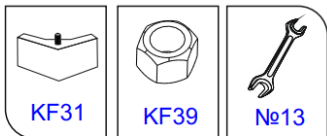
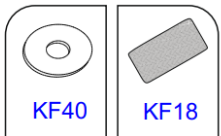
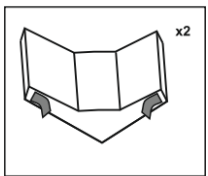

x2

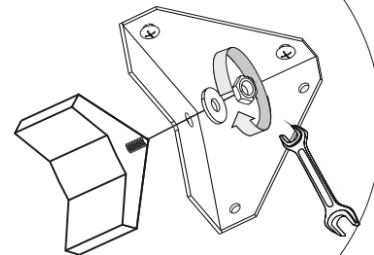

10)

Leg Parts No.5

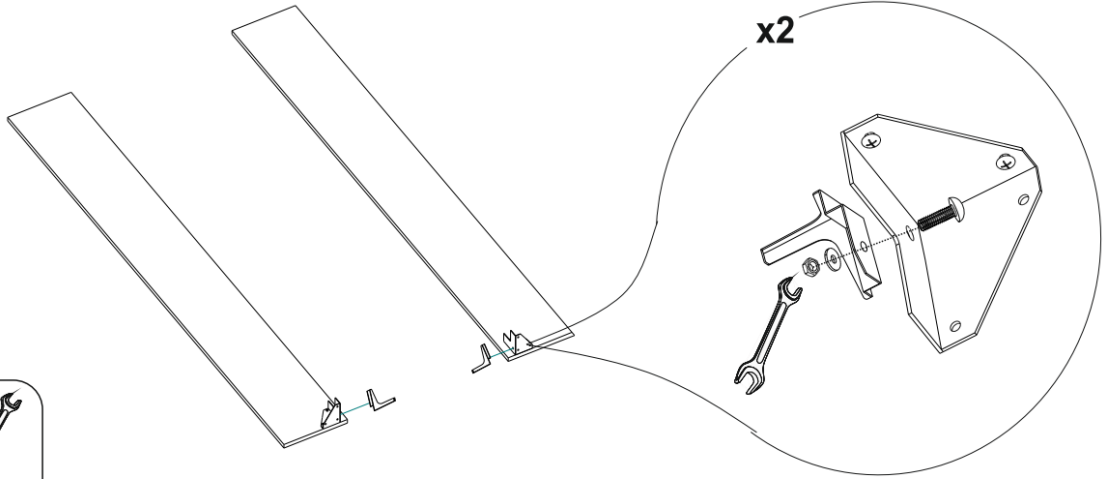
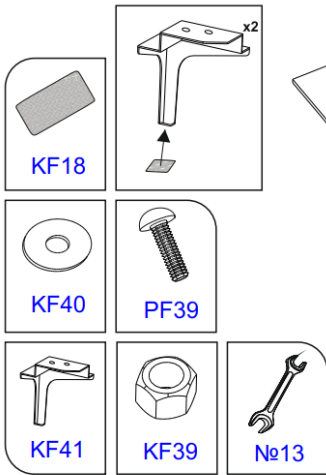

11)

Leg Parts No.6

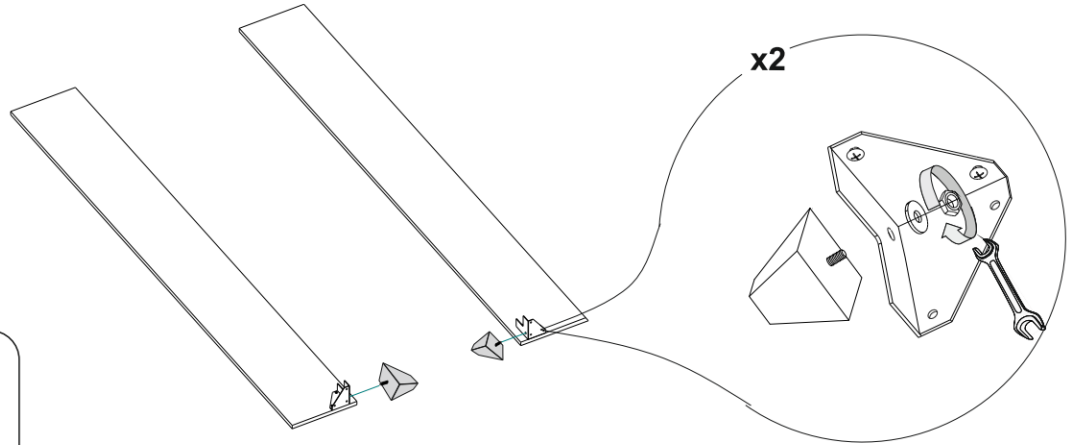
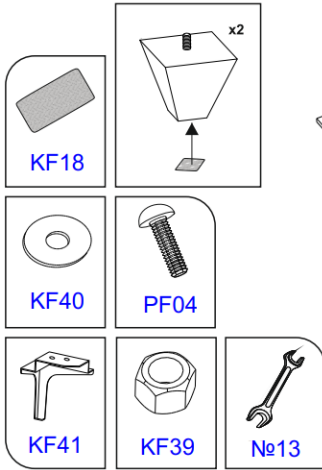

12)

Leg Parts No.7

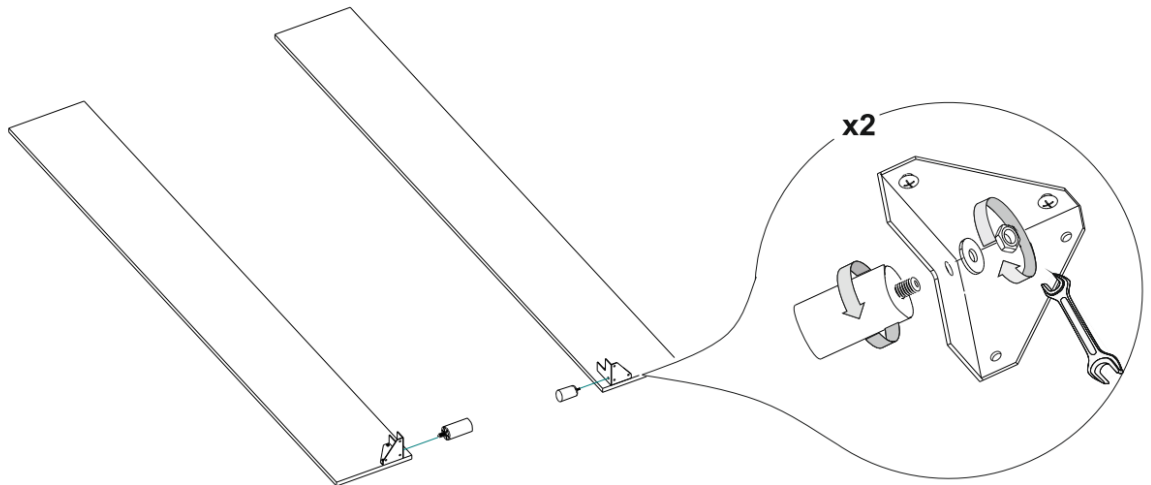

13)

Leg Parts No.8

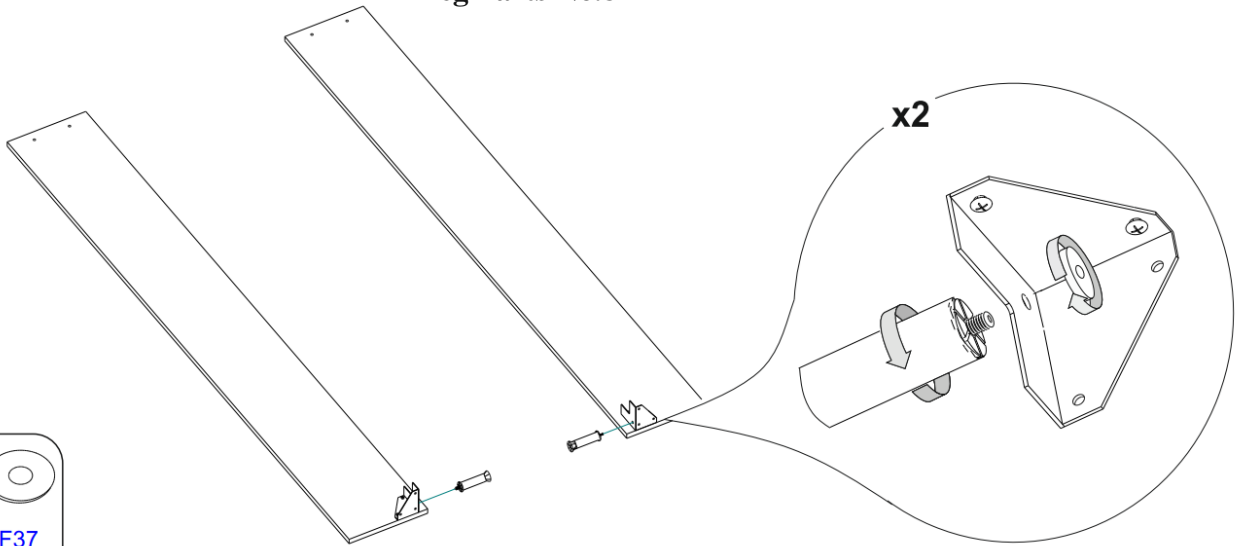
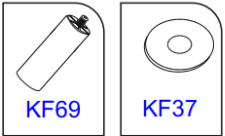

14)

Leg Parts No.9

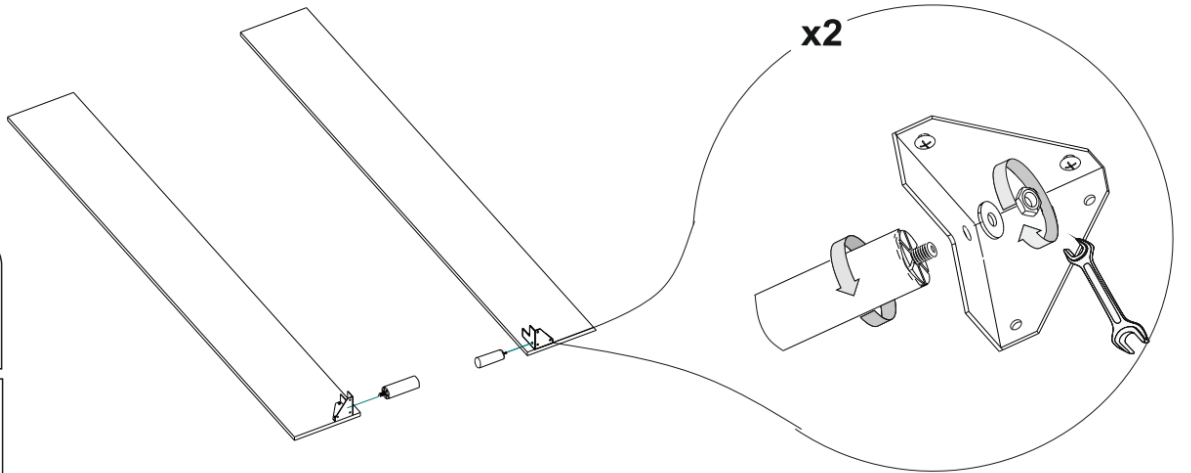

15)

Leg Parts No.10

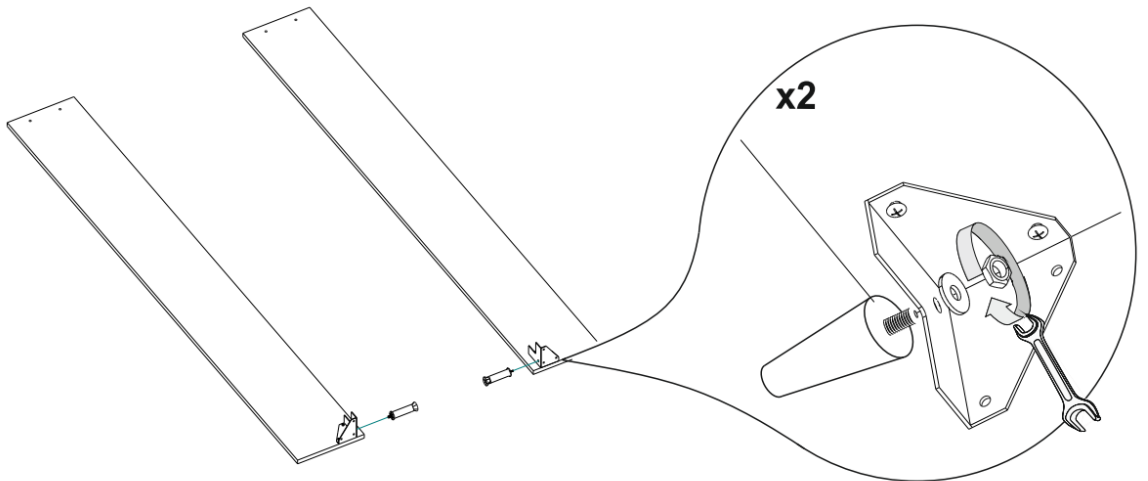
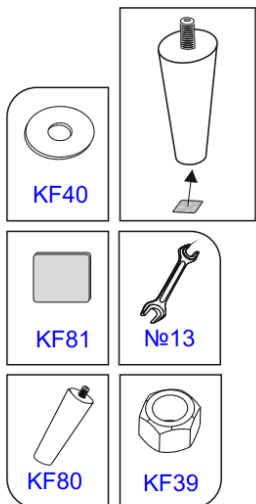

16)

Leg Parts No.11

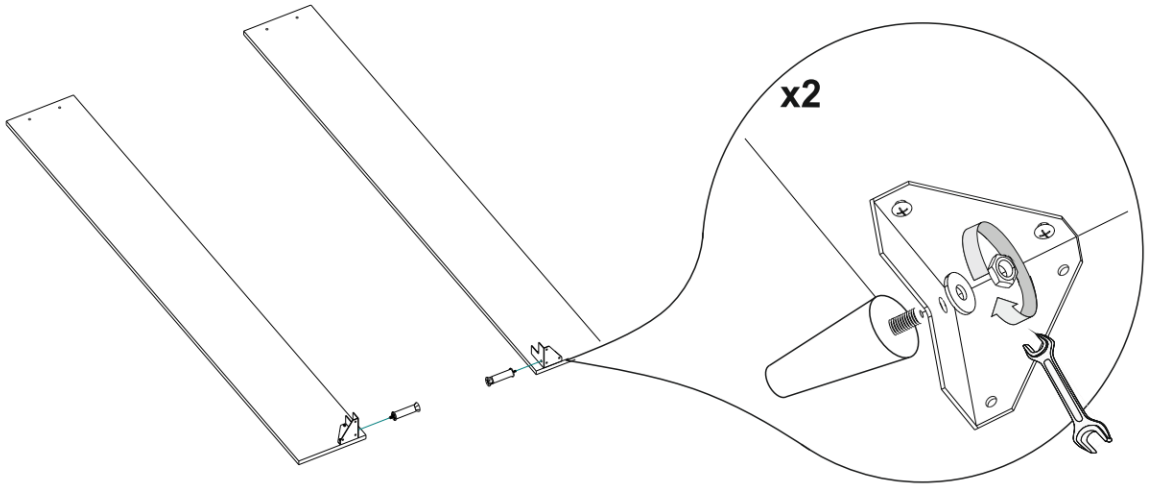

17)

Leg Parts No.12

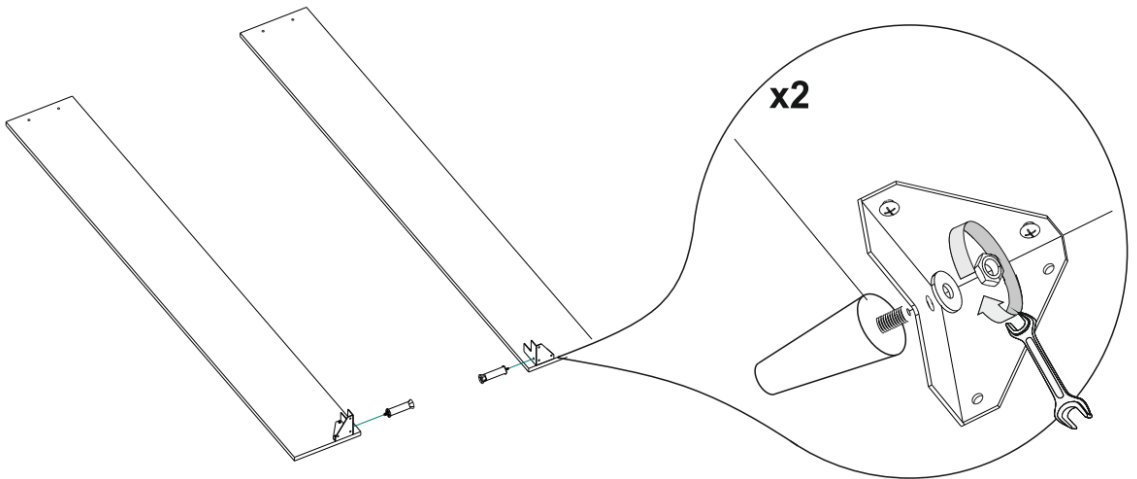
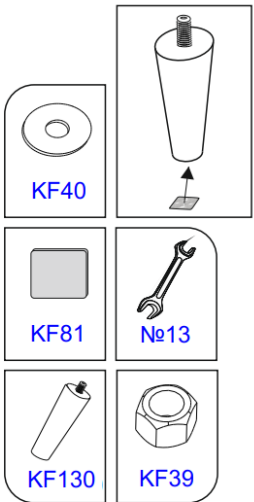

18)

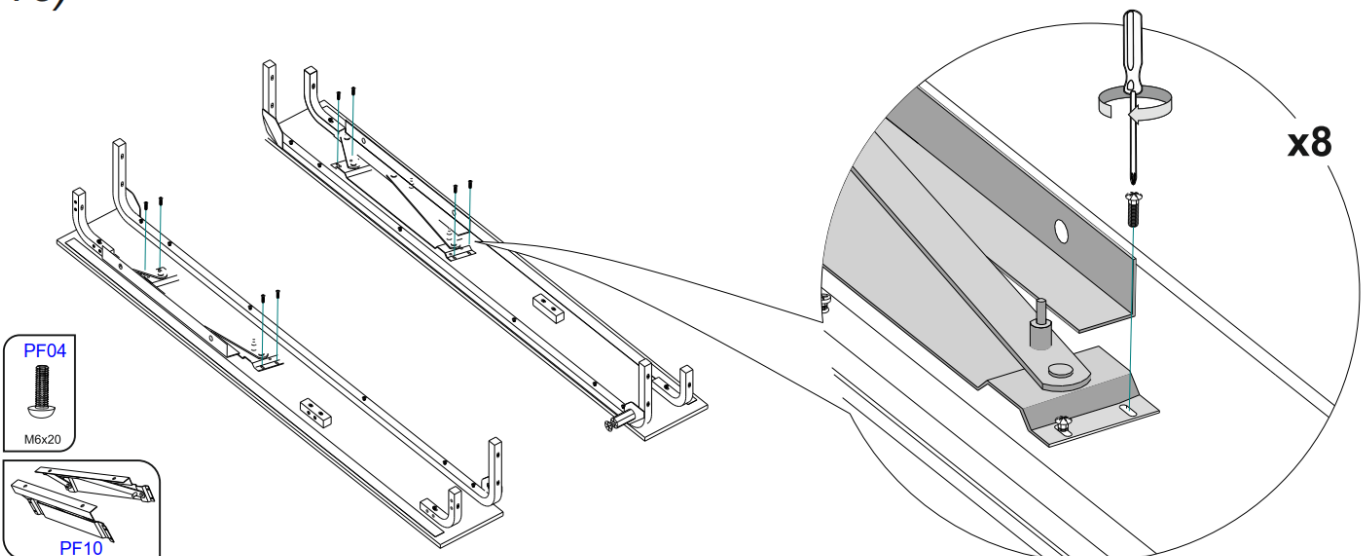

19)

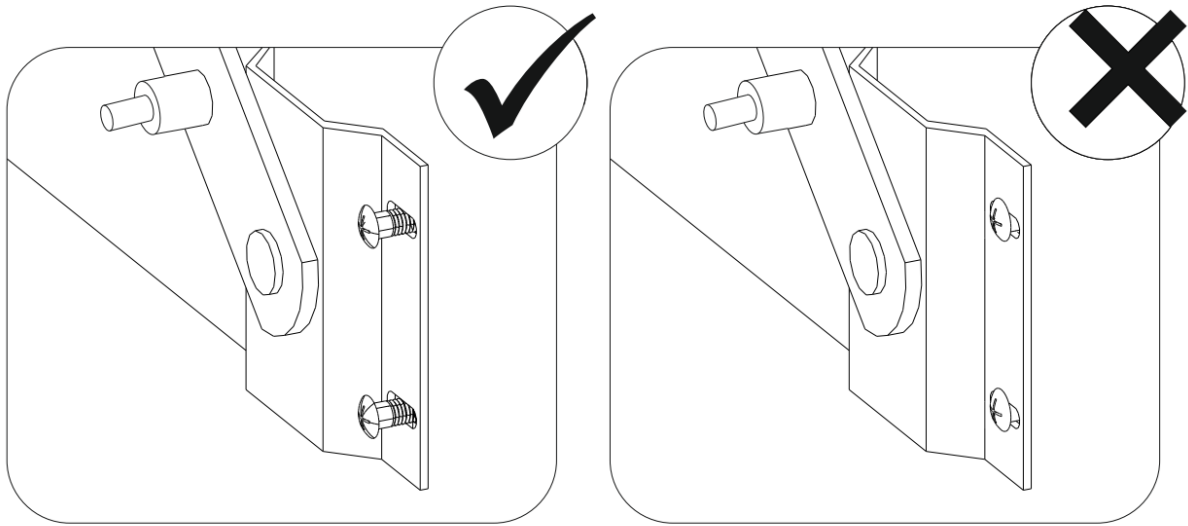

20)

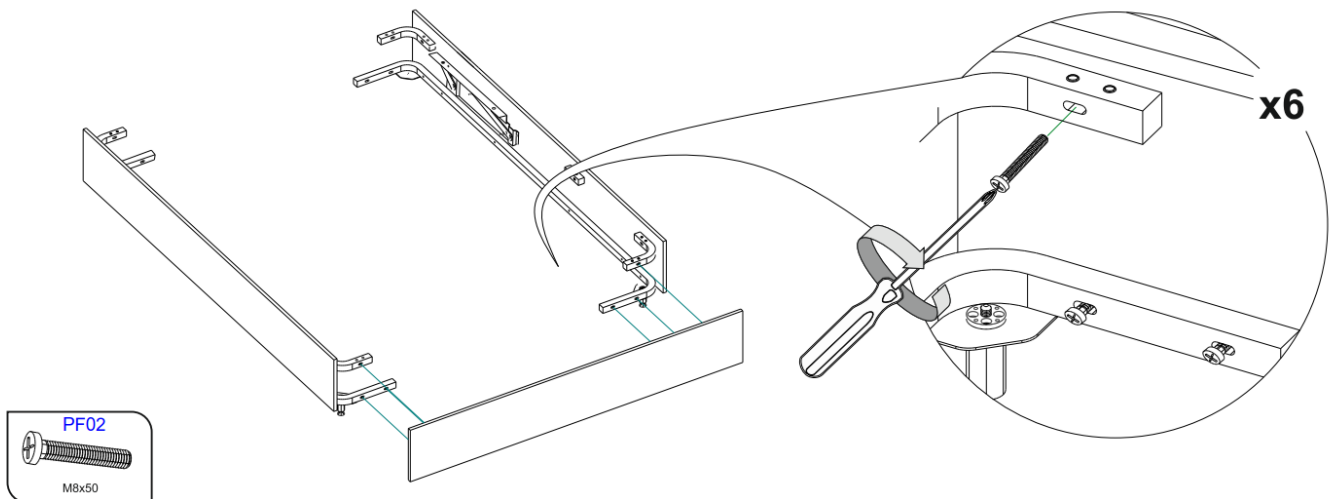

21)

**Installing the cover on the side-bars before attaching the headboard is only for beds Naomi, Emma, Rosalie, Merelin Premier**

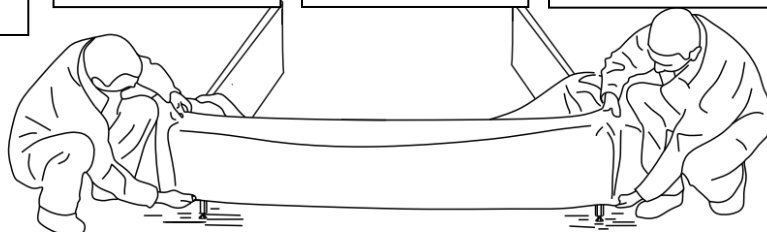
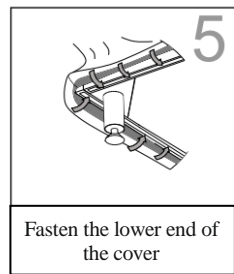
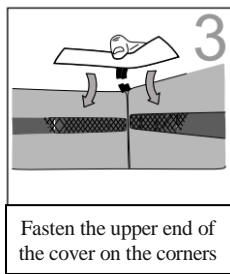
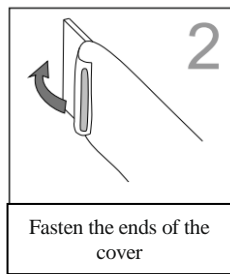
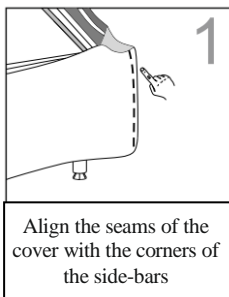

22)

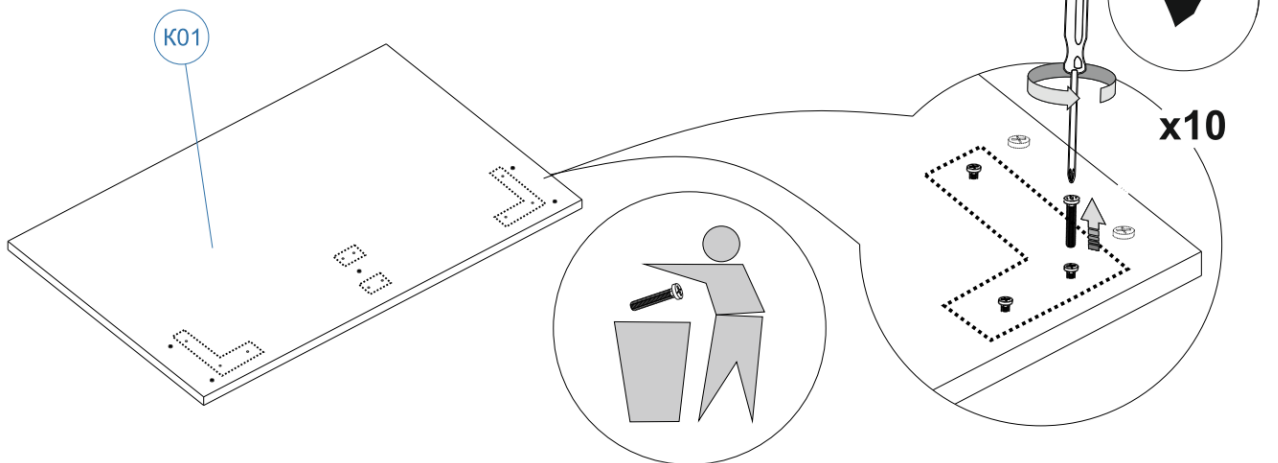

**Do not unscrew the edge row of screws (if applicable)!**

Não desaperte os parafusos da fila exterior (se existirem)!

¡No desatornille los tornillos de la fila exterior (si los hay)!

Die äußere Reihe der Schrauben nicht ausschrauben (wenn sie vorhanden sind)!

Μην ξεβιδώσετε την εξωτερική γραμμή βιδών (εάν υπάρχει)!

Neskrūvējiet ārējo skrūvju rindu (ja tāda ir)!

Nu deșurubați rândul exterior al șuruburilor (dacă există)!

Ärge keerake lahti viimast kruvide rida (kui on olemas)!

23)

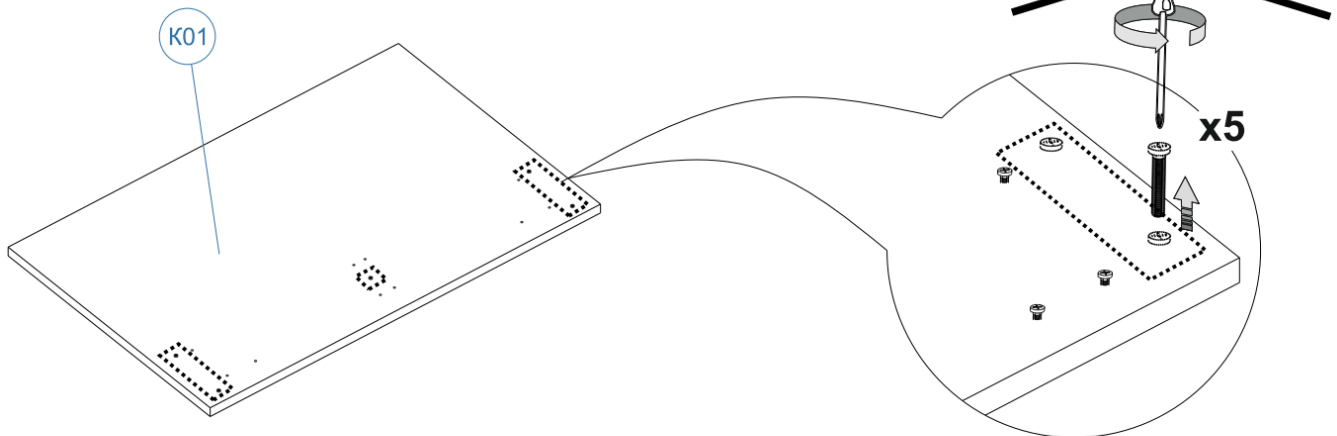

24)

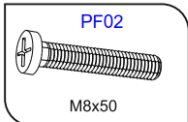
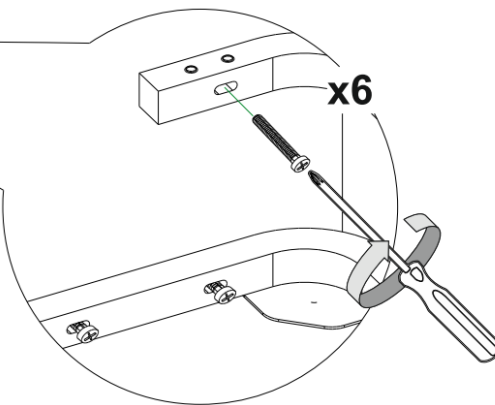
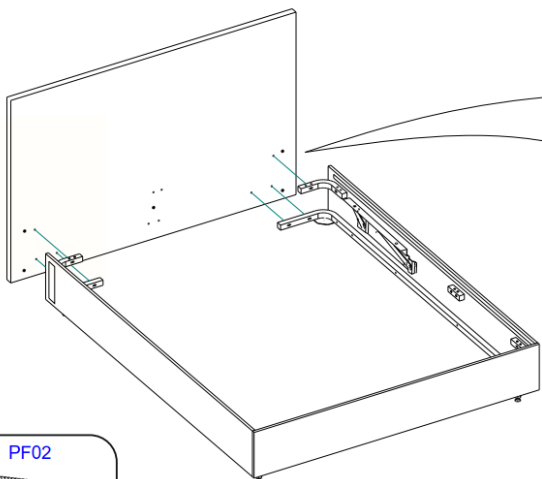

25)

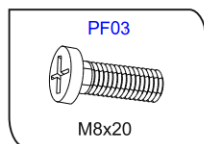
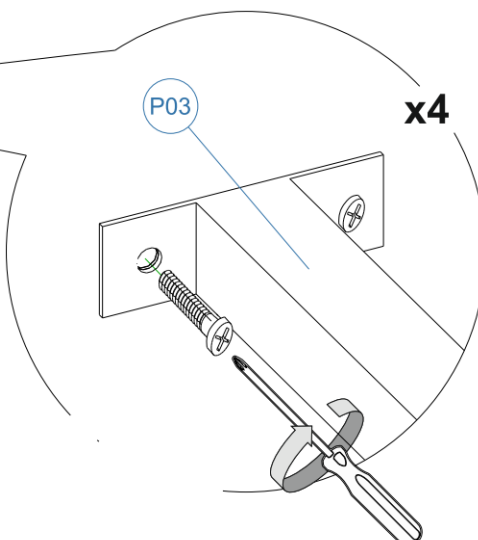
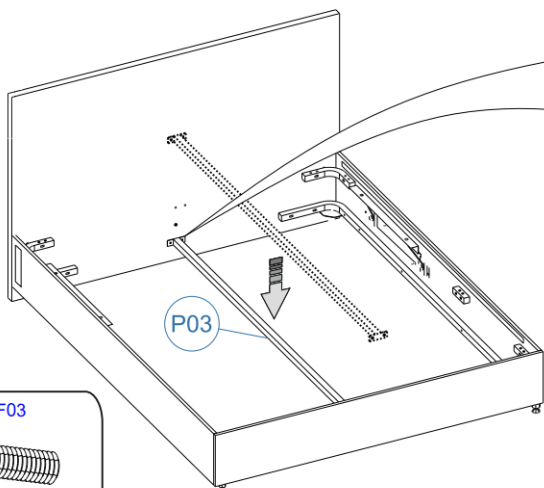

26)

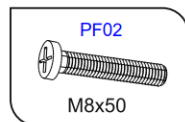
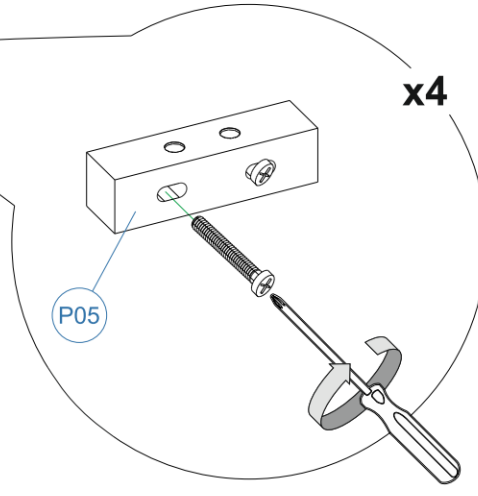
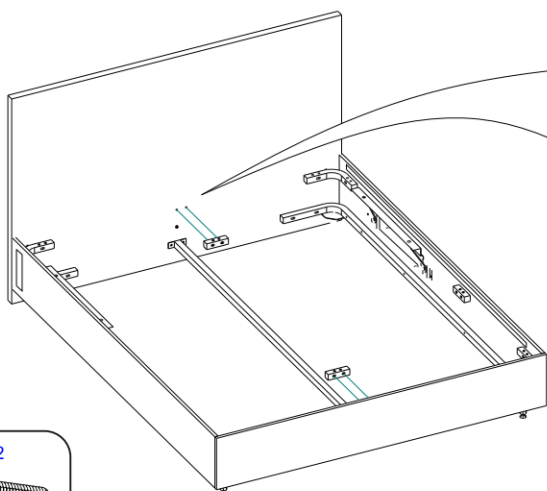



27)

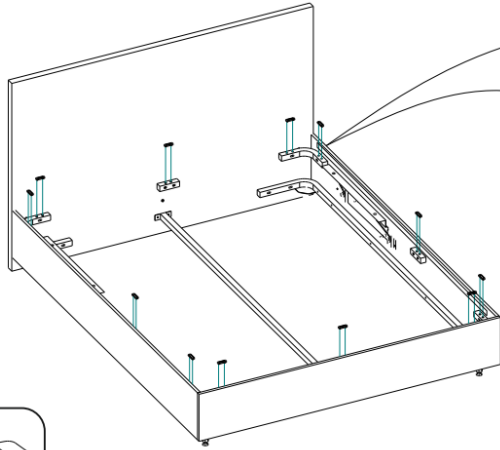

x12

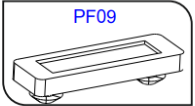

PF09

28)

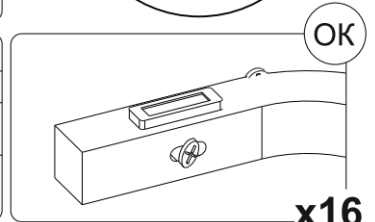
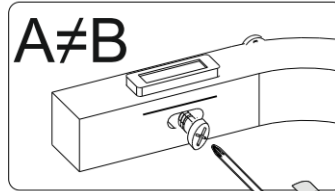
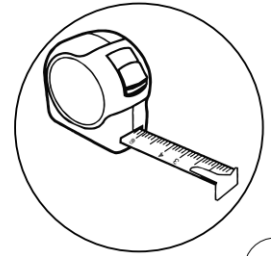
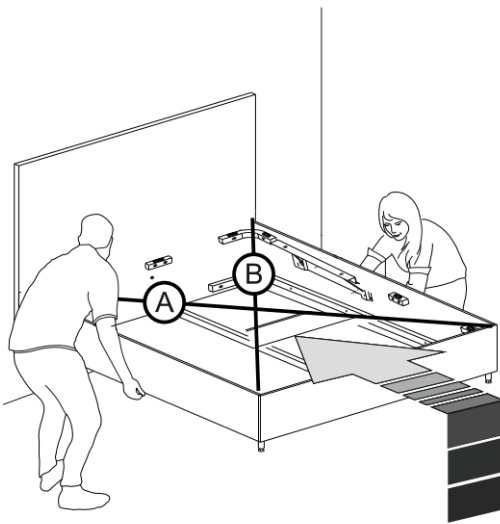

x16

29)

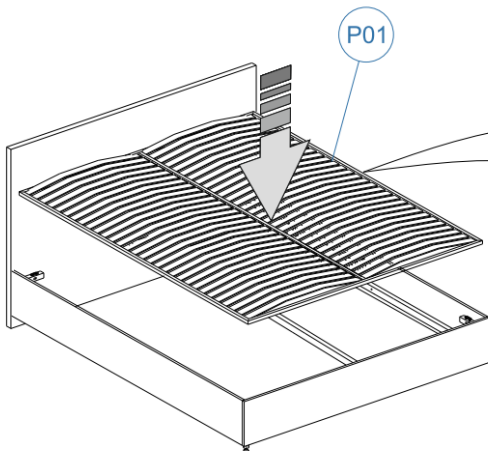

P01

x4

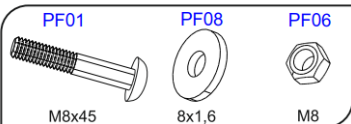

PF01

PF08

PF06

M8x45

8x1.6

M8

№13

30)

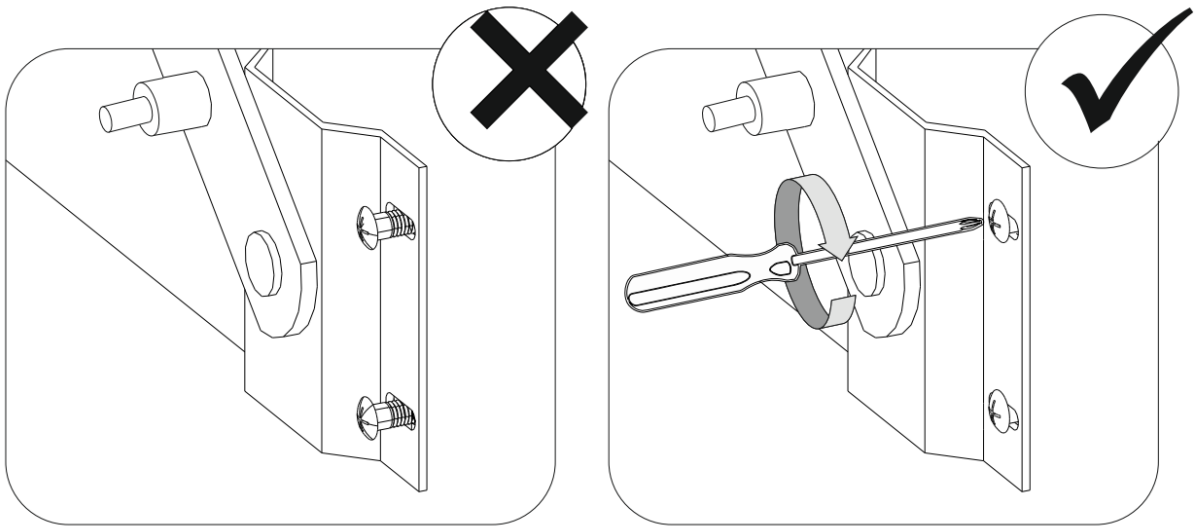

**The parts and assembly procedure may vary depending on the configuration of the lifting mechanism, please see the base certificate,**

O kit e procedimento da montagem pode variar conforme modificação do mecanismo de elevação ver passaporte.

Los componentes y la secuencia de montaje pueden variar en función del modelo de mecanismo de elevación. Consulte el documento de información del somier.

Die Komponenten und das montageverfahren können je nach Konfiguration des hebemechanismus, siehe Basiszertifikat.

Το πλήρες σετ και σειρά συναρμολόγησης μπορεί να ποικίλει ανάλογα με την τροποποίηση του μηχανισμού ανύψωσης. Βλ. το διαβατήριο της βάσης  
Komplektācija un montāžas secība var atšķirties atkarībā no pacelšanas mehānisma modifikācijas. Skatiet pamatnes pasi

Configurația și procedura de asamblare depinde de modificarea mecanismului de ridicare. A se vedea pașaportul bazei patului

Komplektsus ja kokkupaneku järjestus võivad olenevalt tõstemehhanismi modifikatsioonist erineda. Vt aluse pass

31)

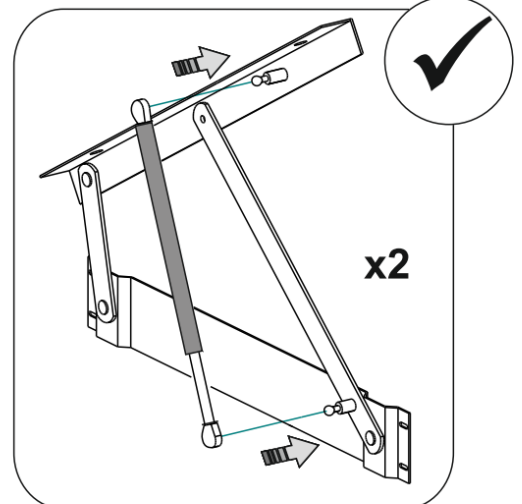
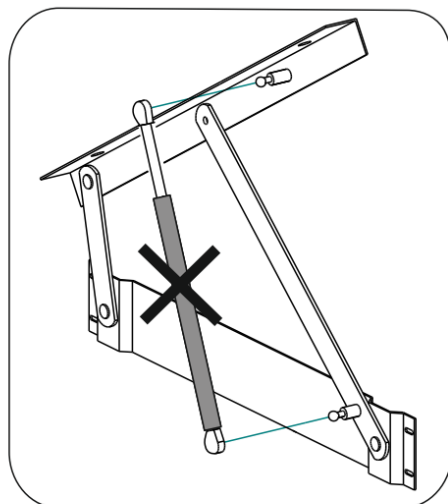
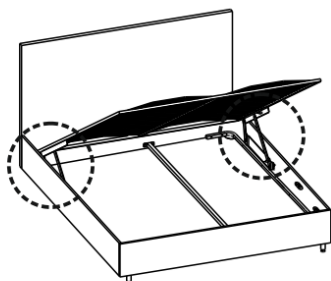
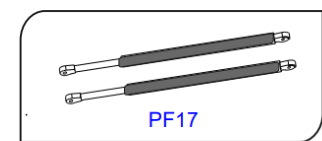

32)

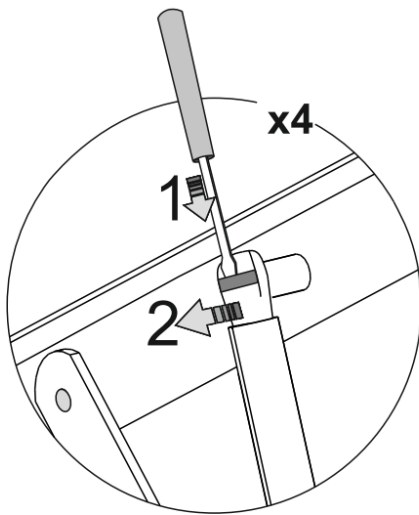

The configuration and assembly sequence may vary depending on the modification of the lifting mechanism. See passport of the base.

To remove gas-lift unit you should:

- 1) slide a flat screwdriver under the metal mounting bracket;
- 2) lift the bracket up;
- 3) remove the gas-lift unit mount from the stud;
- 4) repeat on the backside.

O conjunto e a sequência de montagem podem ser alterados dependendo da modificação do mecanismo de elevação, ver passaporte da base para remover o amortecedor a gás:

- 1) coloque uma chave de fenda embaixo do suporte de metal;
- 2) levante o suporte para cima
- 3) remova o suporte do amortecedor do pino;
- 4) repita do lado inferior

La composición de las piezas y la secuencia de montaje puede variar en dependencia de la modificación del mecanismo de elevación. Consultar el pasaporte de la base. Para retirar el amortiguador de gas haga lo siguiente:

- 1) Coloque un destornillador de paleta debajo de la pinza de sujeción metálica
- 2) Levante la pinza de sujeción hacia arriba
- 3) Retire la fijación del amortiguador del vástago
- 4) Repítalo por el lado inferior

Die Komplettierung und die Montageordnung können sich abhängig der Modifikation

der Hebevorrichtung ändern. Siehe den Erzeugnisspass der Platte.

Um die Gasfeder abzumontieren:

- 1) Positionieren Sie den flachen Schraubenzieher unter die Metallschelle der Festigung;
- 2) Heben Sie die Schelle;
- 3) Nehmen Sie die Festigung der Gasfeder vom Nagel ab;
- 4) Wiederholen Sie von der unteren Seite.

Η ολοκλήρωση και η σειρά συναρμολόγησης μπορούν να αλλάξουν ανάλογα με την τροποποίηση της διάταξης ανύψωσης. Δείτε το διαβατήριο προϊόντος της πλάκας.

Για να αφαιρέσετε το ελατήριο αερίου:

- 1) Τοποθετήστε το κατσαβίδι κάτω από το μεταλλικό σφιγκτήρα της στερέωσης;
- 2) ανασηκώστε το σφιγκτήρα;
- 3) Αφαιρέστε τη στερέωση του ελατηρίου αερίου από το καρφί;
- 4) Επαναλάβετε από την κάτω πλευρά.

Pabeigšanas un montāžas kārtība var mainīties atkarībā no Pacelšanas ierīces modifikācijas. Skatiet plāksnes produkta pasi.

Lai noņemtu gāzes atsperi:

- 1) novietojiet plakano skrūvgriezi zem stiprinājuma metāla skavas;
- 2) paceliet skavu;
- 3) noņemiet gāzes atsperes stiprinājumu no nagu;
- 4) atkārtojiet no apakšējās puses.

Configurația și procedura de asamblare depinde de modificarea mecanismului de ridicare. A se vedea pașaportul bazei patului. Pentru a scoate amortizorul cu gaz:

- 1) aduceți o șurubelniță plată sub suportul de împletitură metalică;
- 2) ridicați suportul în sus;
- 3) scoateți suportul amortizorului de pe știft
- 4) repetați din partea de jos.

Komplektsus ja kokkupaneku järjestus võivad olenevalt tõstemehhanismi modifikatsioonist erineda. Vt aluse pass. Gaasiamortisaatori eemaldamiseks:

- 1) liigutage lame kruvikeeraja metallist kinnitusklabri alla;
- 2) tõsta klamber üles;
- 3) eemaldage naastu küljest amortisaatori kinnitus;
- 4) korrake alumisest küljest

**Do not attempt to fold the gas-lift unit before installing it.**

**Make sure the gas-lift unit is installed correctly (rod end down). Using of gas-lift units without a mattress on the frame is prohibited and traumatic. When folding beds for the first time, in some cases a little effort is required. Close the frame without fear damaging the gas-lift units, if the frame does not close with two units installed, this may be due to the insufficient weight of the purchased mattress.**

**It is recommended:**

- 1. To remove one of the gas-lift units. Lower the bed frame with the mattress installed on it.**
  - 2. To carry out the same with a second gas-lift unit.**
  - 3. Place both units on the lifting mechanism and lower the frame.**
- This will eliminate the difficulty of folding the bed.**



No intente desplegar el elevador de gas antes de instalarlo en el producto. Asegúrese de que el elevador de gas esté instalado correctamente (con el vástago hacia abajo). Se prohíbe el despliegue de los elevadores de gas sin el colchón en el bastidor, es peligroso y puede causar traumas. Al desplegar la cama por primera vez en algunos casos se requiere un pequeño esfuerzo. Cierre el bastidor sin temor de dañar los amortiguadores. Si el bastidor no se cierra con los dos elevadores de gas instalados, esto puede deberse al peso insuficiente del colchón que ha comprado.

Se recomienda:

1. Retire uno de los elevadores de gas. Baje el bastidor de la cama con el colchón colocado.
2. Realice un procedimiento similar con el segundo elevador de gas.
3. Instale ambos elevadores en el mecanismo de elevación y baje el bastidor.

Esto eliminará la dificultad al desplegar la cama.

Nao tente dobrar o elevador de gás antes de instalá-lo no produto.

Certifique-se de que instala um elevador de gás (haste para baixo). A adição de elevadores de gás sem colchão na estrutura é proibida e traumática. Ao dobrar camas pela primeira vez, em alguns casos é necessário um pouco de esforço. Feche o quadro sem medo de danificar os amortecedores. Se a estrutura não fechar com dois elevadores a gás instalados, isso pode ser devido ao peso insuficiente do colchão adquirido.

É recomendado:

1. Remova um dos elevadores de gás. Abaixar a estrutura da cama com o colchão instalado nela.
2. Faça o mesmo com o segundo elevador de gás.
3. Instale os dois elevadores de gás no mecanismo de elevação e abaixe a estrutura.

Isso eliminará as dificuldades de dobrar a cama.

Versuchen Sie nicht, die Gasfeder zusammenzulegen, bis sie im Produkt montiert wird. Stellen Sie fest, dass die Gasfeder richtig montiert wurde (mit der Stange nach unten). Das Zusammenlegen der Gasfedern ist auf dem Rahmen ohne Matratze verboten und verletzungsgefährlich.

Beim Zusammenlegen der Betten muss man zum ersten Mal in einigen Fällen eine nicht große Mühe aufwenden.

Schließen Sie den Rahmen ohne Angst, die Stoßdämpfer zu beschädigen. Wenn der Rahmen mit zwei montierten Gasfedern nicht geschlossen wird, kann es mit dem ungenügenden Gewicht der gekauften Matratze verbunden sein.

Folgendes wird empfohlen:

1. Eine der Gasfeder abzumontieren. Den Rahmen des Bettes mit der darauf gelegten Matratze zu senken.
2. Die gleiche Handlung mit der zweiten Gasfeder auszuführen.
3. Die beiden Gasfedern auf der Hebevorrichtung zu montieren und den Rahmen zu senken.

Das beseitigt Schwierigkeiten mit dem Zusammenlegen des Bettes.

Μην επιχειρήσετε να διπλώσετε τη μονάδα ανύψωσης αερίου πριν την εγκαταστήσετε.

Βεβαιωθείτε ότι η μονάδα ανύψωσης αερίου έχει εγκατασταθεί σωστά (άκρο ράβδου προς τα κάτω). Χρησιμοποίηση οι μονάδες ανύψωσης αερίου χωρίς στρώμα στο πλαίσιο απαγορεύονται και τραυματίζονται. Όταν αναδιπλώνετε τα κρεβάτια για πρώτη φορά, σε ορισμένες περιπτώσεις απαιτείται λίγη προσπάθεια. Κλείστε το πλαίσιο χωρίς φόβο να καταστρέψετε τις μονάδες ανύψωσης αερίου. Αν το πλαίσιο δεν το κάνει κλείστε με δύο μονάδες εγκατεστημένες, αυτό μπορεί να οφείλεται στο ανεπαρκές βάρος του αγορασμένου στρώματος.

Συνιστάται:

1. Αφαιρέστε ένα από τα ελατήρια αερίου. Για να χαμηλώσετε το πλαίσιο του κρεβατιού με το στρώμα που τοποθετείται πάνω του.
2. Εκτελέστε την ίδια ενέργεια με το δεύτερο ελατήριο αερίου.
3. Τοποθετήστε τα δύο ελατήρια αερίου στη συσκευή ανύψωσης και χαμηλώστε το πλαίσιο.

Αυτό εξαλείφει τις δυσκολίες με την αναδίπλωση του κρεβατιού.

Isso eliminará as dificuldades de dobrar a cama.

Nemēģiniet salocīt gāzes atsperi, līdz tas ir uzstādīts produktā. Nemiet vērā, ka gāzes atsperi tika uzstādīti pareizi (ar stieni uz leju).

Gāzes atsperu locīšana uz rāmja bez matrača ir aizliegta un bīstama traumām. Saliekot gultas Pirmo reizi, dažos gadījumos ir nepieciešams tērēt ne daudz pūļu. Aizveriet rāmi, nebaidoties sabojāt amortizatorus. Ja rāmis ar divām montētām gāzes atsperēm nav aizvērts, tas var būt saistīts ar iegādātā matrača nepietiekamo svaru.

Ieteicams sekojošais:

1. Noņemiet vienu no gāzes atsperēm. Lai nolaiestu gultas rāmi ar uz tā uzlikto matraci.
2. Veiciet to pašu darbību ar otro gāzes atsperi.
3. Uzstādiet divas gāzes atsperes uz Pacelšanas ierīces un nolaidiet rāmi.

Tas novērš grūtības ar gultas locīšanu.

Nu încercați să pliați amortizorul cu gaz înainte de a-l instala pe produs.

Asigurați-vă că amortizorul cu gaz este instalat corect (cu tija orientată în jos). Adăugarea amortizoarelor cu gaz fără saltea pe cadru este interzisă și traumatică. Când pliați patul pentru prima dată, în unele cazuri este necesar să faceți un efort mic. Închideți cadrul fără teama de a deteriora amortizoarele. Dacă cadrul nu se închide cu două amortizoare cu gaz instalate, aceasta poate rezulta din greutatea insuficientă a saltelei achiziționate.

Recomandări:

1. Scoateți unul dintre amortizoare cu gaz. Coborâți rama patului cu salteaua instalată pe ea.
2. O procedură similară trebuie efectuată cu cel de-al doilea amortizor cu gaz.
3. Instalați ambele amortizoare cu gaz pe mecanismul de ridicare și coborâți cadrul.

Aceasta va elimina dificultățile legate de plierea patului.

Ärge püüdke gaasitõstukit enne tootele paigaldamist kokku voltida.

Veenduge, et gaasitõstuk oleks õigesti paigaldatud (varva all). Gaasitõstukite voltimine ilma madratsita raamile on keelatud ja traumaatiline. Voodite esmakordsel voltimisel tuleb mõnel juhul veidi vaeva näha. Sulgege raam, kartmata amortisaatorite kahjustamist. Kui raam ei sulgu kahe paigaldatud gaasitõstuki korral, võib põhjuseks olla osetud madratsi ebapiisav kaal.

Soovitav:

1. Eemaldage üks gaasitõstukidest. Langetage voodiraam koos sellele paigaldatud madratsiga.
2. Tehke sama protseduur teise gaasitõstukiga.
3. Paigaldage mõlemad gaasitõstukid tõstemehhanismile ja langetage raam. See välistab voodi voltimise raskused

33)

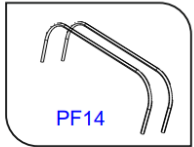
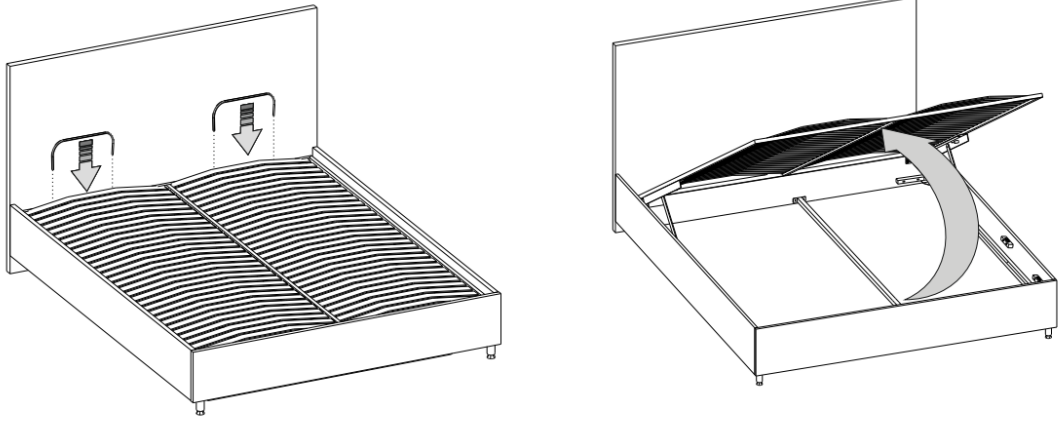

PF14

34)

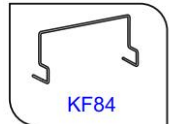
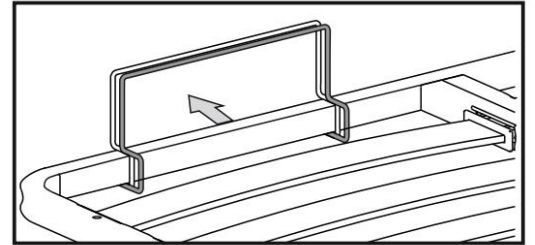
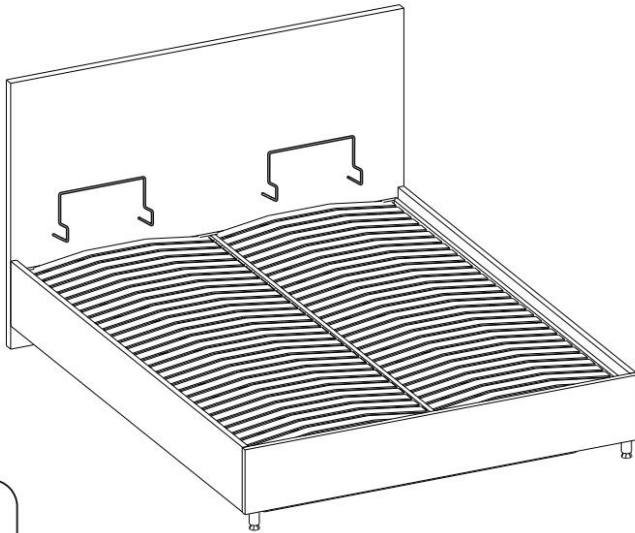

KF84

35)

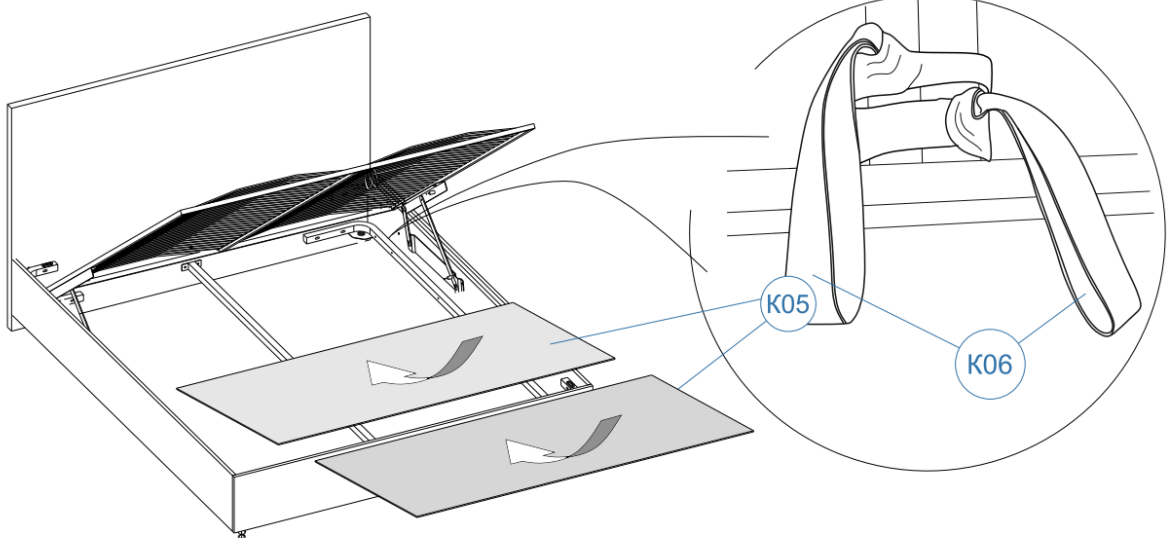

K05

K06

**This step refers only to beds with a removable case and rails fully upholstered with technical fabric! If rails are upholstered with furniture fabric or faux leather go to p. 38.**

Isto é apenas para as camas com uma capa removível e barras totalmente estofadas em tecido técnico! Se a barra esta forrada com o tecido ou eco couro- segue para o ponto 38.

¡Solo para camas con funda extraíble y bastidores completamente tapizados con lona de algodón! Si el bastidor del mueble es de tela o cuero sintético, vaya al paso 38.

Nur für Betten mit entfernbarem Bezug und Zargen, die völlig mit Padding bezogen sind!

Αυτό ισχύει μόνο για κρεβάτια με αφαιρούμενα καλύμματα και σφάγια πλήρως επενδυσμένα με τεχνικό ύφασμα!

Εάν το σφάγιο είναι επενδυσμένο με ύφασμα επίπλων ή οικολογικό δέρμα - προχωρήστε στο βήμα 38.

Tas ir paredzēts tikai gultām ar noņemamiem pārvalkiem un apaļtapām, kas pilnībā apšūtas ar tehnisko audumu!

Ja apaļtapa ir apdare audumā vai eko-ādā - pārejiet uz 38 darbību

Punctul acesta este numai pentru paturi cu acoperire detașabilă și cadru tapițat complet în țesătură tehnică! Dacă cadru este tapițat în țesătură de mobilier sau piele ecologică, referiți la punctul 38.

Etapp ainult eemaldatavate katetega ja üleni tehnilise kangaga polsterdatud tsargatega voodite! Etapp ainult eemaldatavate katetega ja üleni tehnilise kangaga polsterdatud tsargatega voodite! Kui tsargad on mööblikangast või ökonahast, jätkake punktiga 38.

36)

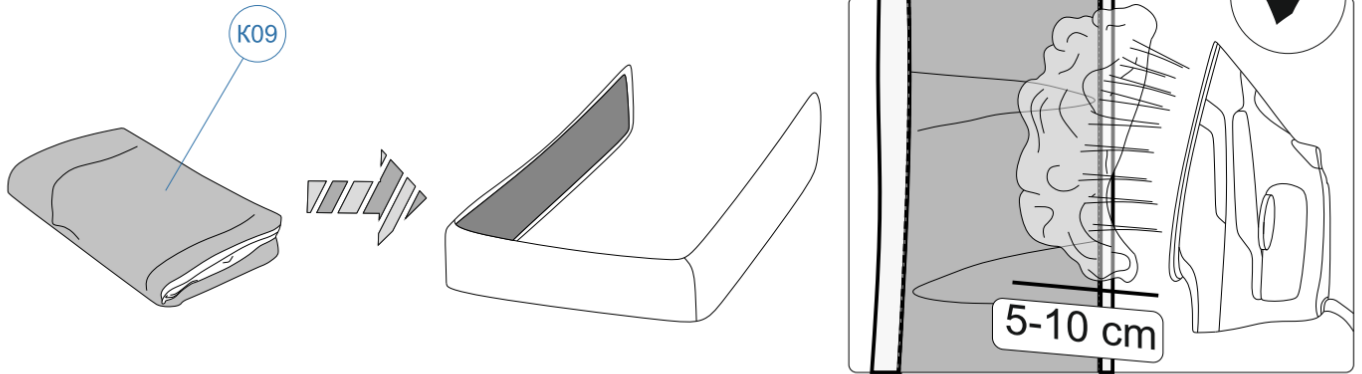

**This step refers only to beds with a removable case and rails fully upholstered with technical fabric!**

Isto é apenas para as camas com uma capa removível e barras totalmente estofadas em tecido técnico!

¡Solo para camas con funda extraíble y bastidores completamente tapizados con lona de algodón!

Nur für Betten mit entfernbarem Bezug und Zargen, die völlig mit Padding bezogen sind!

Αυτό ισχύει μόνο για κρεβάτια με αφαιρούμενα καλύμματα και σφάγια πλήρως επενδυσμένα με τεχνικό ύφασμα!

Tas ir paredzēts tikai gultām ar noņemamiem pārvalkiem un apaļtapām, kas pilnībā apšūtas ar tehnisko audumu!

Punctul acesta este numai pentru paturi cu acoperire detașabilă și cadru tapițat complet în țesătură tehnică!

Etapp ainult eemaldatavate katetega ja üleni tehnilise kangaga polsterdatud tsargatega voodite!

37)

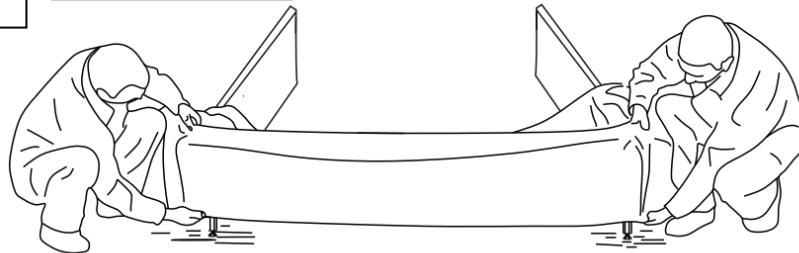
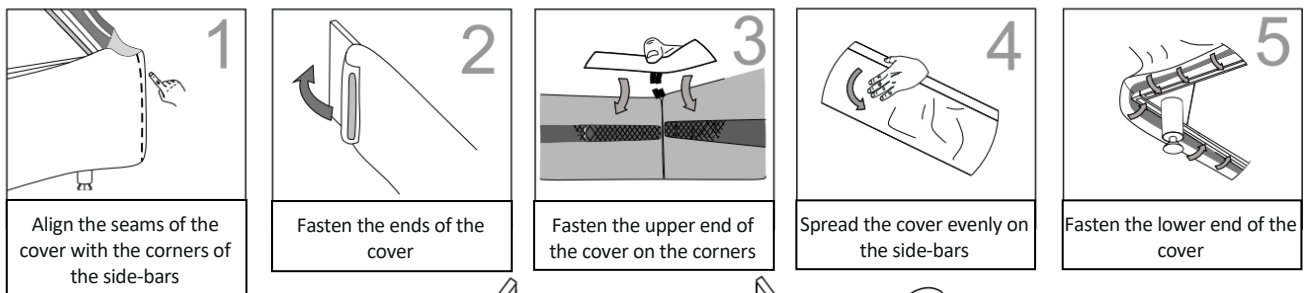

38)

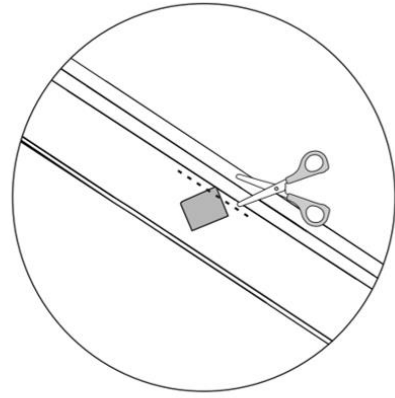
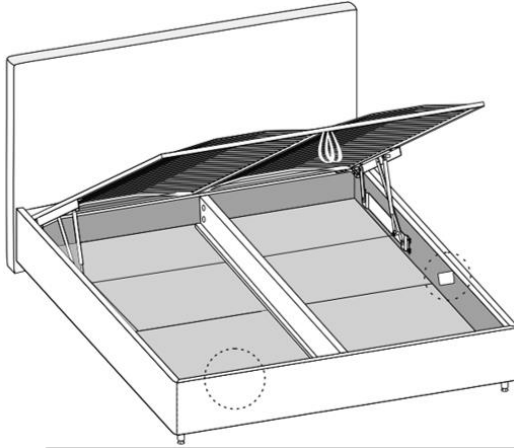

**If necessary, the cloth specimen can be cut off or tucked under a removable cover/**  
 Si es necesario, la muestra del material se puede recortar u ocultar debajo de la funda removible /  
 Uma amostra de material pode ser cortada ou dobrada sob uma tampa removível, se necessário /  
 Im Falle der Notwendigkeit kann das Stoffmuster abgeschnitten oder in den entfernbaren Bezug gestopft werden  
 Εάν είναι απαραίτητο, δείγμα υλικού μπορεί να κοπεί ή να τοποθετηθεί κάτω από το αφαιρούμενο κάλυμμα /  
 Nepieciešamības gadījumā, materiāla paraugu var nogriezt vai ielikt zem noņemama pārvalka /  
 Dacă este necesar, un eșantion de țesătură poate fi tăiat sau ascuns sub acoperire detașabilă /  
 Vajadusel saab kangenäidist ära lõigata või eemaldada eemaldatava katte alla

39)

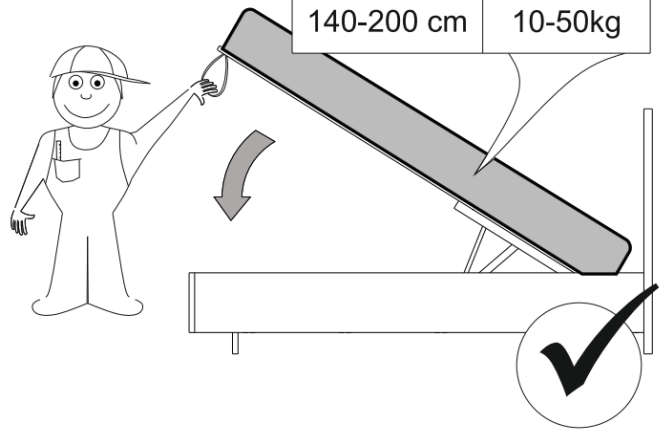
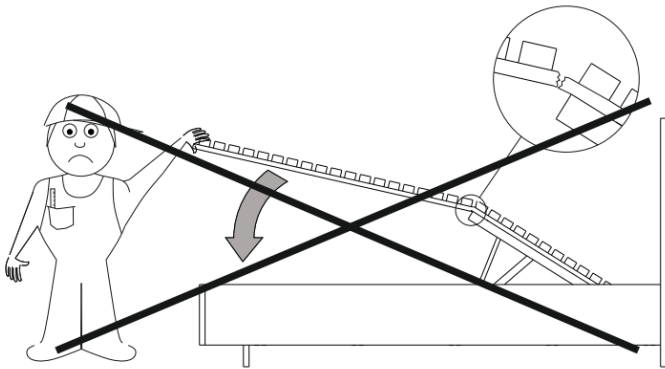

40)

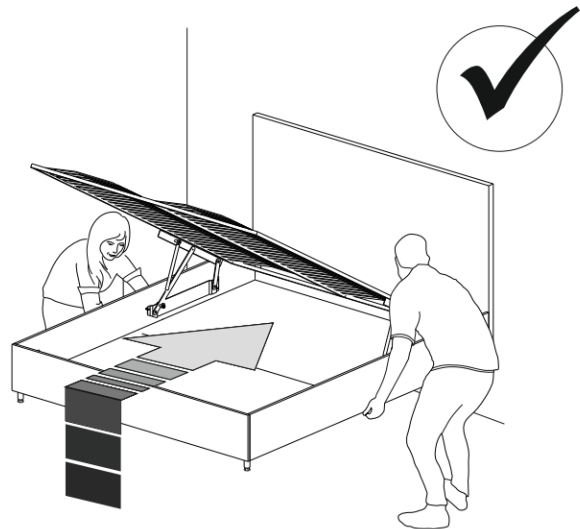
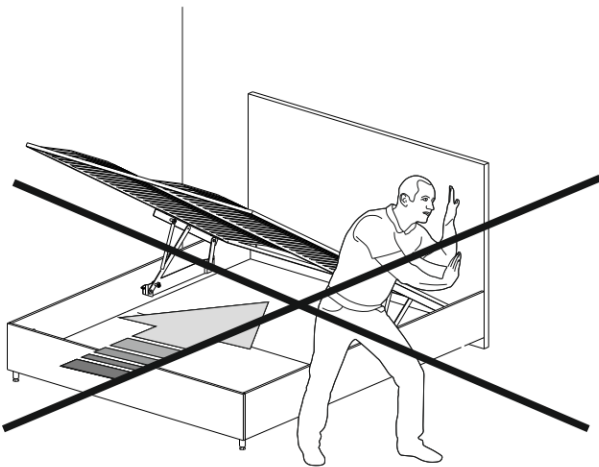

41)

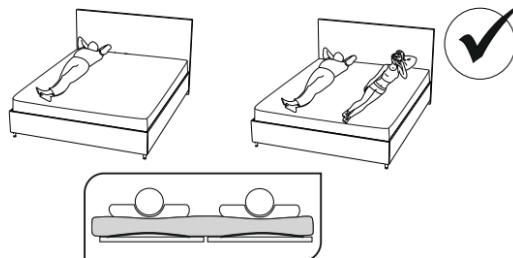
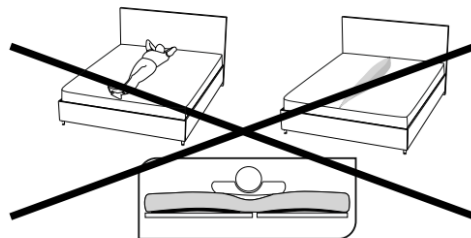
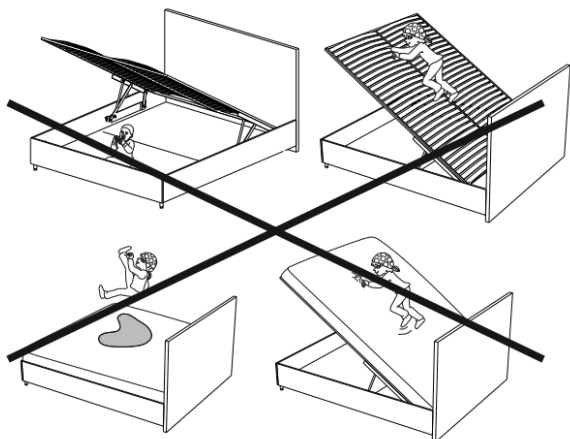

42)

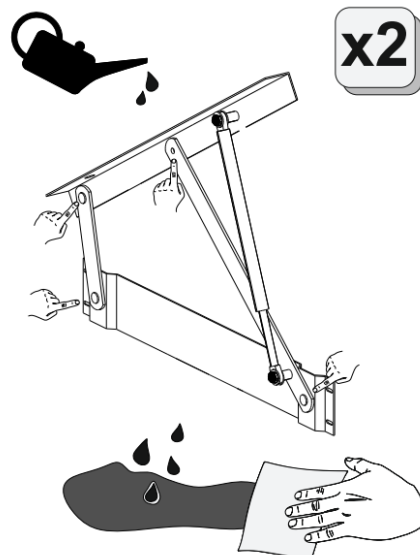
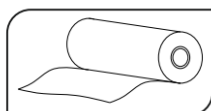
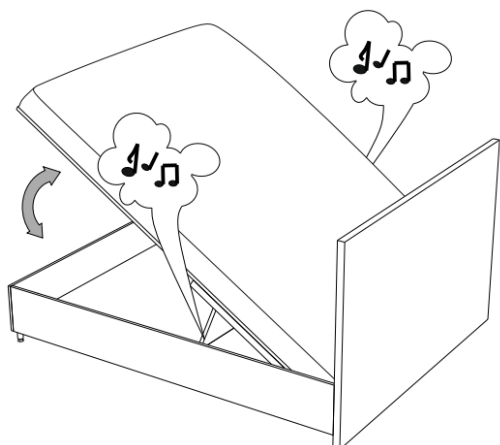

43)

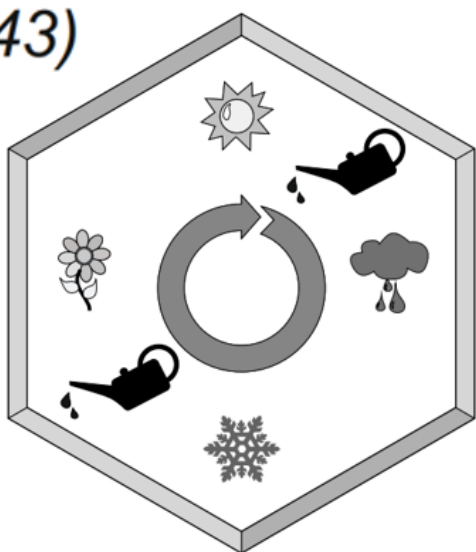

**You should lubricate the moving parts of the mechanism at least 2 times per year /**

Debe lubricar las partes con fricción del mecanismo al menos 2 veces al año /

Precisa fazer um Lubrificar as partes móveis do mecanismo pelo menos 2 vezes por ano/

Man muss Schmierem die reibenden Teile der Vorrichtung nicht seltener als 2 Male im Jahr durchführen./

Θα πρέπει να λιπαίνετε τα κινούμενα μέρη του μηχανισμού τουλάχιστον 2 φορές το χρόνο /

Jums vajadzētu ieeļļot mehānisma kustīgās daļas vismaz 2 reizi gadā /

Este necesar să lubrifiați părțile de frecare ale mecanismului de cel puțin 2 ori pe an /

Mehhanismi hõõrduvaid osi tuleks määrida vähemalt 2 korda aasta tagant