

# SUNSET NOVA

EN

ES

PT

LV

EL

ET

RO

FR

HE

DE

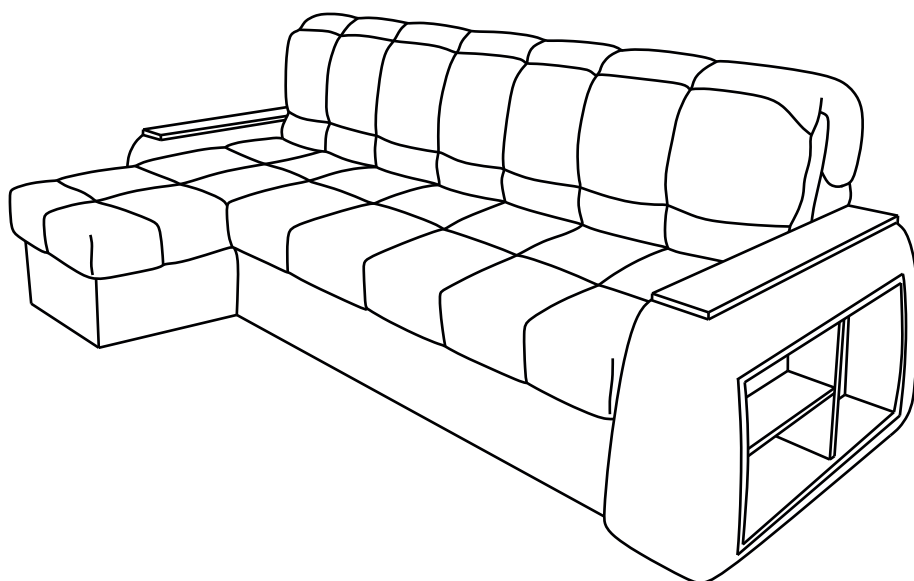
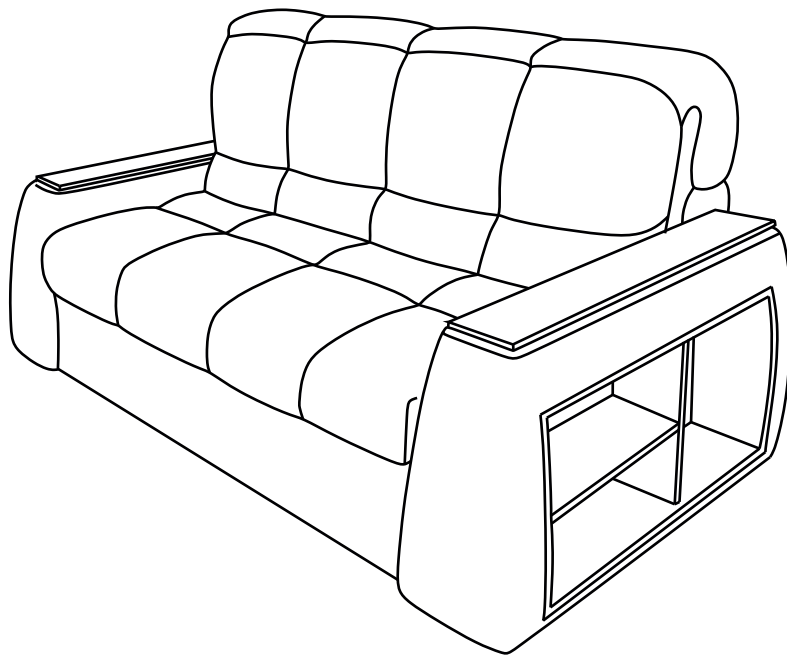

Sleep.8

# SUNSET NOVA



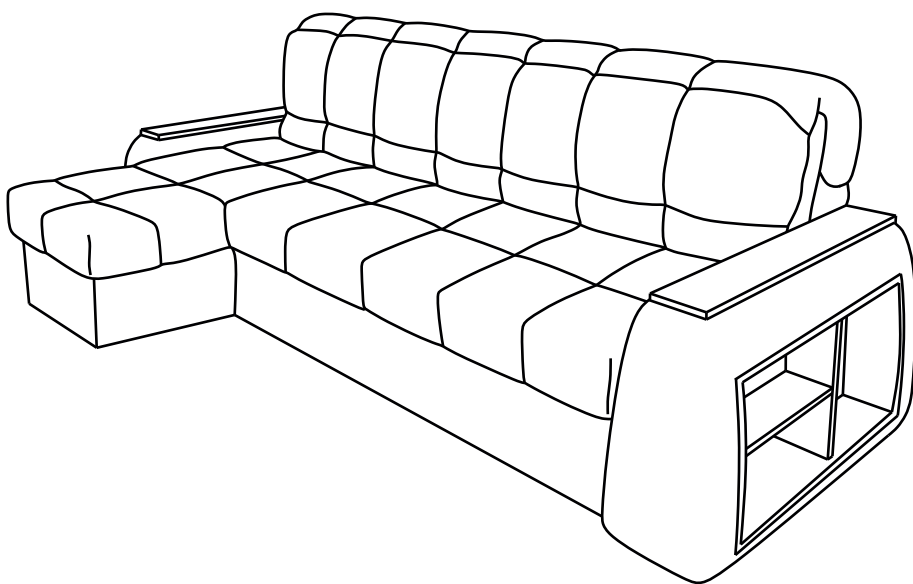
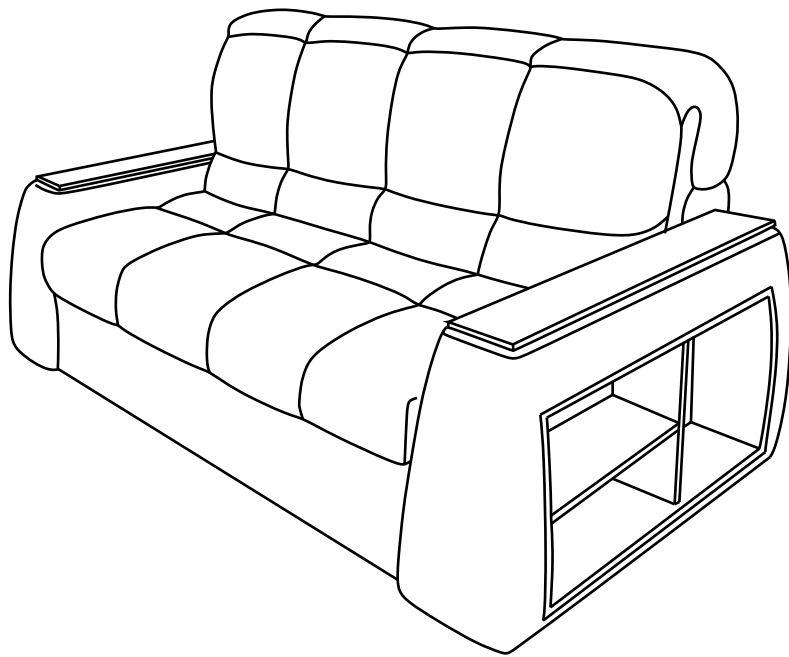





EN

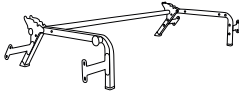



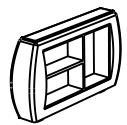
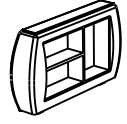
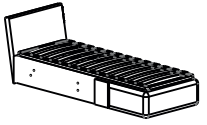

Sleep.8

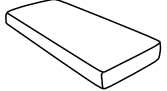



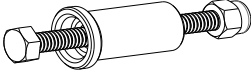
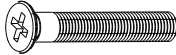

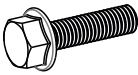
### Parts List

Package	Figure	Part marking	Name	Quantity
N° 1		D01	Transformation mechanism	1
		D26	Transformation mechanism support	1
		D04	Back	1
		D05	Side bar	1
		D07	Quilted sofa cover	1
			Assembly instructions	1
			Package with accessories	1
N° 2		D06	Armrest	1
N° 3		D06	Armrest	1
N° 4 Additional option		D14	Canape	1
		D11	Canape cushion	1
		D08	Canape cover	1
			Package with accessories	1
			Assembly instructions	1
Bought separately		D20	Sofa mattress	1
		D21	Canape mattress	1

### List of sofa fittings

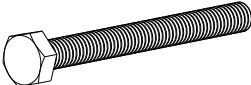
Package	Figure	Part marking	Name	Quantity
Package with accessories		DF02 DF15 DF16	Bolt M6x65 Plastic insert Nut (self-locking)	2
		DF11	Sunk screw M6x30	3
		DF31	Spring with hooks	2
		DF06	Bolt M8x45	4
		DF56	Bolt M8x30	8
		DF42	Washer M8	4

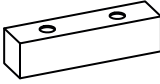
### List of canape fittings

Package	Figure	Part marking	Name	Quantity
Package with accessories		DF30	Canape spring	2
		DF09	Bolt M8x80	12
		DF19	Nut M8	6
		DF42	Washer M8	14
		DF74	Canape frame extender	4
		DF75	Mechanism stopper	2

6YZcfY UggYa V'm

⌘7\YW\ h\Y dUW\U[ Yfj]Vt a dcbYbhdUfhg Zcf Ubm\fyU\_U[ Yg'cf j ]g]V'Y XYZVWg° Claims concerning damage will only be processed if there are NO signs of attempted assembly.

&⌘?YYd U`dUW\U[ ]b[ UbX ]bghfi W]cbgi bh]` UggYa V'm]gVt a d`YhY` °⌘, during assembly, parts are found to be missing or damaged, make sure to keep the package until a company representative is dispatched to your location.

' ⌘7\YW\ h\Y bi a VYf'cZdUfhg UbX Z]h]b[ g U[ U]bghh\Y` ]gh" The manufacturer reserves the right to make structural changes to the product, and to replace fittings and metal components with equivalents, which have no negative impact on the product's appearance or function. In the case of missing or damaged fittings, circle the number of the missing item and inform the store to receive a replacement.

(⌘: c`ck h\Y UggYa V'm]bghfi W]cbg ]b h ]g XcW a Ybh° If the instructions for assembly and use are not followed, the manufacturer's warranty obligations are withdrawn.



) ⌘-bghU` h\Y Vt bj Yfh]V'Y gcZUVYX'cb U`Yj Y` Zccf gi fZUW° On uneven floors or thick carpets, the convertible sofa bed's folding mechanism may not work properly or the product may become deformed.

\* ⌘8c bchUggYa V'Y h\Y Vt bj Yfh]V'Y gcZUVYX U'cbY° Two people are required. Move all the component parts carefully and avoid pulling them forcefully. Lay everything down carefully so that the fittings do not fall on or hit anything!

+⌘Cb`mfU]gY Zi fb]hi fy UbX ]hg Vt a dcbYbhdUfhg U` ]hY cZZh\Y [ fci bX k \Yb'a cj ]b[ h\Ya U'fci bX" This will help prevent distortions and breakages.

, ⌘K \] ghUggYa V ]b[ zVY gi fy hc [ fyUgY h\Y Zc`X]b[ 'a YW Ub]ga UgXYH] YX ]b h\Y ]bghfi W]cbg° This will help prevent squeaking noises. Repeat greasing and tighten obviously loose nuts and bolts at least every 6 months.

: cf UggYa V'mnci k ]` bYYX.

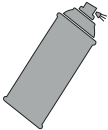
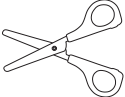
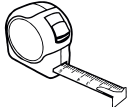
	Phillips-head screwdriver
	Spanner №13 x 1 Spanner №10 x 2
	Paper towels
	Silicone lubricant spray
	Scissors
	Tape measure

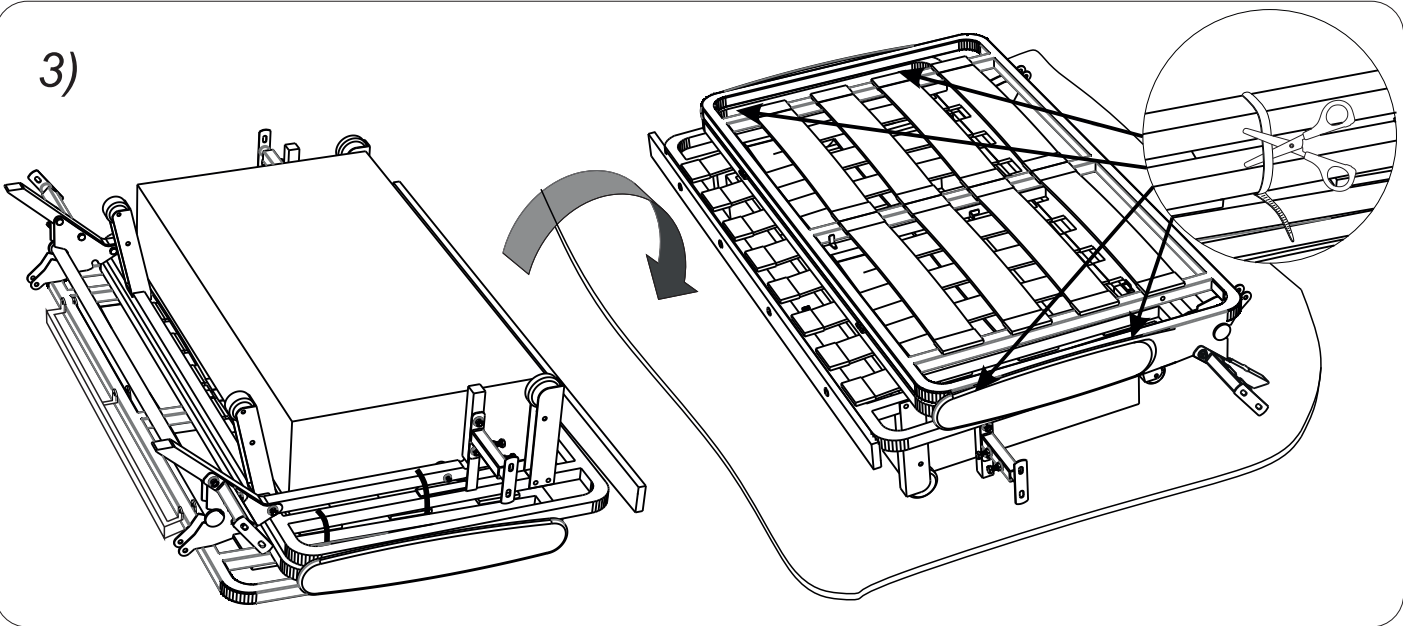
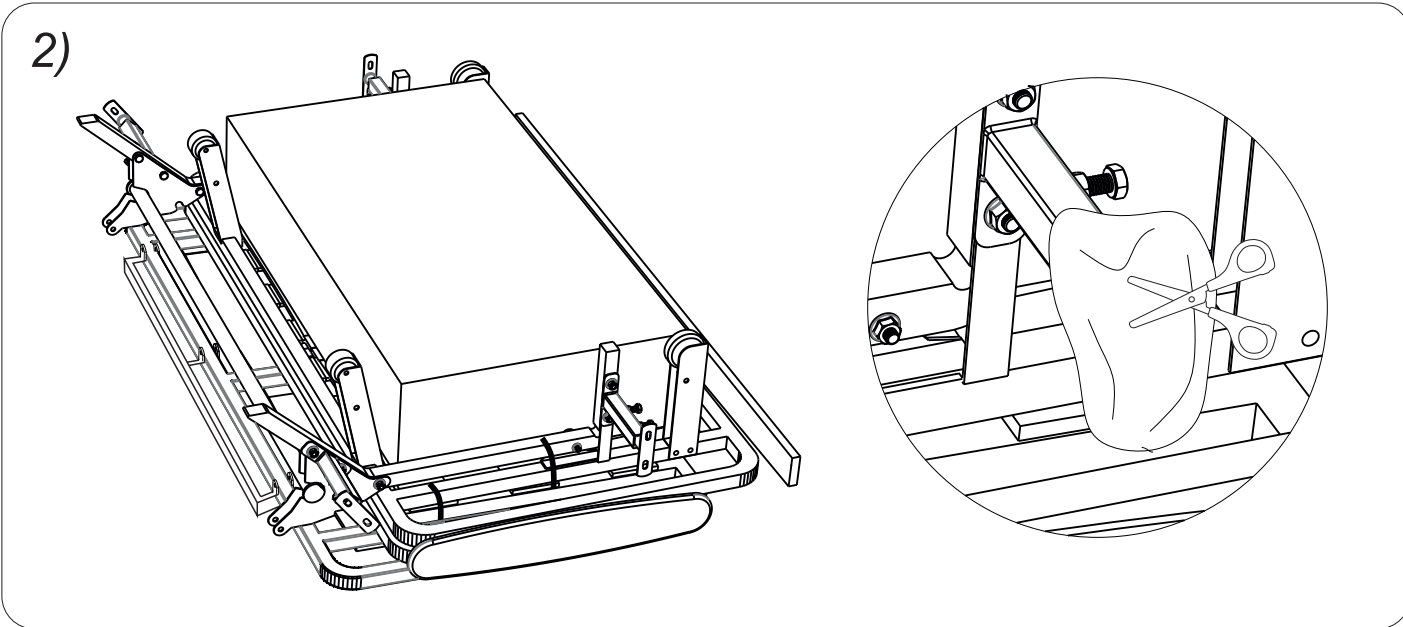
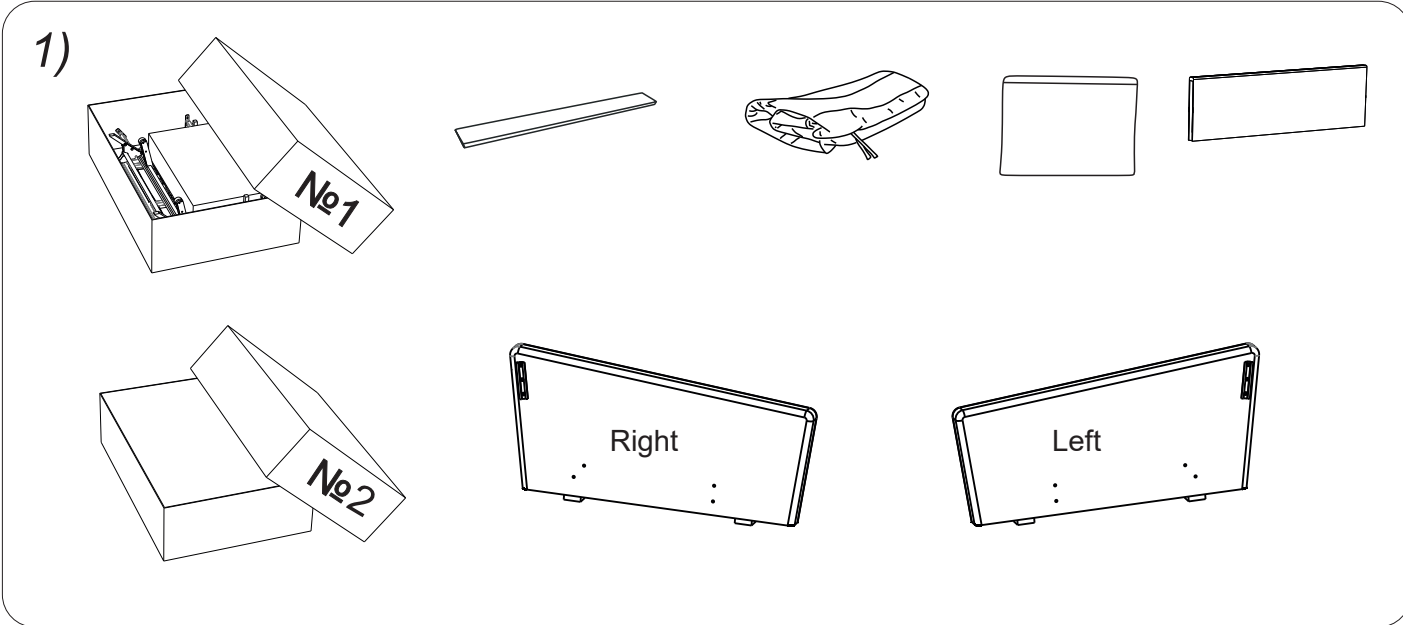

4)

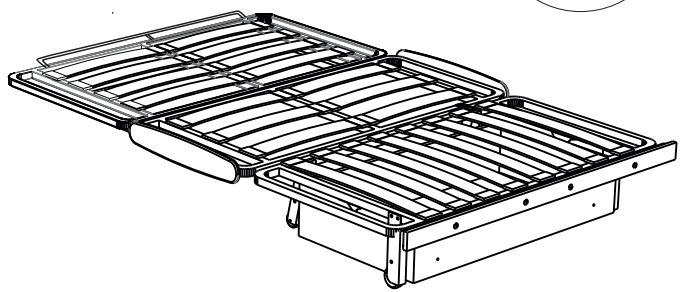
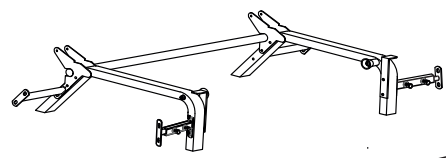
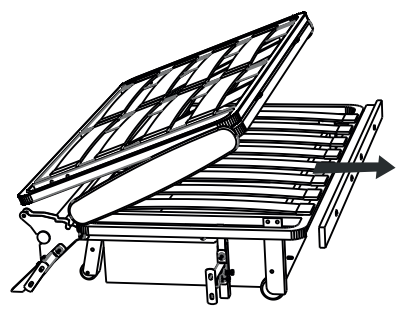

Remove the frame from the plinth

5)

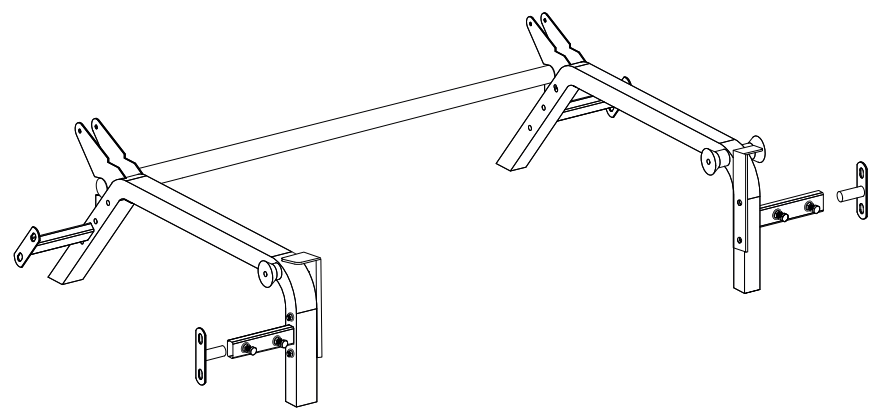
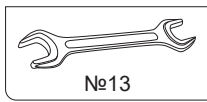
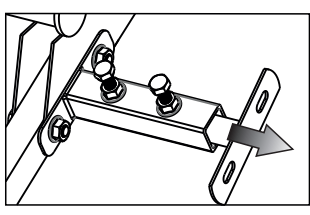
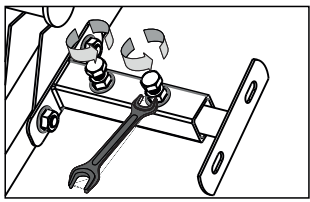

6)

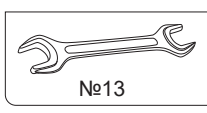
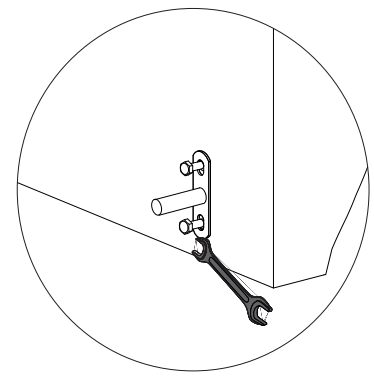
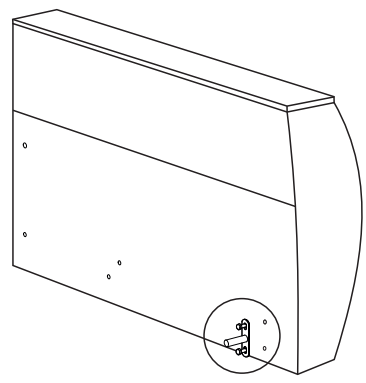
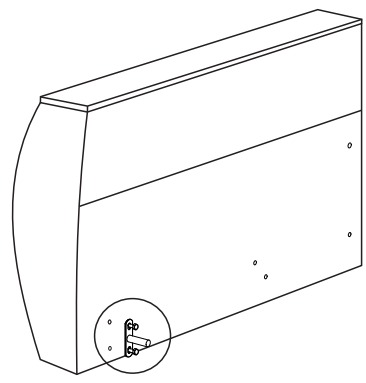

7)

Do not tighten the bracket bolts.

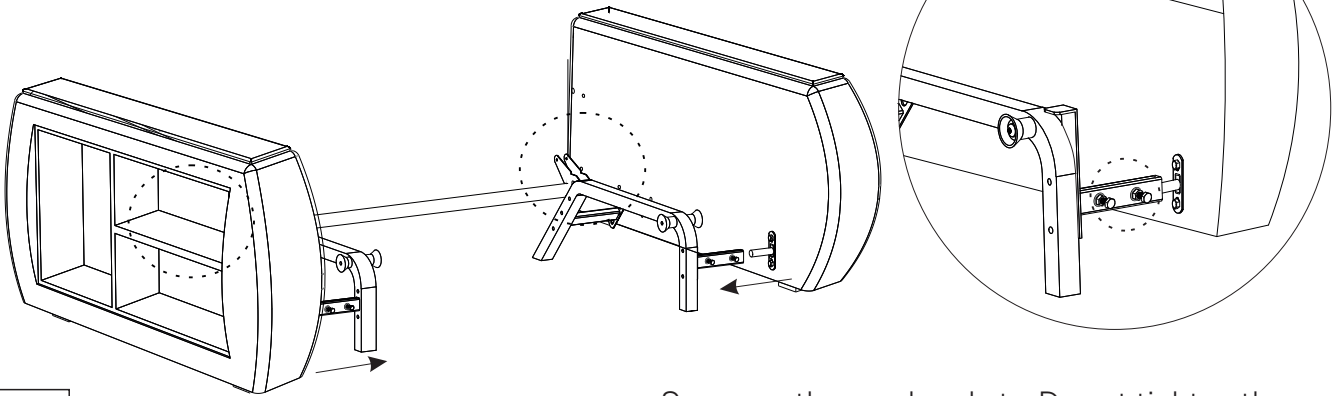

Screw on the rear brackets. Do not tighten the bolts of the front brackets.

8)

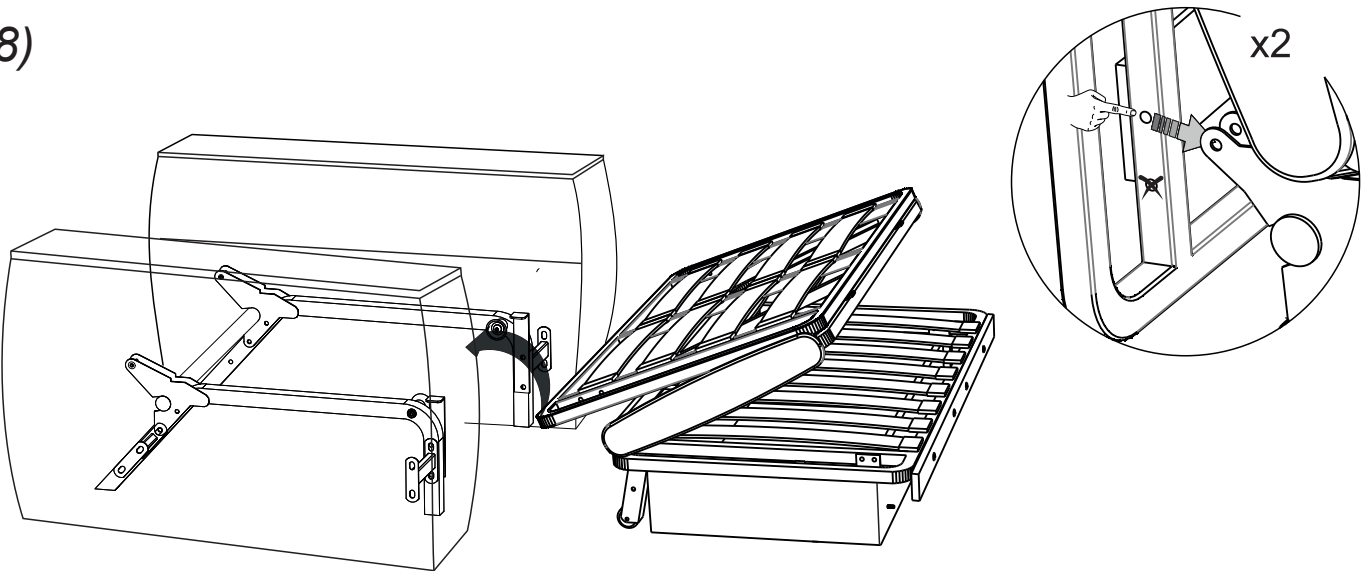

Do not tighten too much

9)

x2

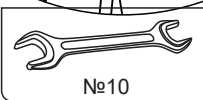
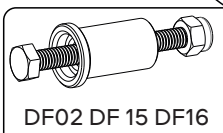
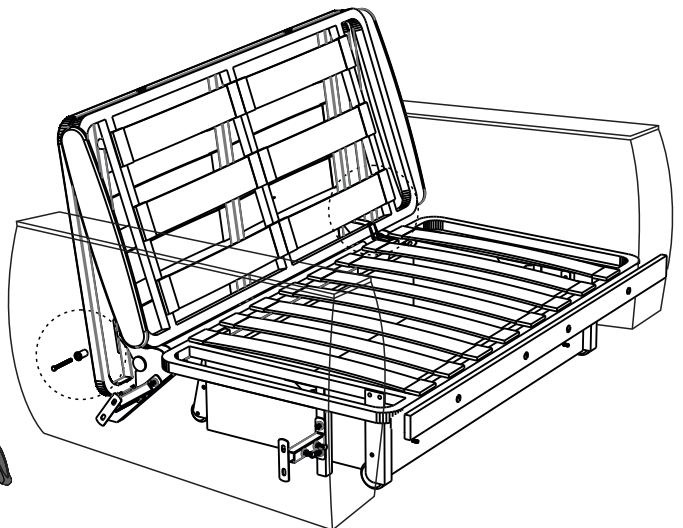
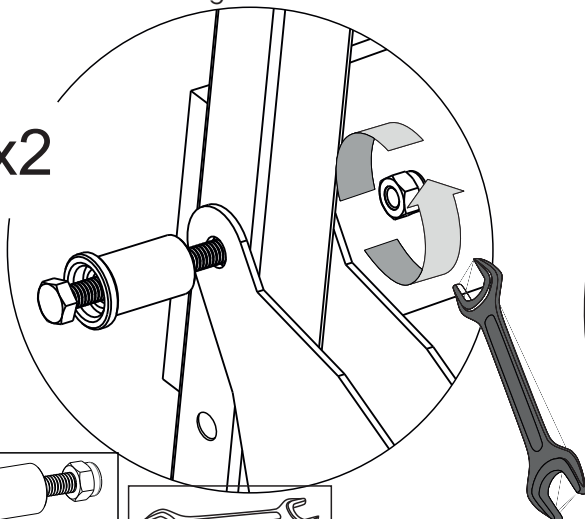

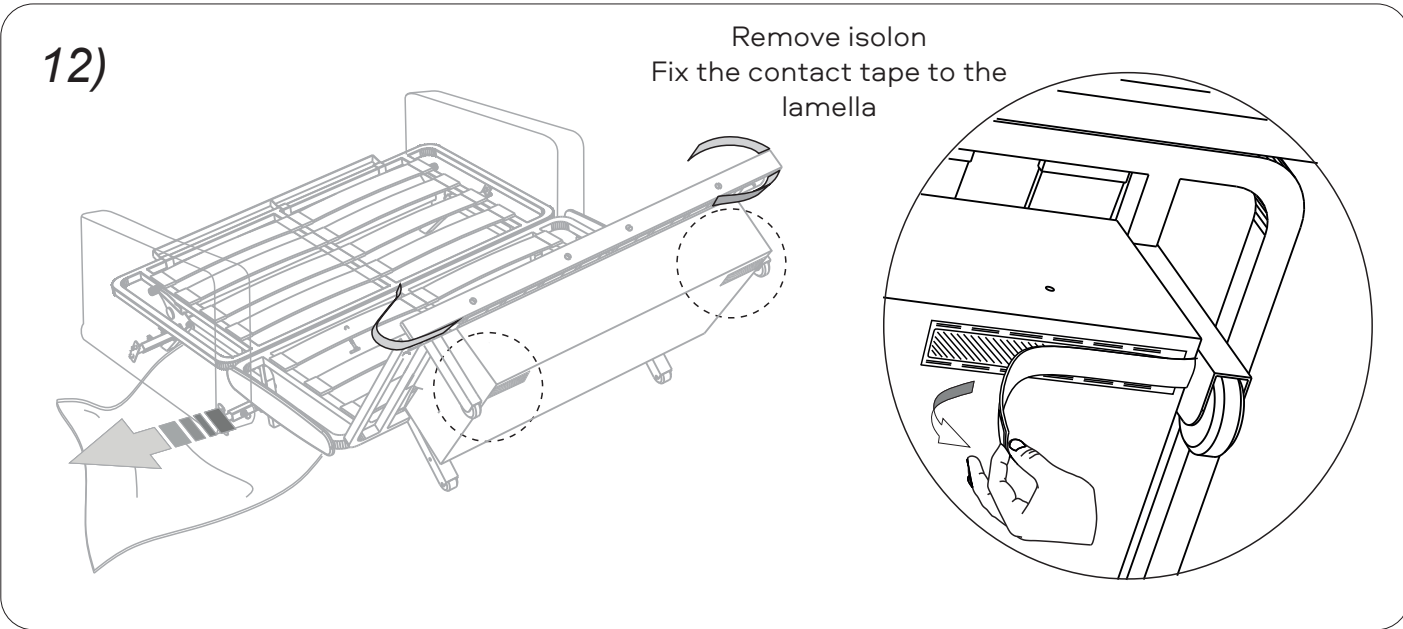
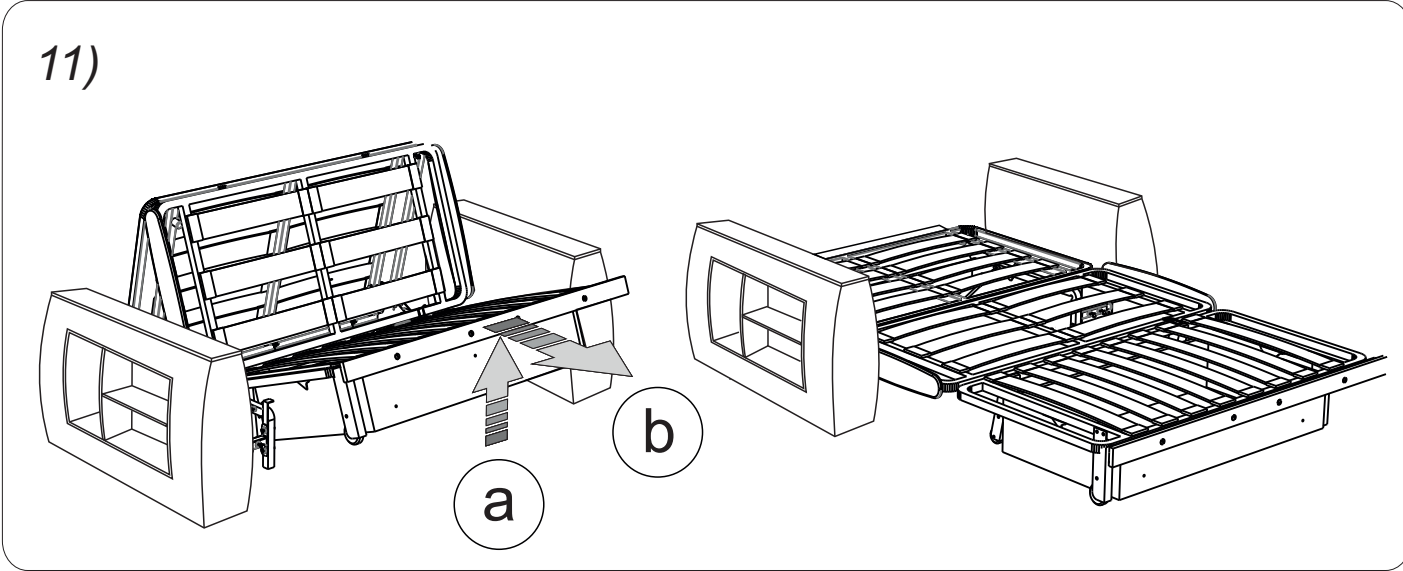
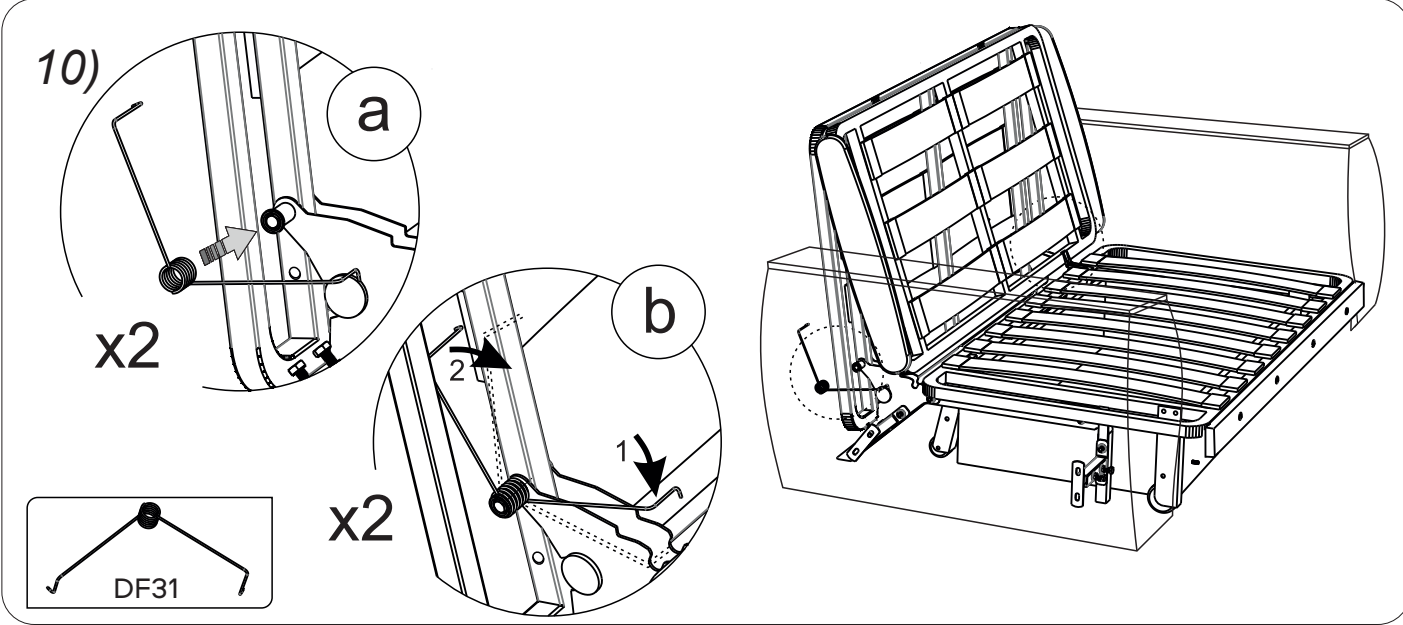



13)

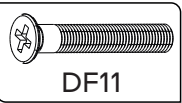
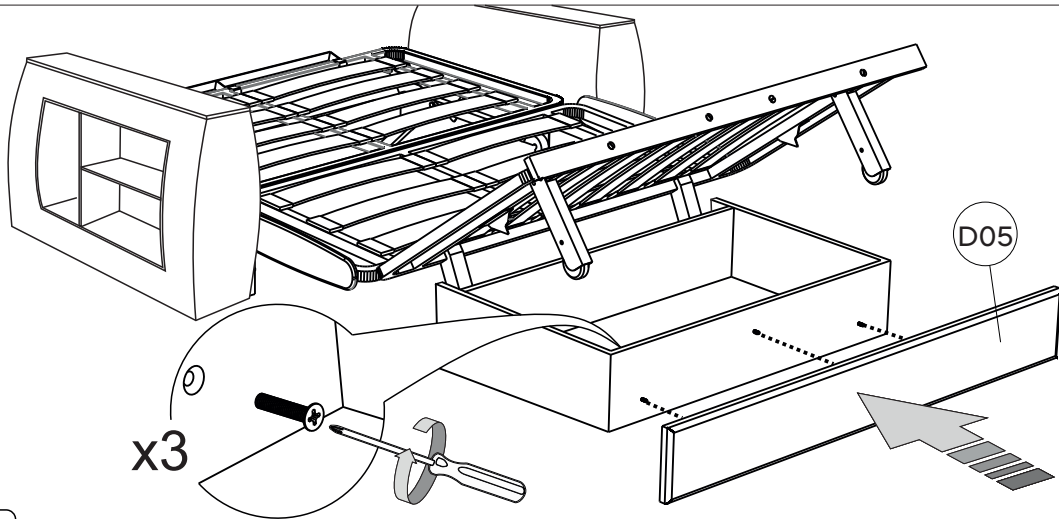

The bottom of the side bar is determined by the presence of a staple strip

14)

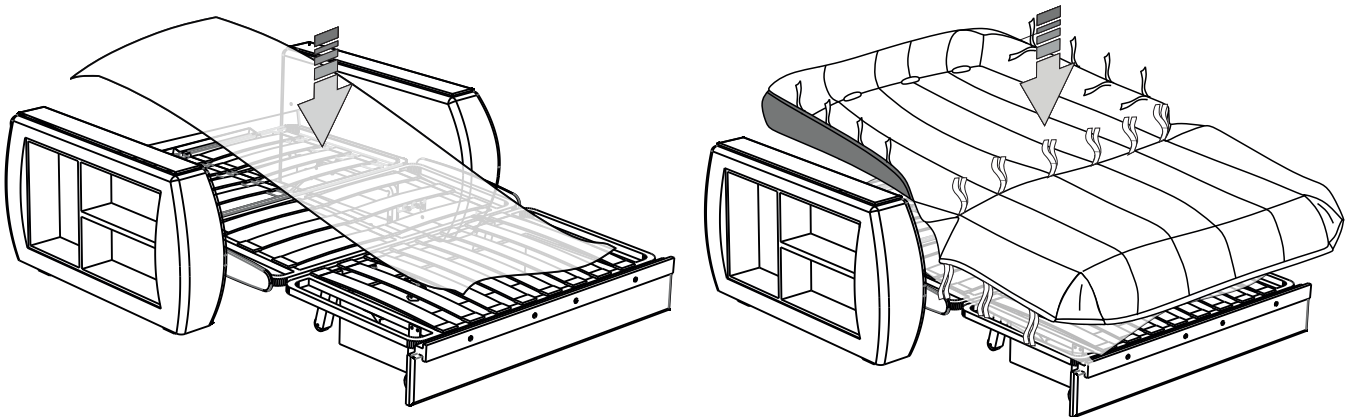

Lay film from the sofa packaging on the mechanism to protect the cover from grease.

15)

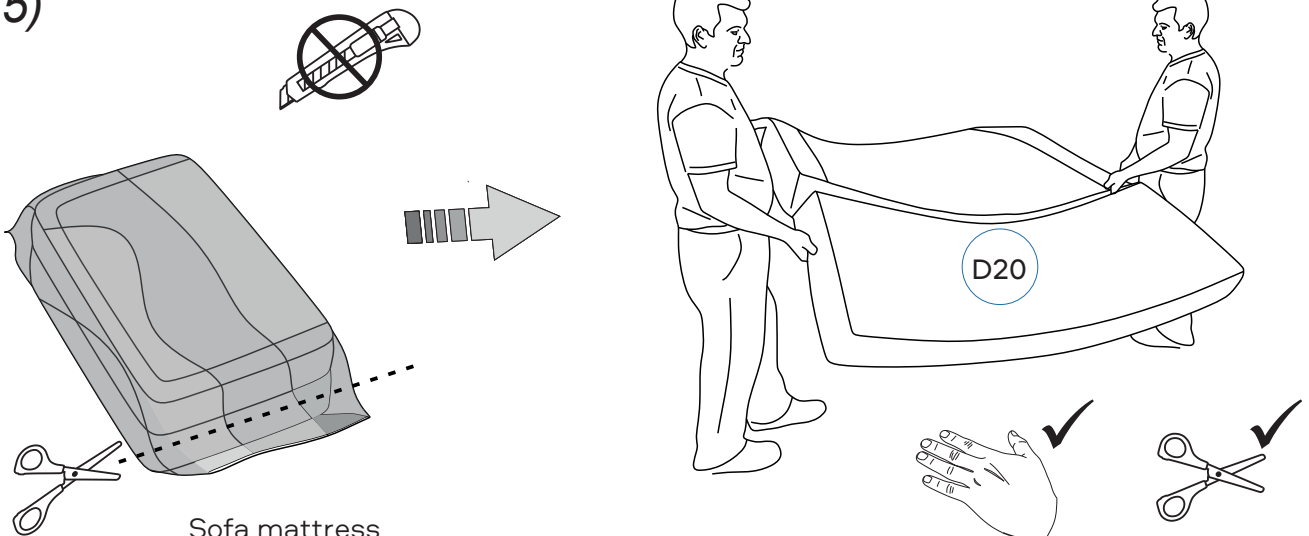

Sofa mattress



16)

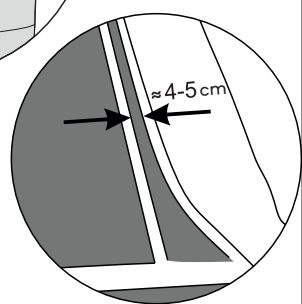
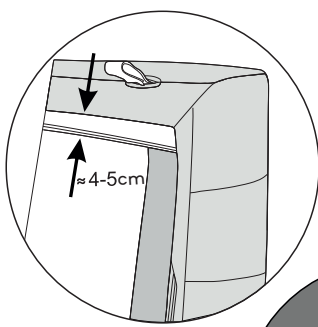
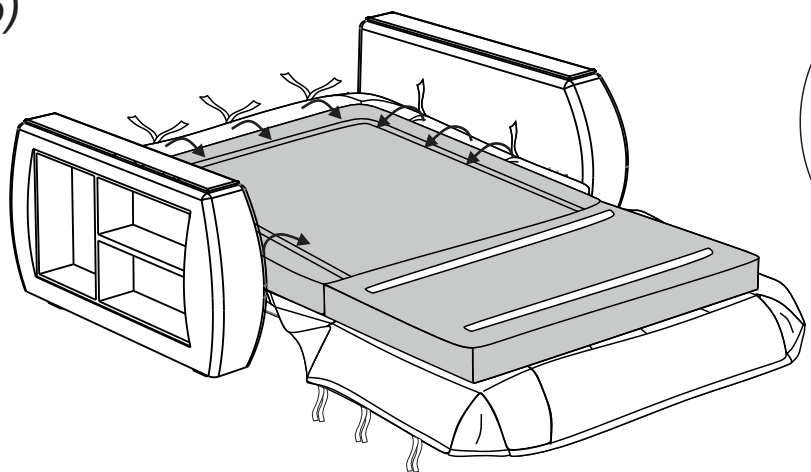

Level out seams and corners of mattress and cover.  
At the headboard, thread the Velcros through the cover holes.

17)

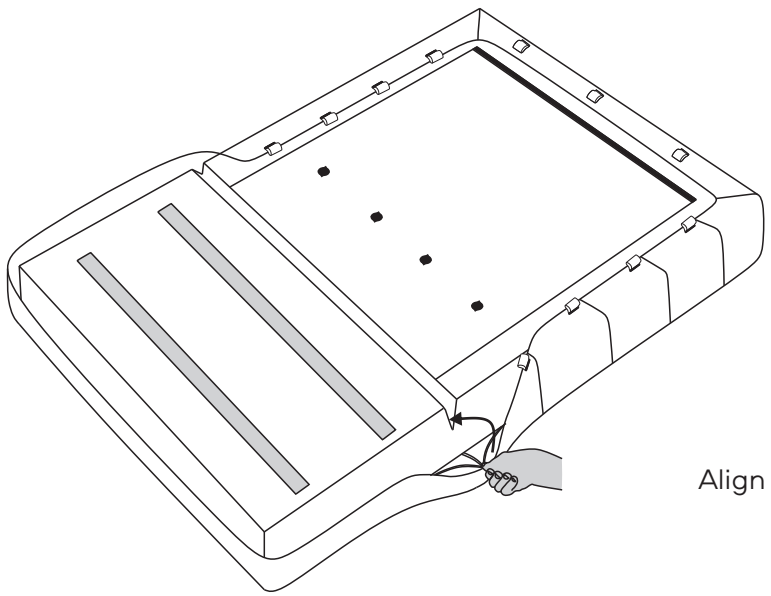

Align seams of cover and mattress.

18)

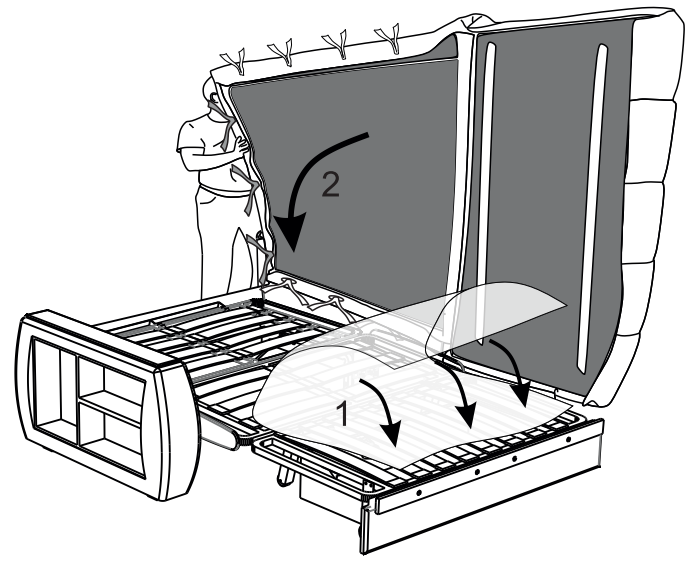

19)

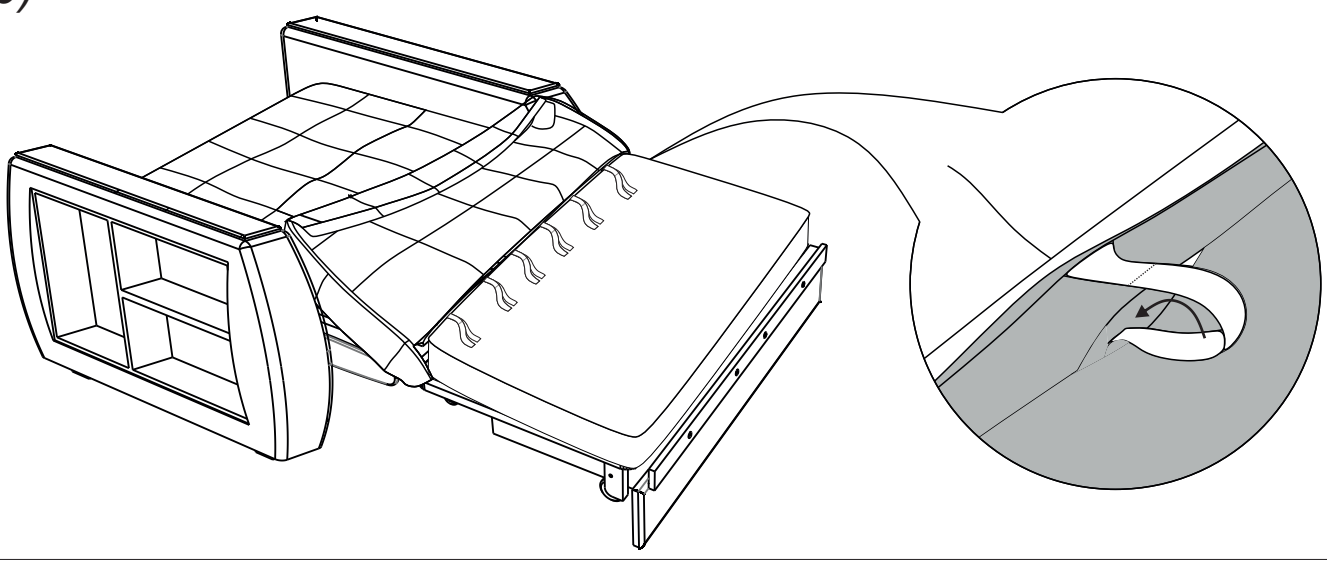

20)

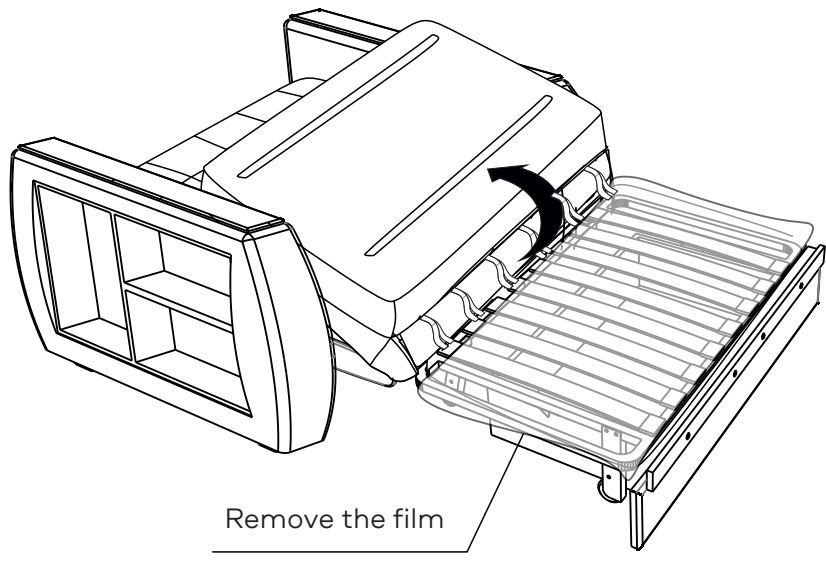

Remove the film

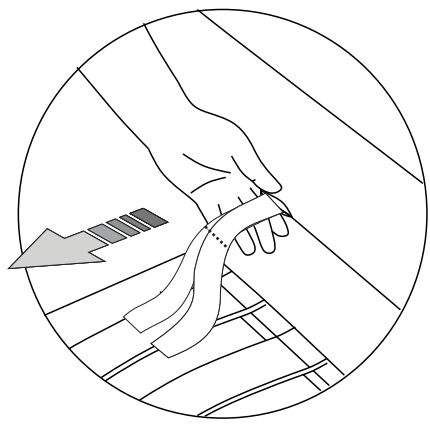

21)

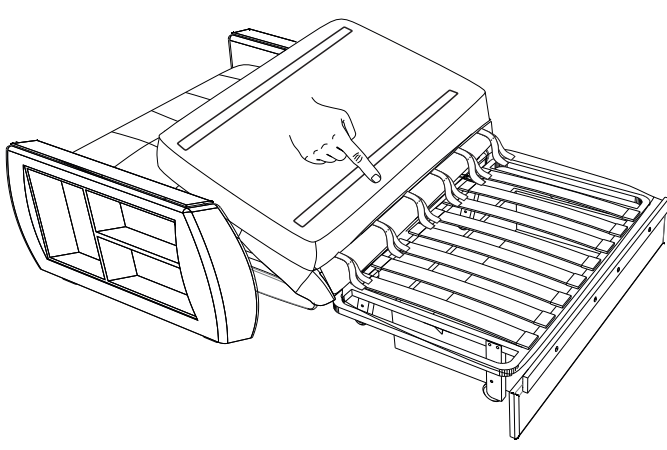

✘

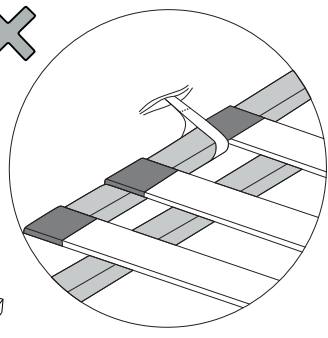

✔

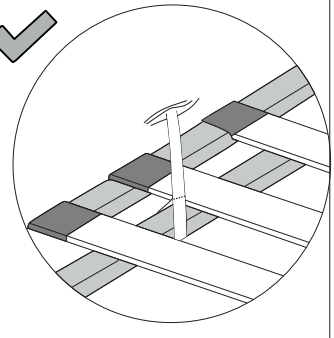

Engage Velcros by pulling them tight up to the sewing line.

22)

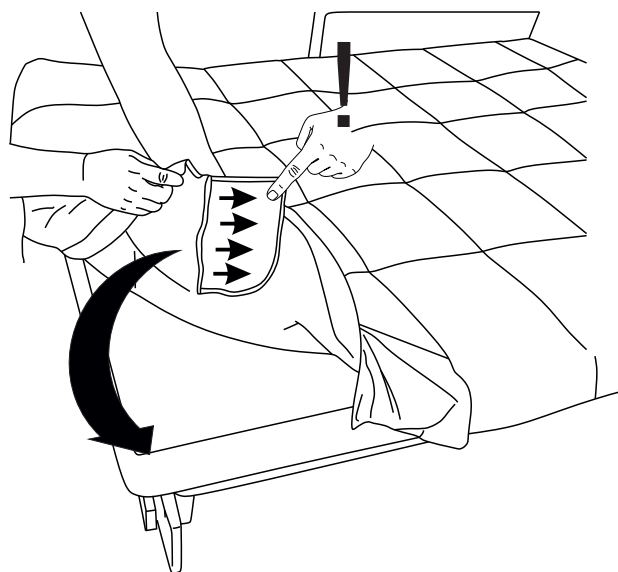
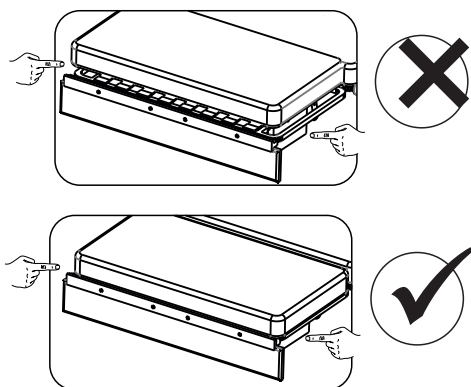

The mattress should protrude beyond the edge of the rail by no more than 1 cm.

23)

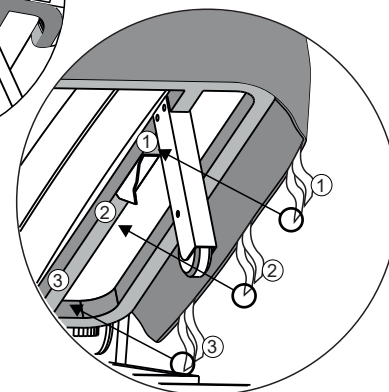
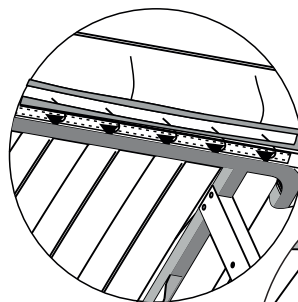
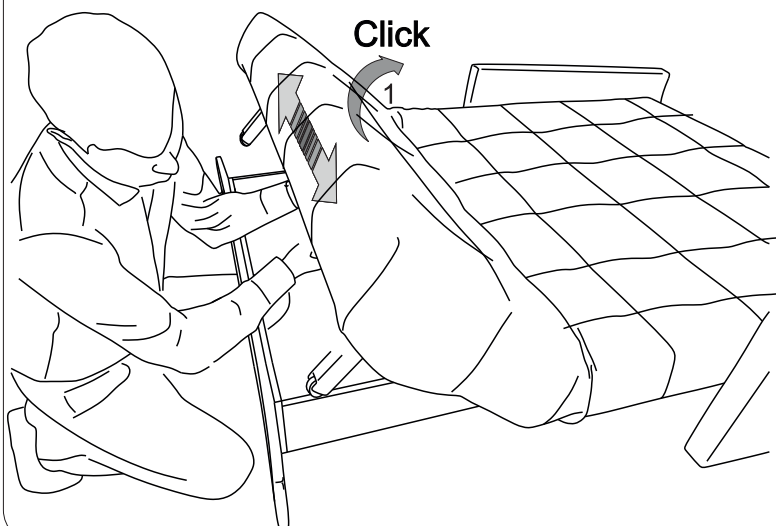

24)

Collect excess cover at the fold of the mattress to facilitate the transformation

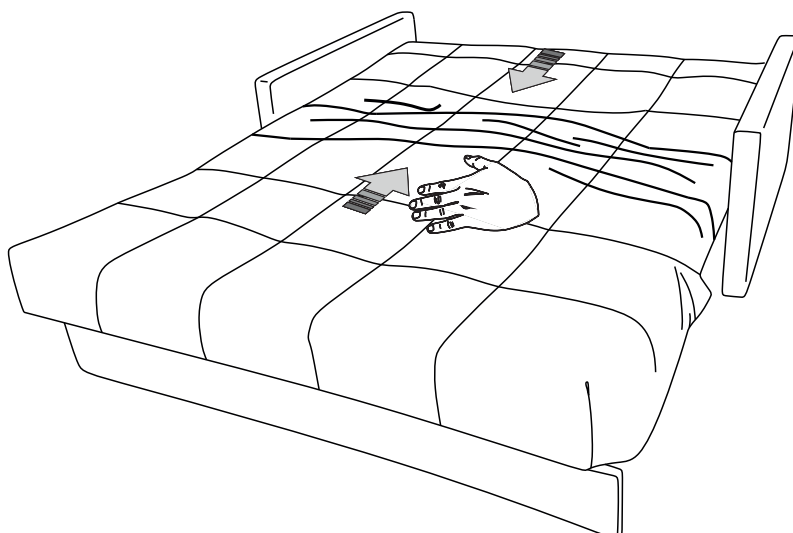

25)

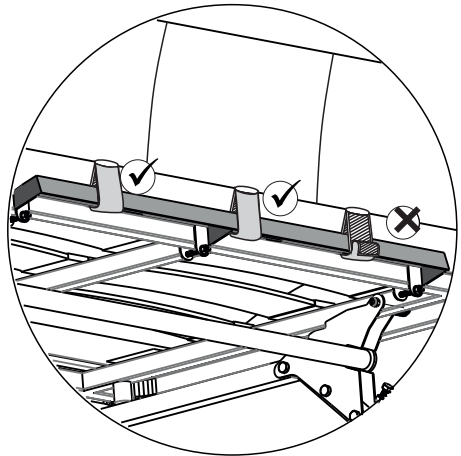
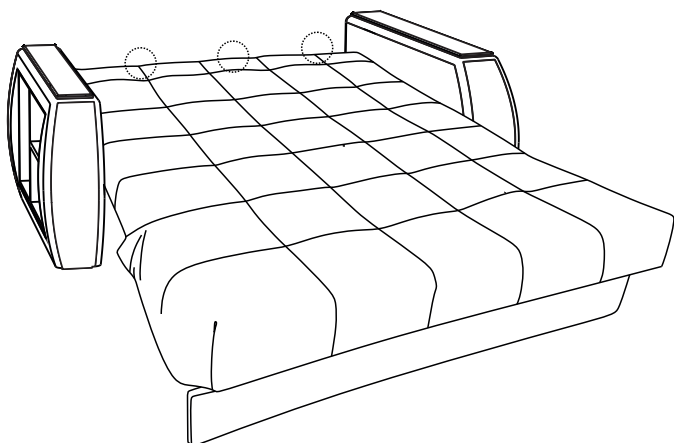

26)

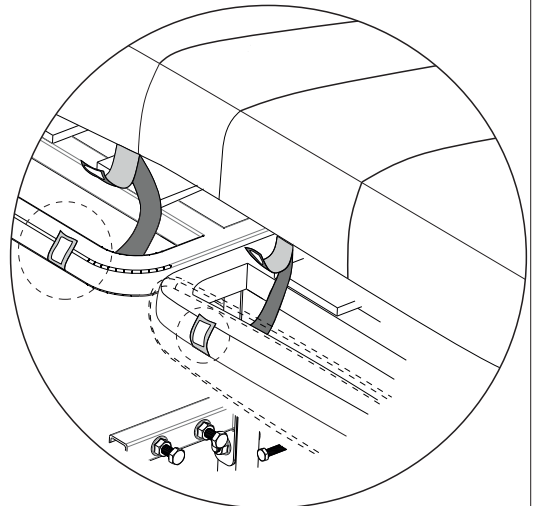
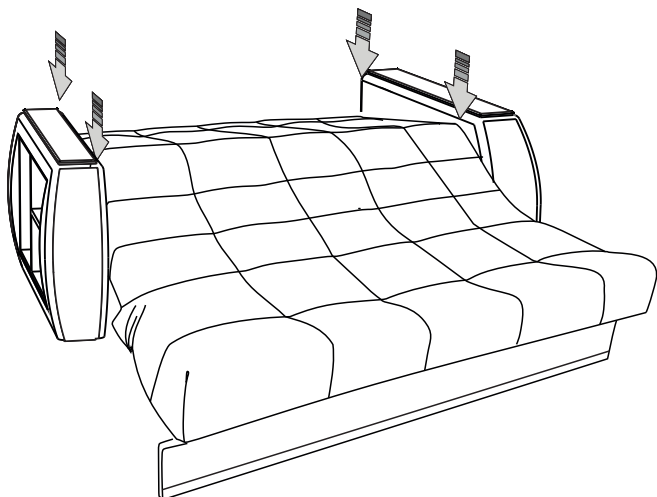

Move sofa to semi-unfolded position.  
When fixing, Velcros must be tightened as much as possible.

27)

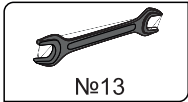
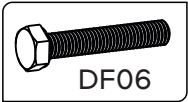
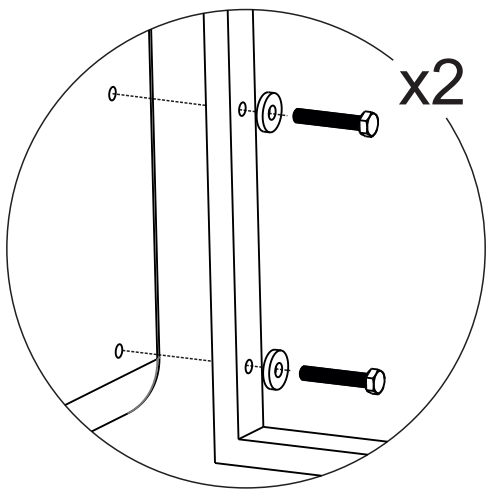
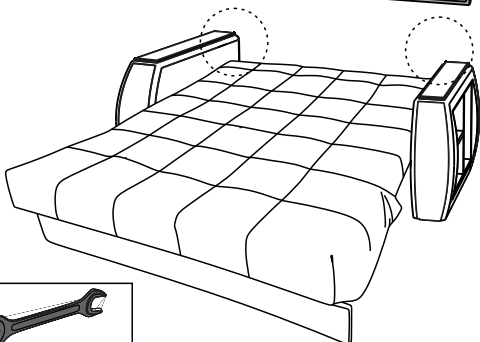
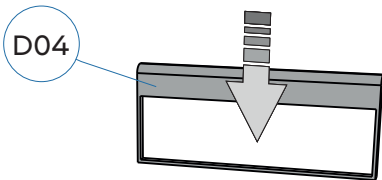

If there is a canape, go to the corner sofa assembly

28)

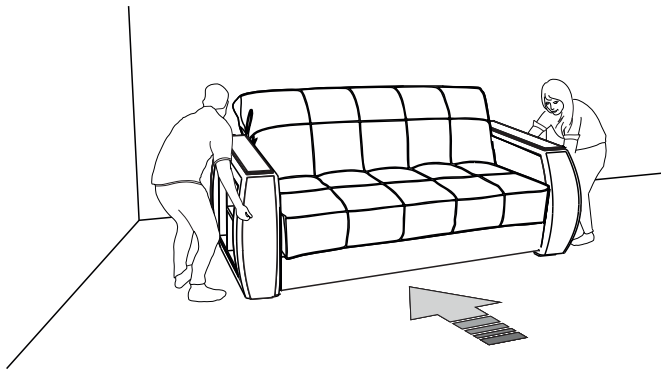

$A \approx B$  <sup>OK</sup> 

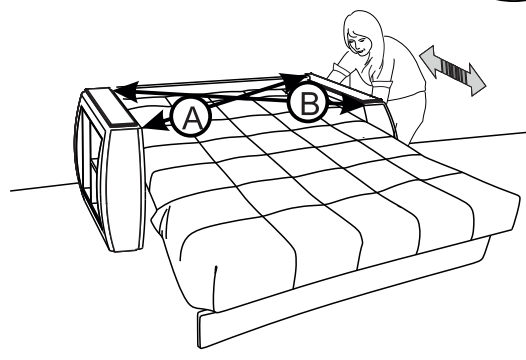

Install sofa into the place of permanent use

29)

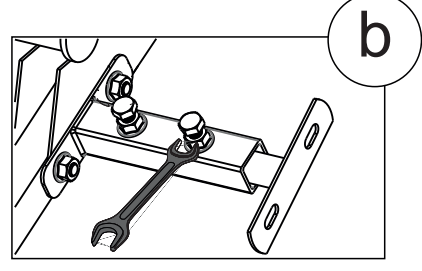
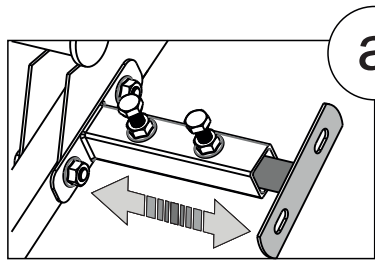
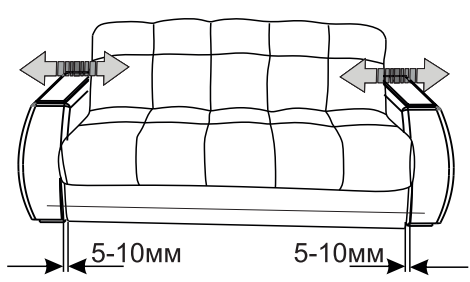

Tighten!

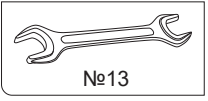

30)

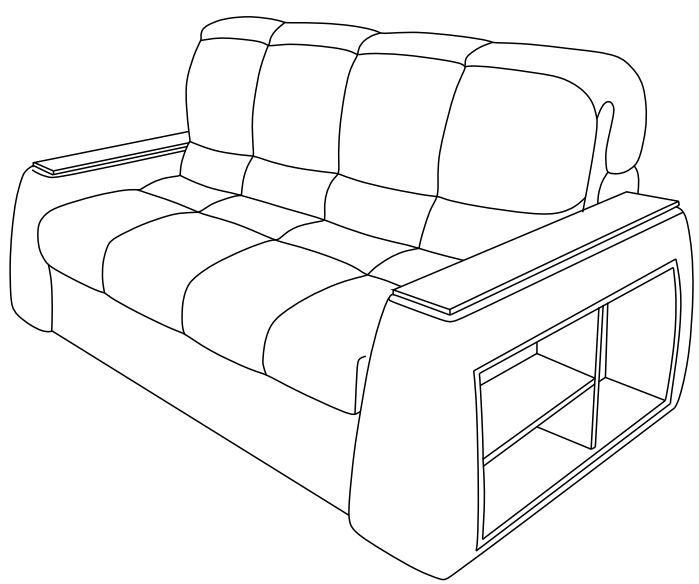

## Assembling the corner sofa

31)

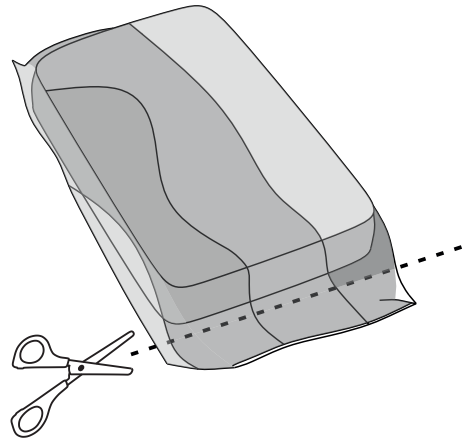
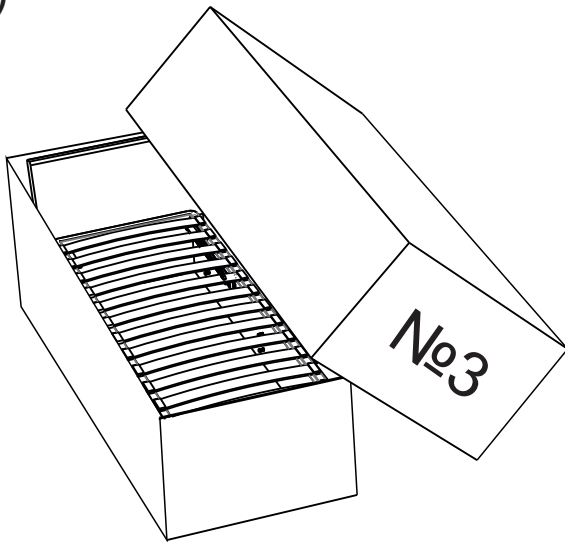

32

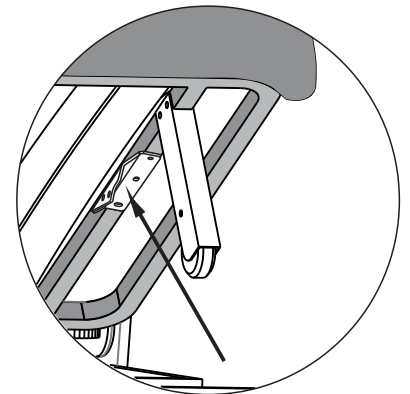
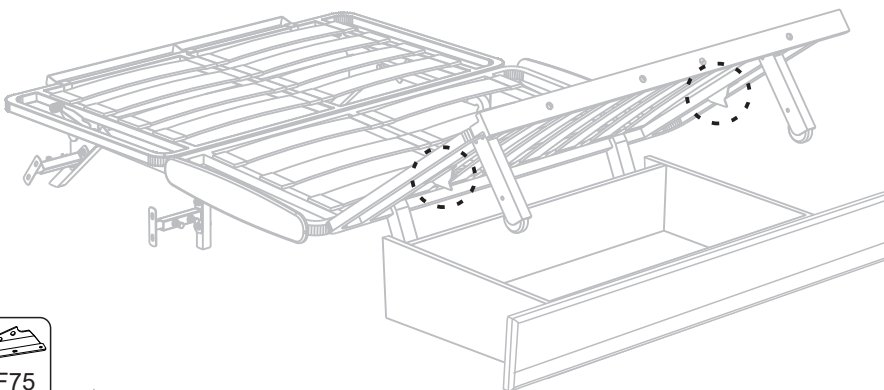

33)

Springs are installed only on a small canape

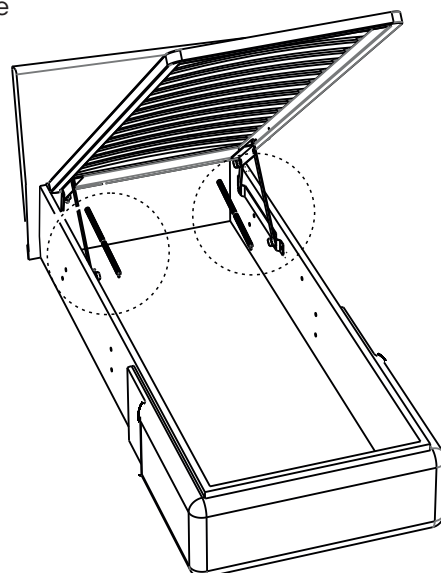
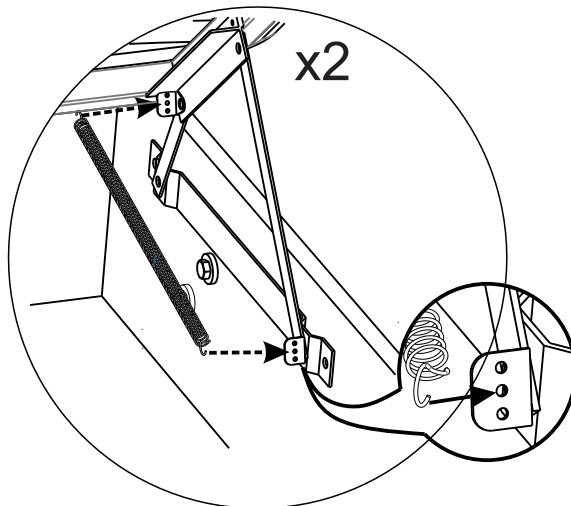



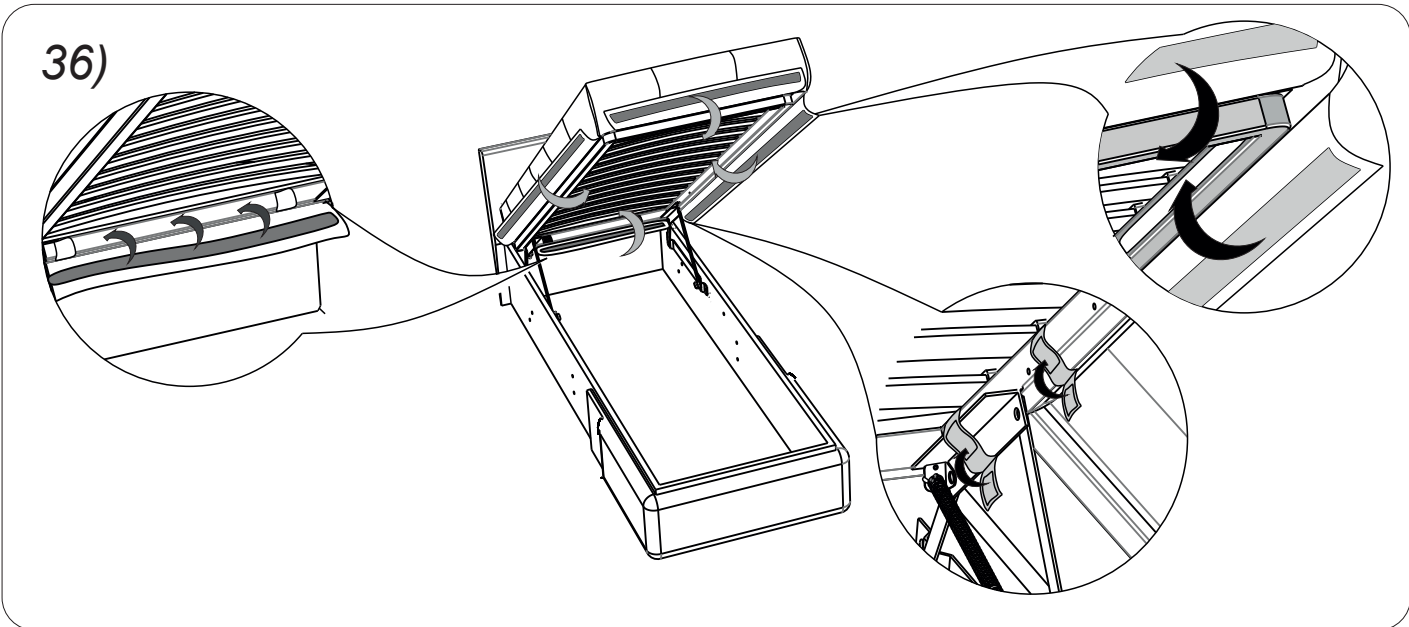
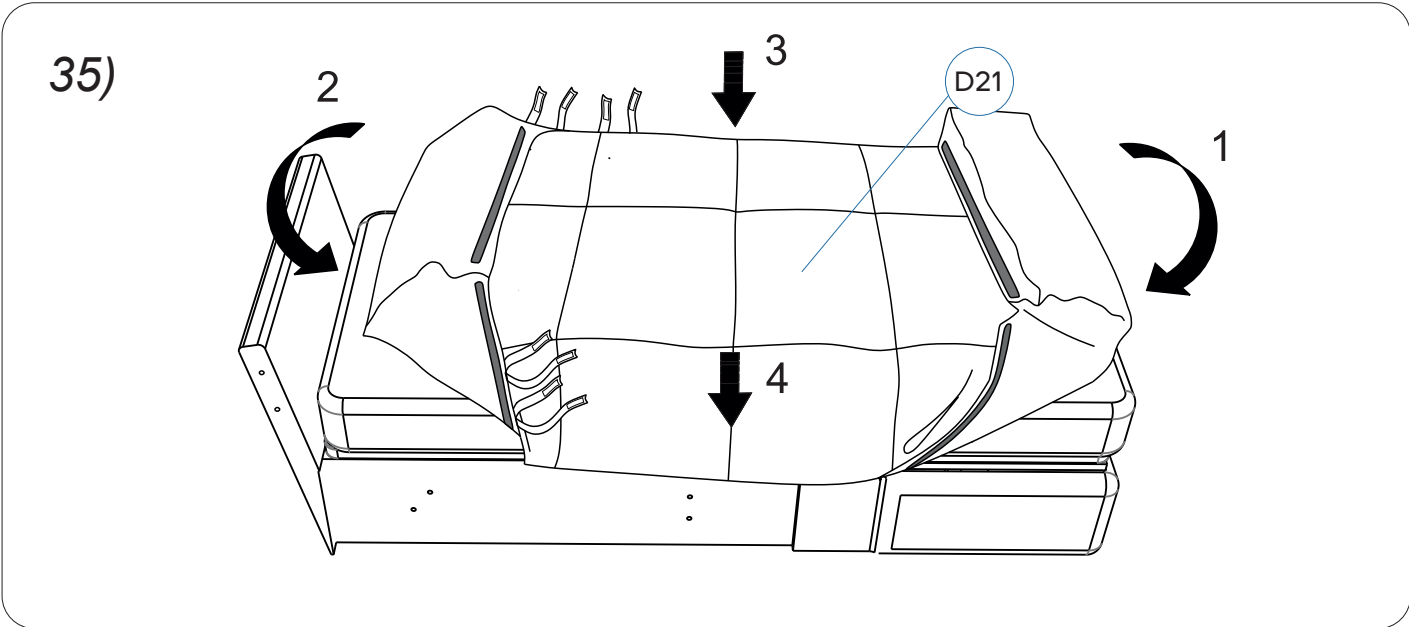
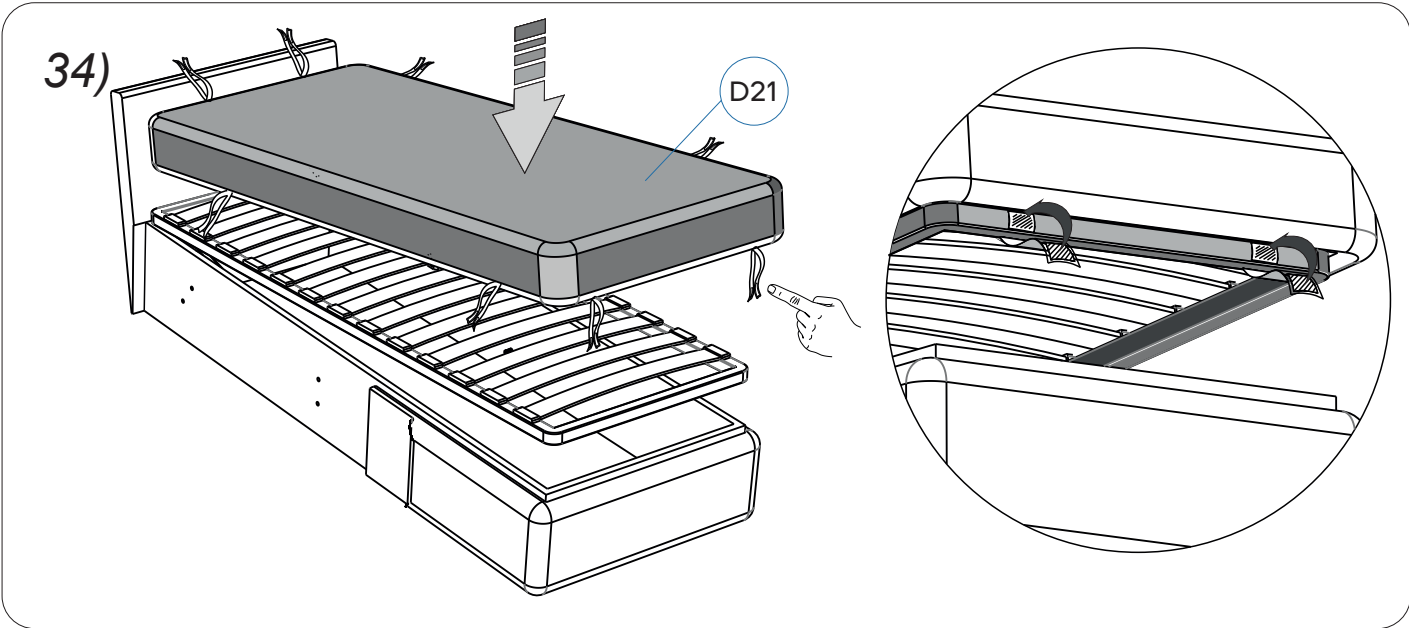

37)

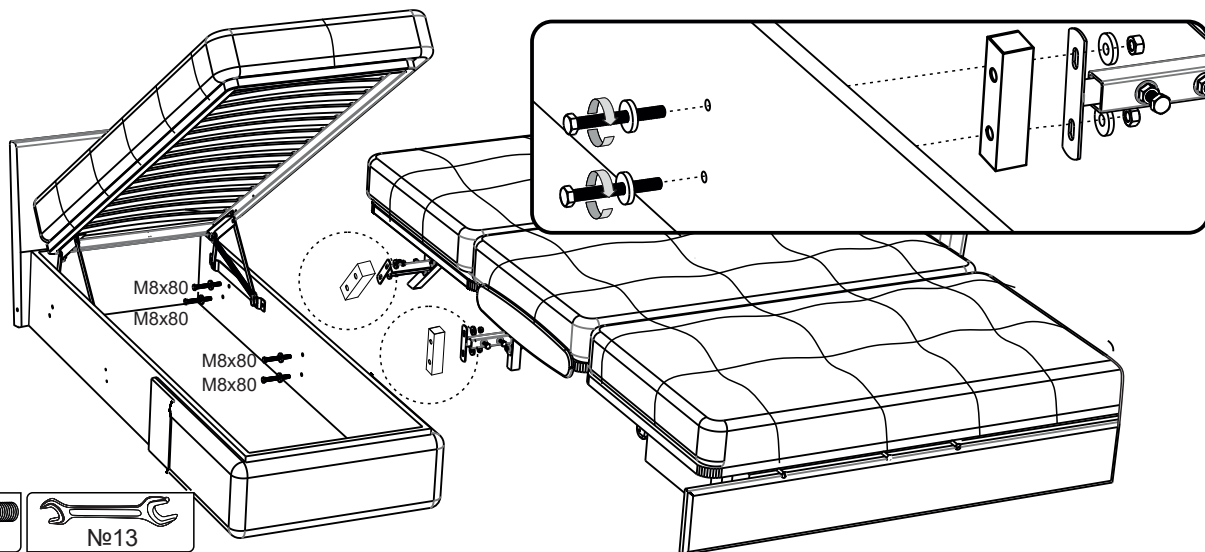

38)

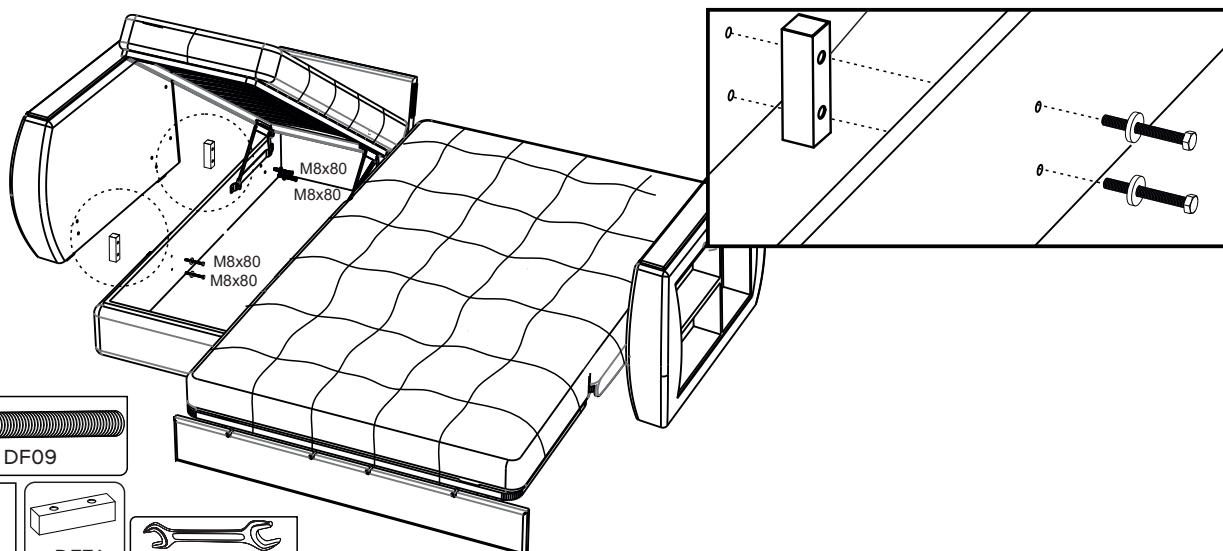
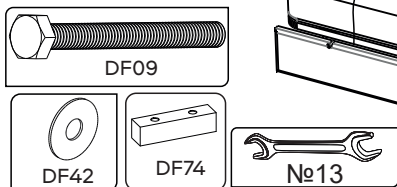

39)

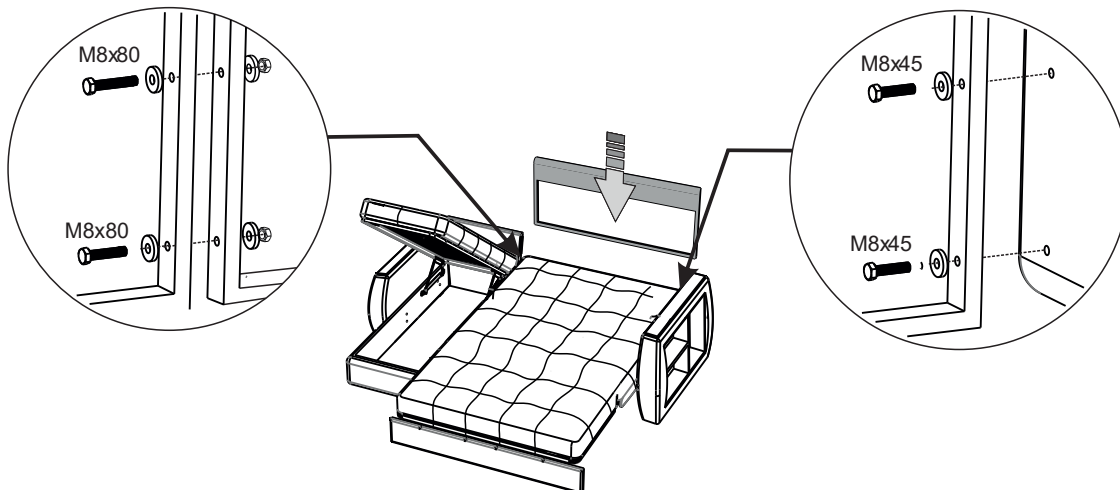



40)

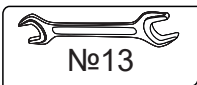
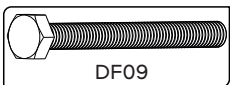
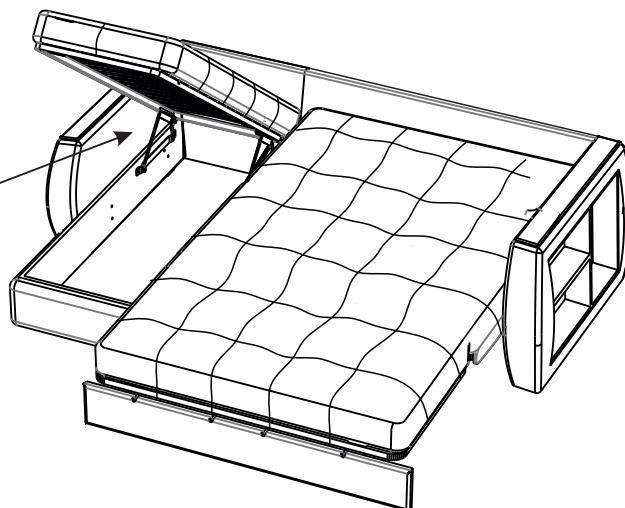
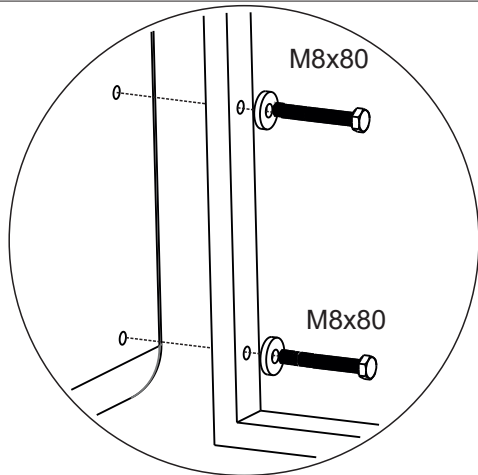

41)

1

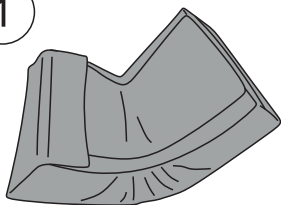

2

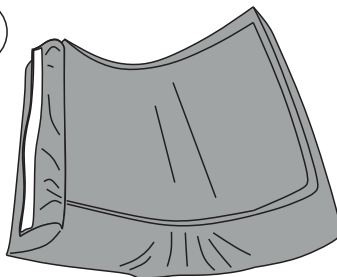

3

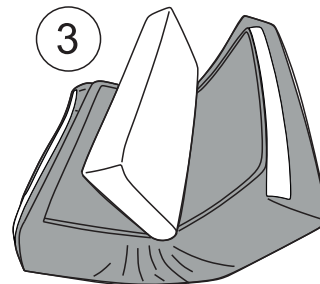

4

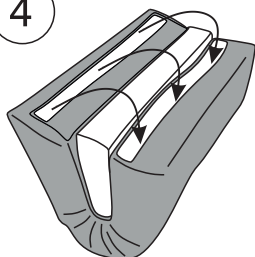

5

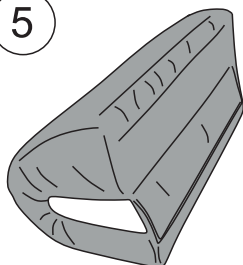

6

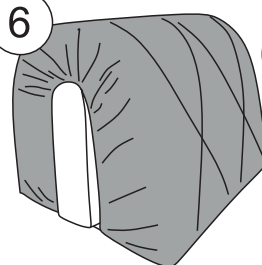

42)

b

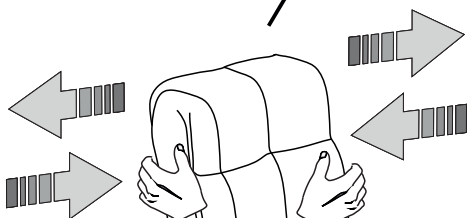

a

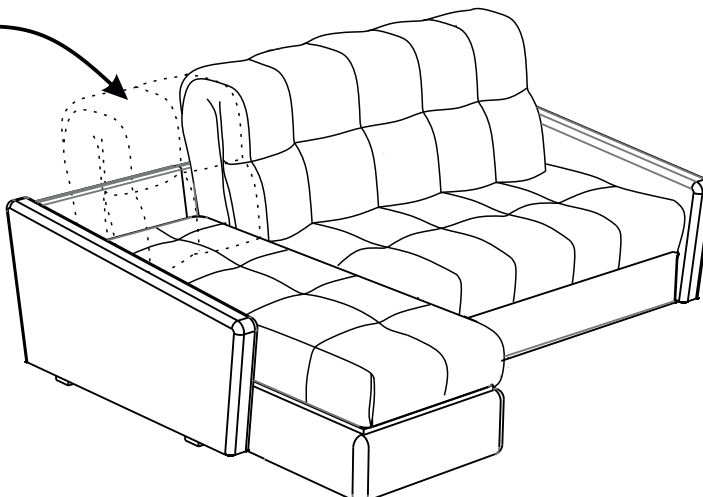

43)

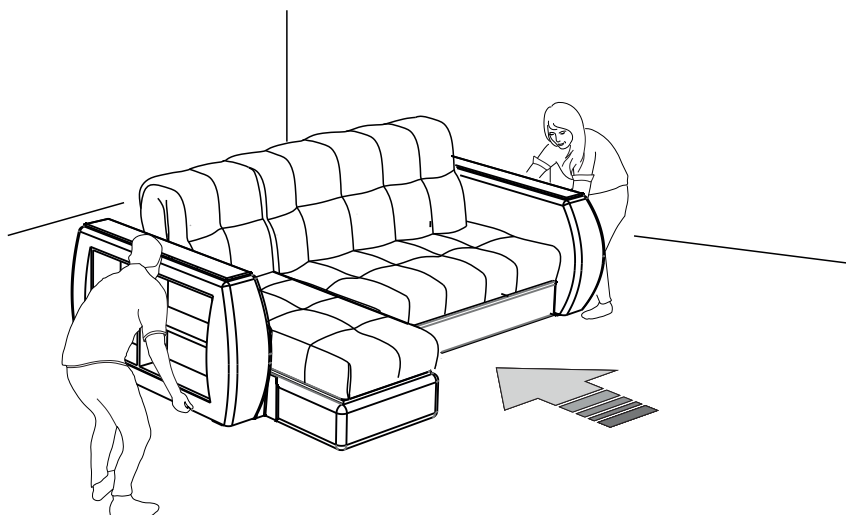

Install sofa into the place of permanent use

44)

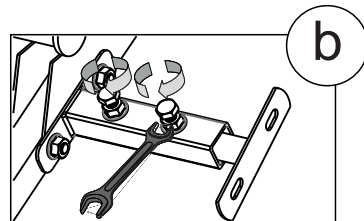
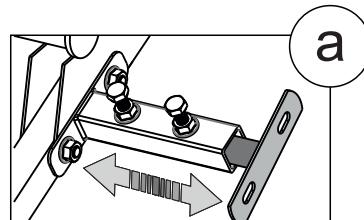
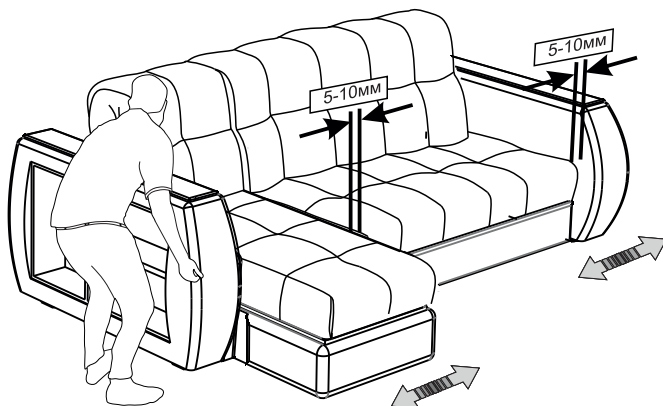

Tighten!



45)

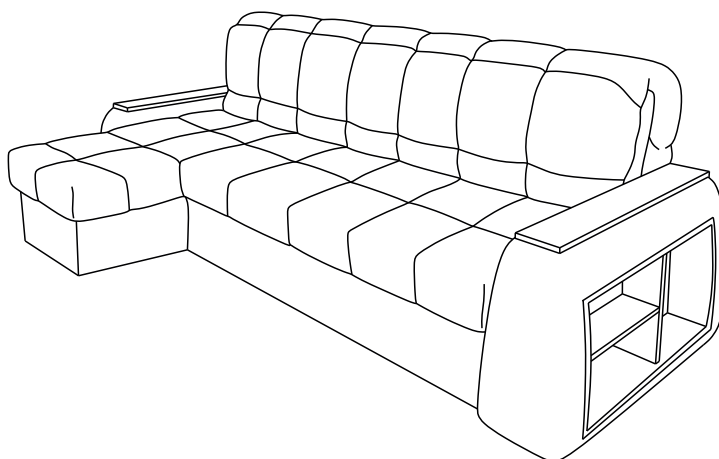

El procedimiento de transformación del sofá

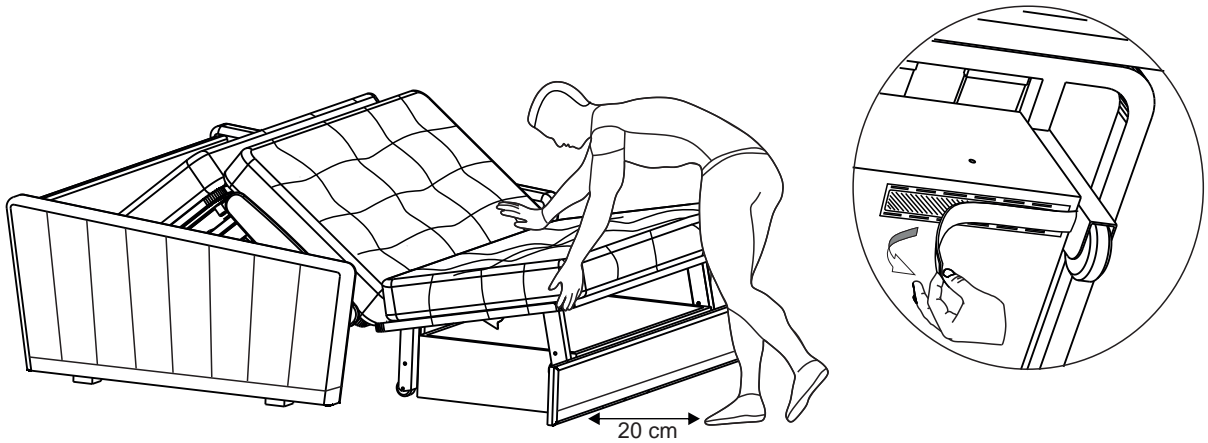
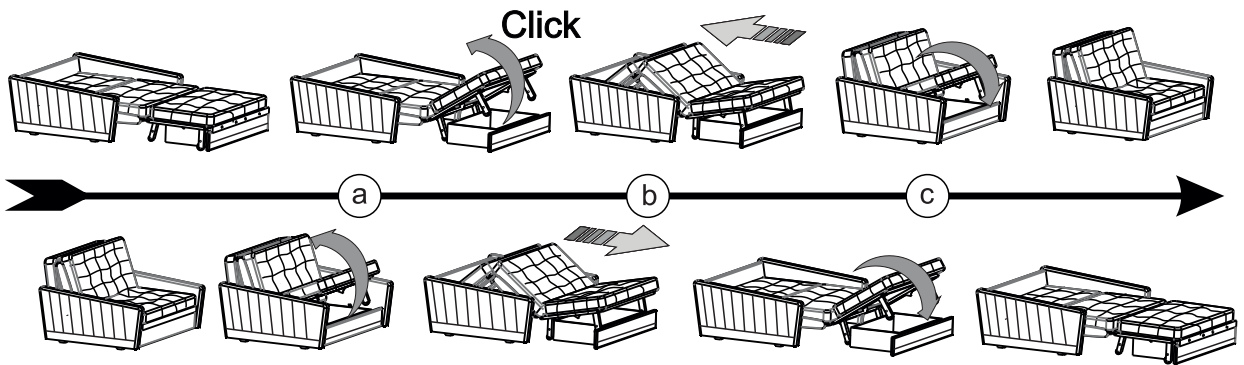

Si el asiento del sofá no se eleva, desabroche el velcro de envío.

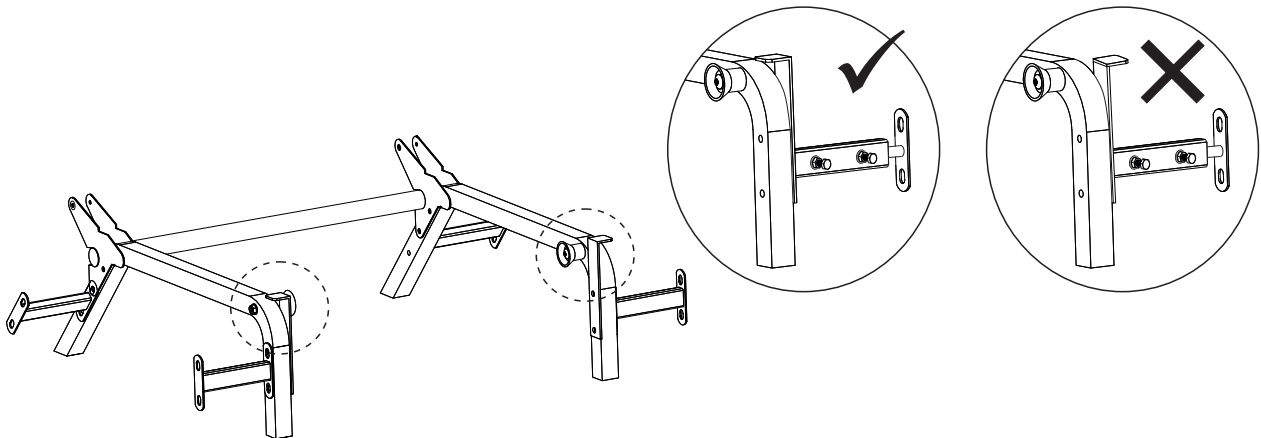

Si el asiento del sofá no se retrae, verifique la posición de los soportes en el mecanismo

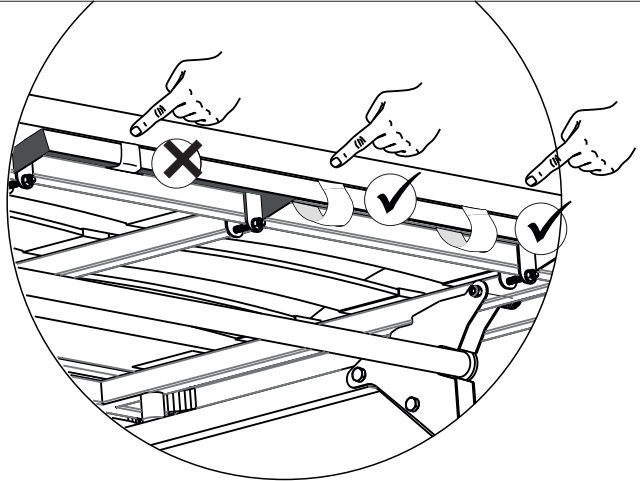
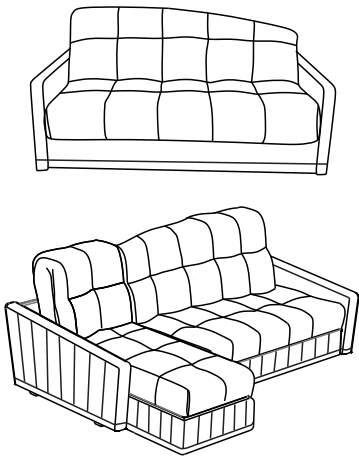

Si el respaldo está inclinado, afloje las cintas de contacto en la cabecera.

Si hay un espacio grande entre el colchón y el reposabrazos, levante el área del asiento y afloje las cintas de contacto.

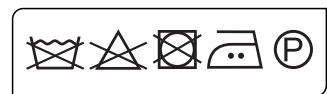
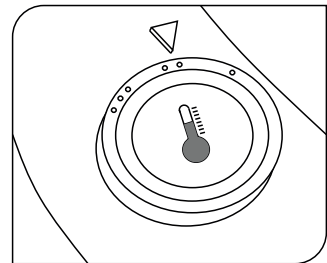
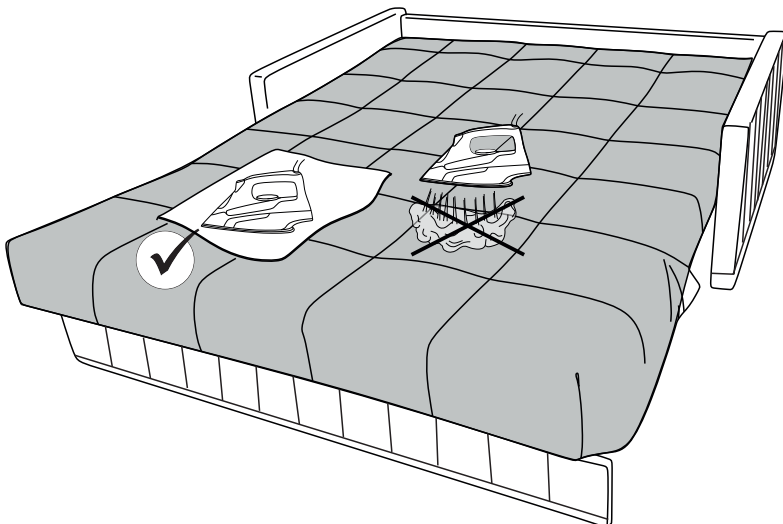
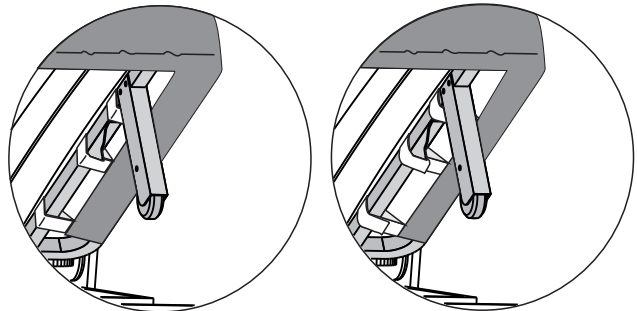
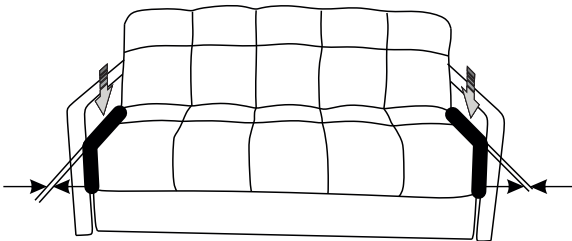
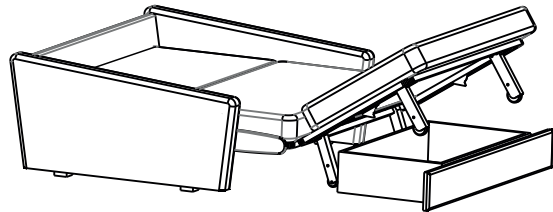

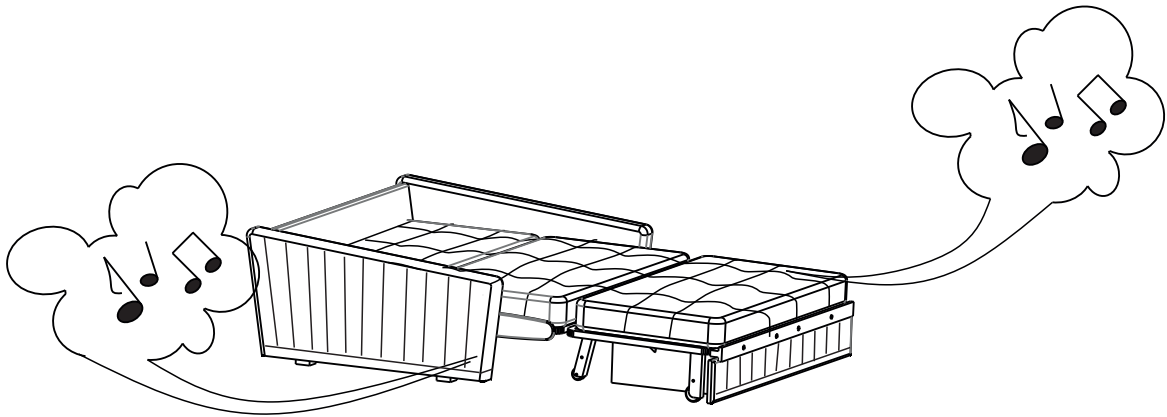

Recuerde: el chirrido característico de las partes metálicas del mecanismo durante la transformación constante es normal. En el corazón del sofá se encuentra una robusta estructura de metal que se puede transformar en una cama todos los días. Durante la transformación y el funcionamiento, la grasa entre las diferentes partes del mecanismo puede secarse y aparece la fricción de los elementos metálicos entre sí. Para evitar la ocurrencia de la fricción y el chirrido del mecanismo durante la transformación o el funcionamiento, es importante seguir las siguientes recomendaciones.

Si el mecanismo chirría, los elementos de fricción deben lubricarse. Tira las conexiones.  
Lubricar al menos una vez cada 6 meses.

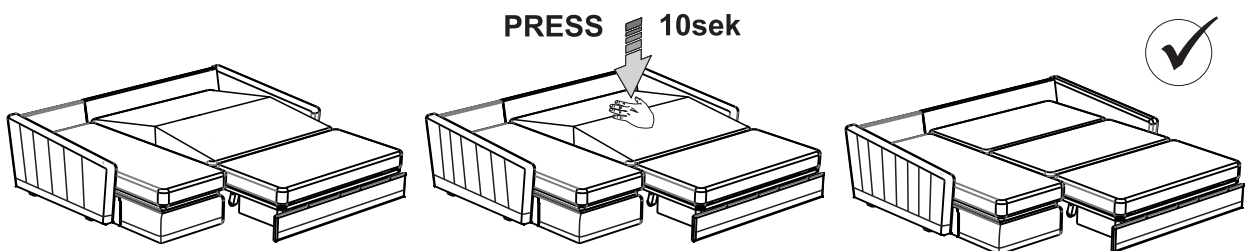
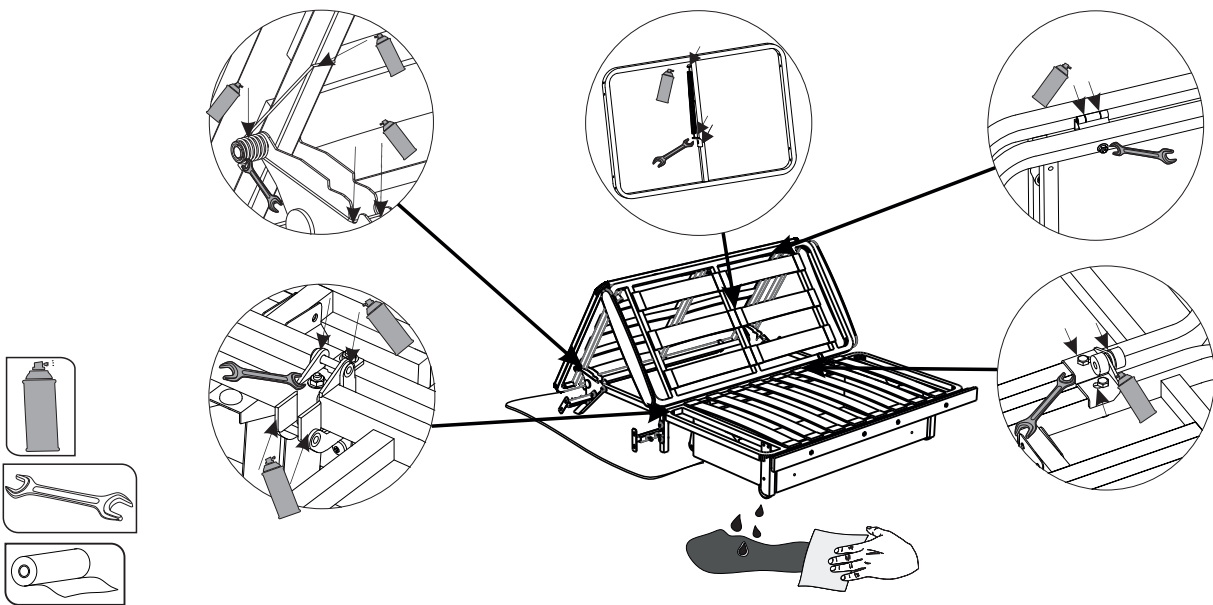

Mantener presionado durante 10 segundos

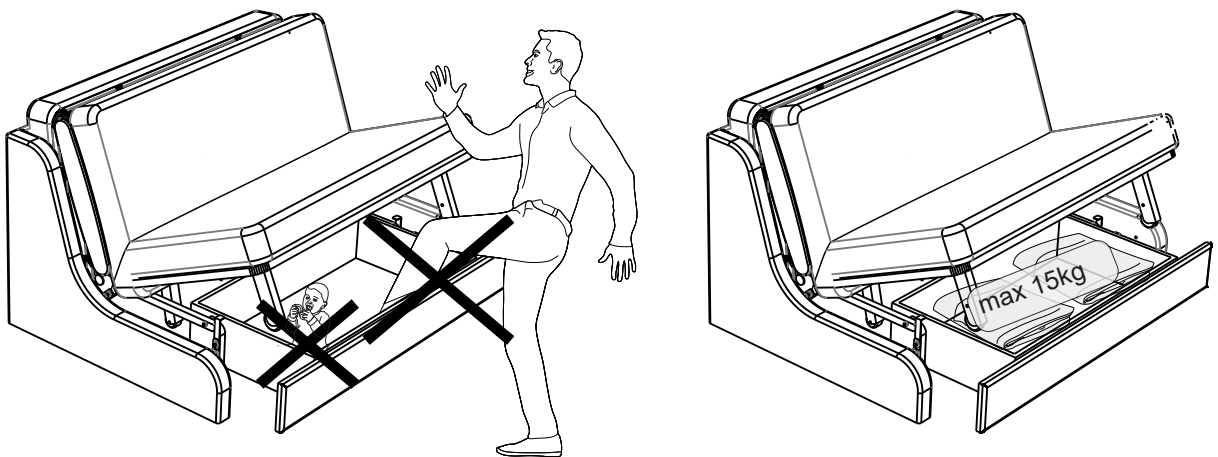
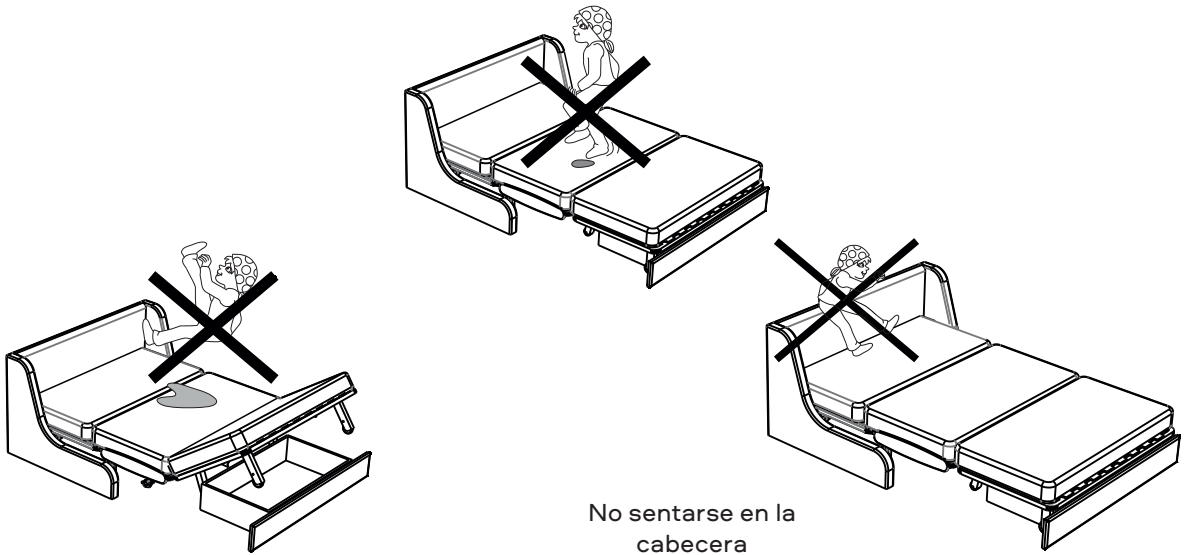
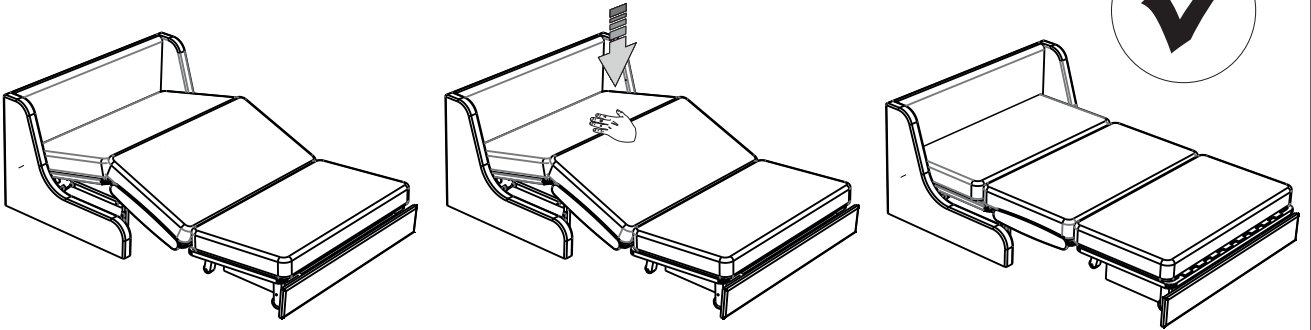

# SUNSET NOVA



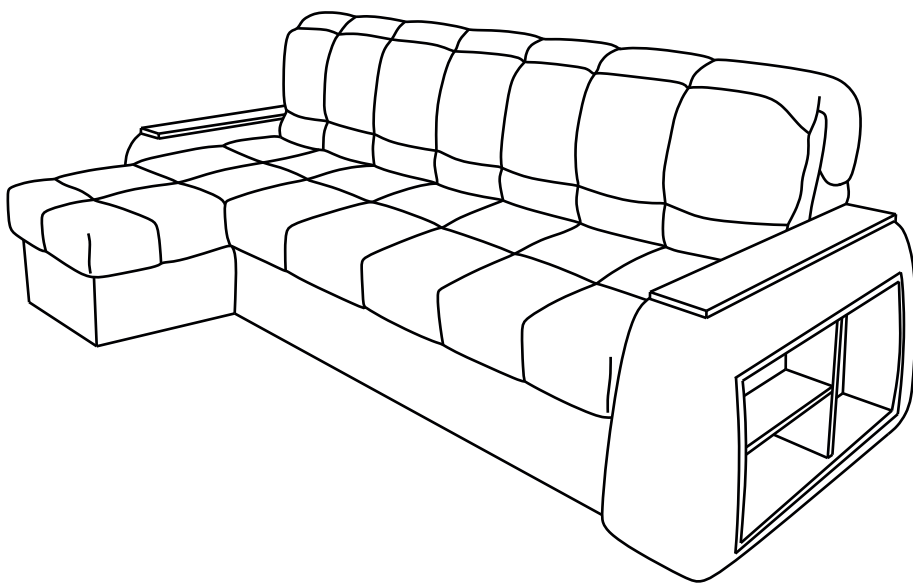
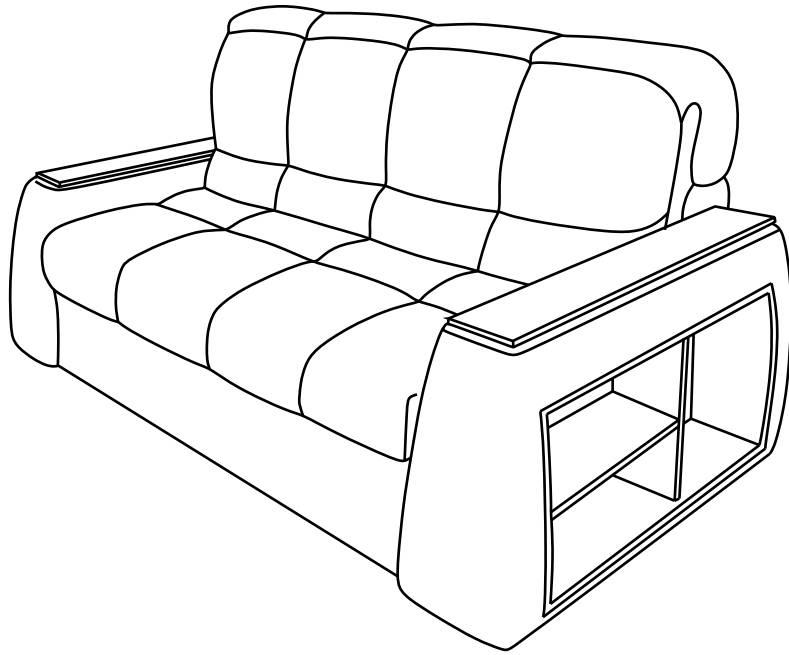





ES



Sleep.8

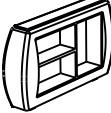
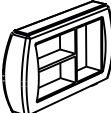
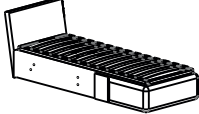



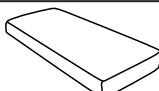

### Equipo estándar del sofá



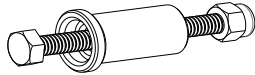
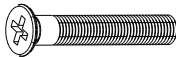

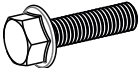
Embalaje	Pieza	Artículo	Denominación	Cantidad
Nº 1		D01	Mecanismo de transformación	1
		D26	Soporte del mecanismo de transformación	1
		D04	Respaldo	1
		D05	Bastidor	1
		D07	Funda acolchada	1
			Paquete con herrajes	1
			Instrucciones para el ensamblaje, muestra del tejido	1
Nº 2		D06	Apoyabrazos	1
Nº 3		D06	Apoyabrazos	1
Nº 4 opción adicional al pedir el sofá con un canapé		D14	Canapé	1
		D11	Almohada-canapé	1
		D08	Funda del canapé, muestra del tejido de la funda	1
			Paquete con los herrajes para el canapé	1
			Instrucciones para el ensamblaje, muestra del tejido	1
No incluido Entreg separada		D20	Colchón	1
		D21	Colchón del canapé	1

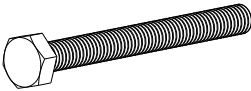

### Lista de herrajes del sofá

Embalaje	Pieza	Artículo	Denominación	Cantidad
Paquete con herrajes		DF02 DF15 DF16	Perno M6x65 Buje de plástico Tuerca M6 (autoblocante)	2
		DF11	Tornillo de cabeza embutida M6x30	3
		DF31	Resorte con ganchos	2
		DF06	Perno M8x45	4
		DF56	Perno M8x30	8
		DF42	Arandela M8	4



### Lista de herrajes del canapé

Embalaje	Pieza	Artículo	Denominación	Cantidad
Paquete con herrajes		DF30	Resorte en el canapé (sólo para un canapé pequeño)	2
		DF09	Perno M8x80	10
		DF19	Tuerca M8	6
		DF42	Arandela M8	14
		DF74	Placa separadora para el canapé	4
		DF75	Parada del mecanismo	2

**Antes del montaje:**

- 1) ¡Compruebe el aspecto y la integridad de las piezas de la caja!** Las reclamaciones por daños solo se aceptan si los productos NO tienen rastros de montaje visibles.
- 2) ¡No deseche el embalaje y este manual hasta que se complete el montaje!** En caso de detección en el proceso de montaje de piezas defectuosas y no conformidad del producto, es necesario conservar el embalaje hasta que se visite al representante de la empresa comercial.
- 3) Compare las piezas y los accesorios con la lista antes de comenzar el montaje.** El fabricante se reserva el derecho de realizar cambios en el diseño del producto, reemplazar accesorios y hardware, reemplazar con análogos, que no alteren las propiedades funcionales del producto. En ausencia o falla de cualquier detalle, encierre en un círculo el número de pieza e informe a la tienda.
- 4) ¡Observe el orden de montaje especificado en las instrucciones!** En caso de incumplimiento de las instrucciones de montaje y funcionamiento, el fabricante renuncia a todas las obligaciones de la garantía.
- 5) Para instalar el sofá cama, elija un suelo plano.** Las curvas del suelo y las alfombras gruesas pueden provocar desviaciones en el funcionamiento del mecanismo de transformación del sofá cama y distorsión de la forma del producto.
- 6) Arme el sofá cama con la ayuda de alguien.** ¡Mueva todas las piezas con cuidado, sin golpes, colóquelas de forma segura, ¡no se caigan ni golpeen!
- 7) Mueva el mueble y sus partes, levantándose ligeramente, para evitar deformaciones y roturas.**
- 8) ¡Durante el montaje, lubrique el mecanismo de elevación de acuerdo con las instrucciones!** Esto ayudará a prevenir un chirrido. Lubrique y apriete los tornillos y tuercas sueltos al menos una vez durante seis meses.

**Para montar ustedes necesitan:**

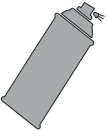
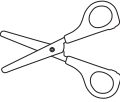
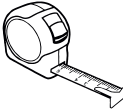
	<p>Destornillador punta cruzada</p>
	<p>Llave fija Nº13 x 1 Llave fijar Nº10 x 2</p>
	<p>Toalla de papel</p>
	<p>Spray-grasa de silicona</p>
	<p>Tijeras</p>
	<p>Cinta métrica</p>

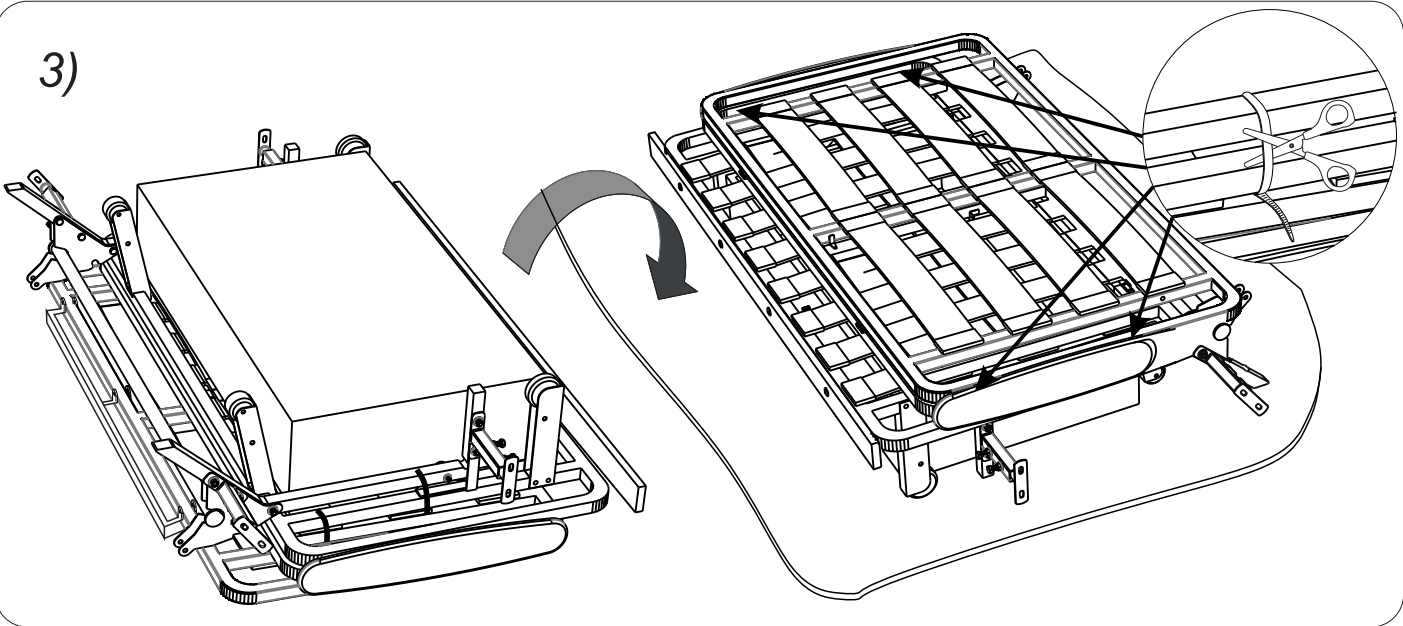
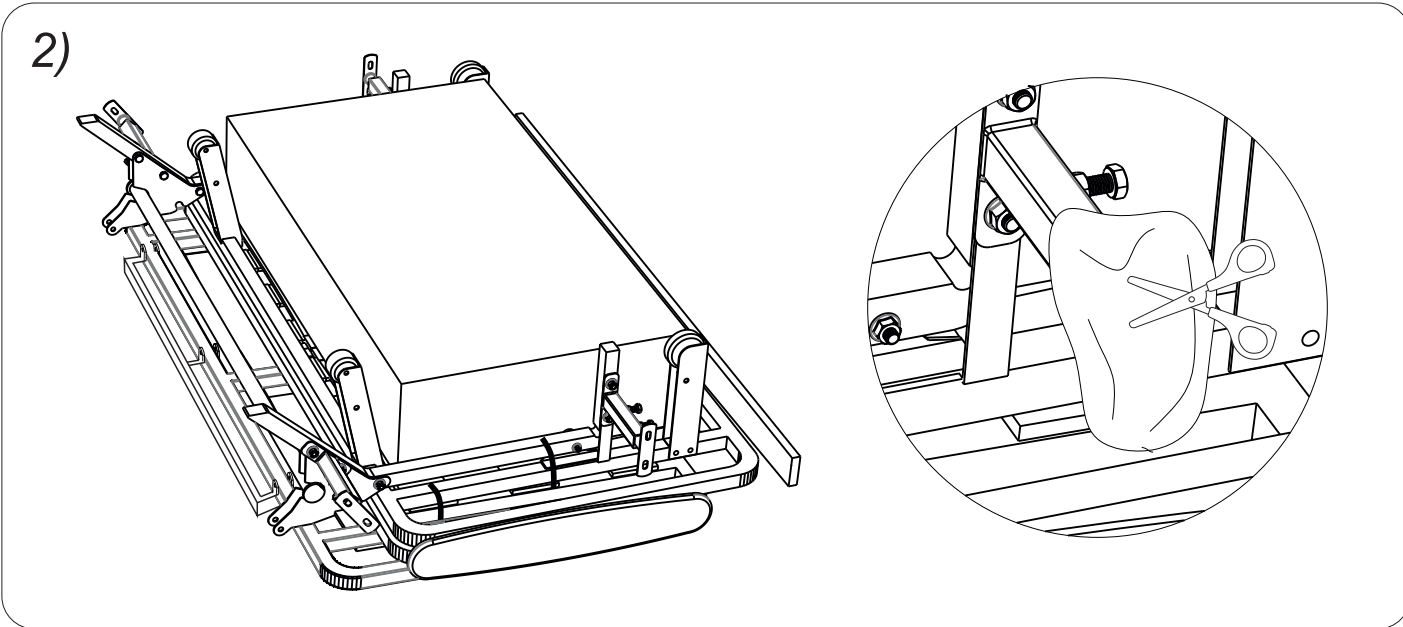
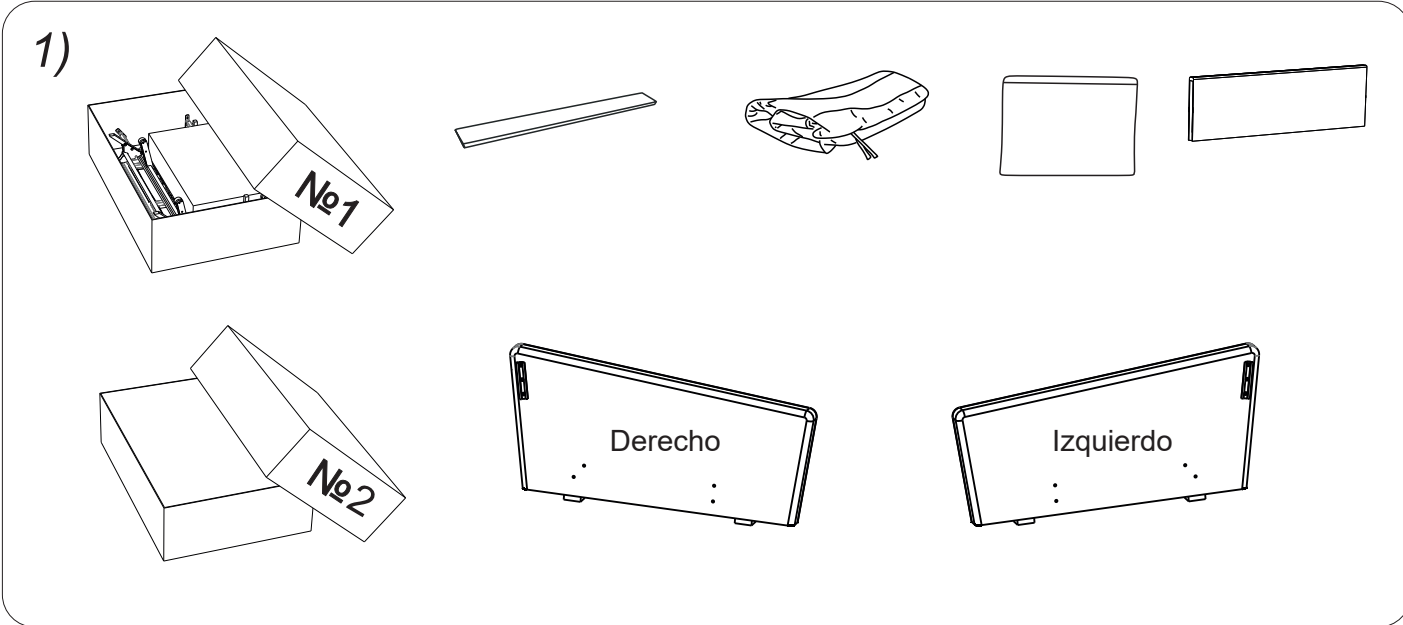

4)

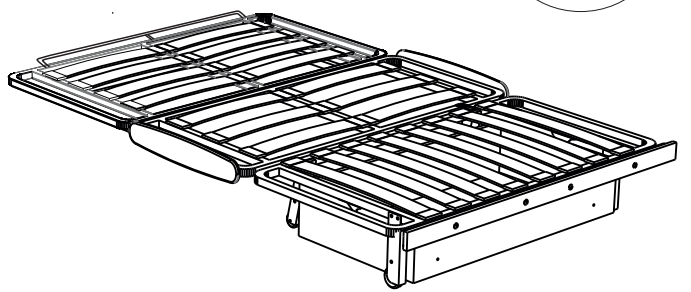
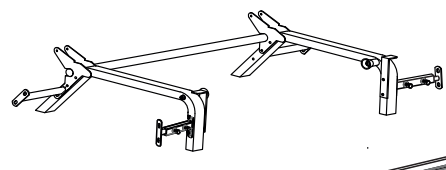
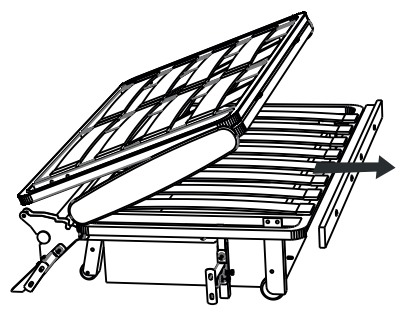

Retírese el marco de la base

5)

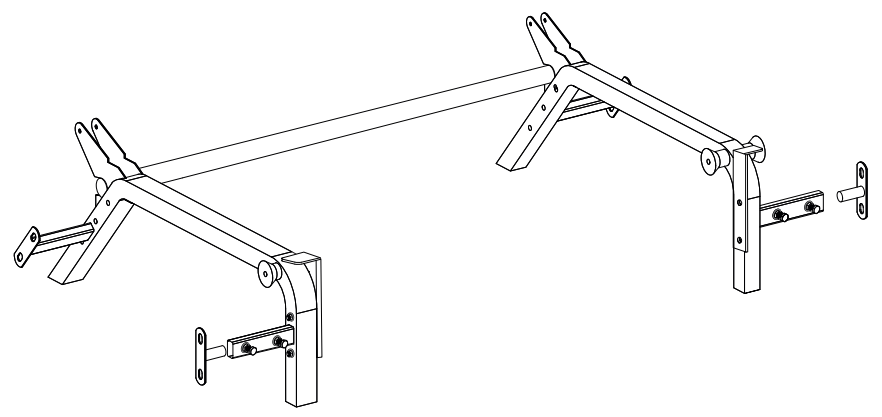
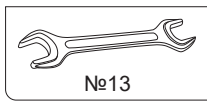
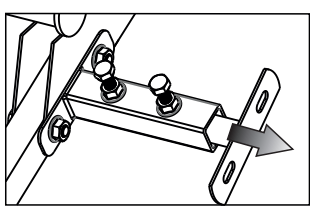
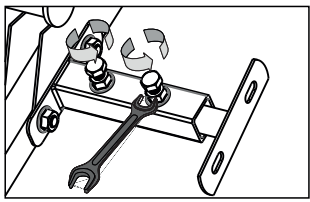

6)

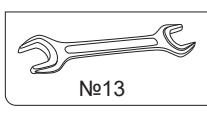
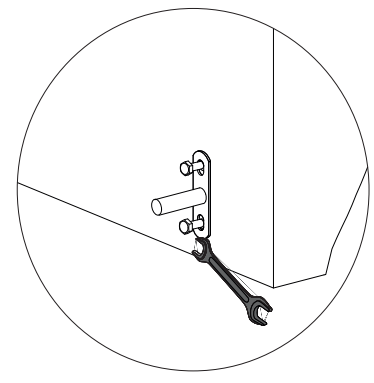
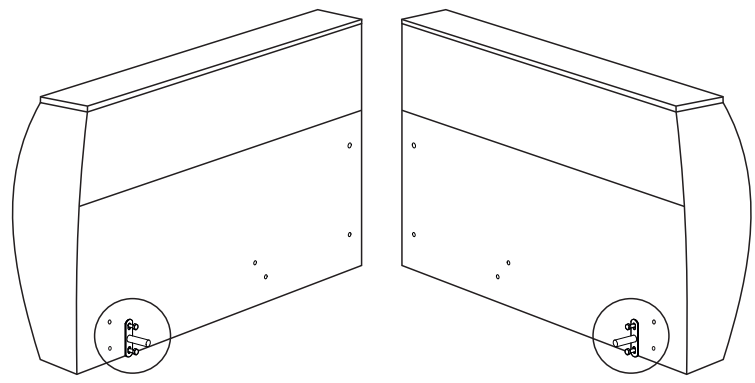

Al ensamblar un sofá rinconera, coloque el soporte en un apoyabrazos (en el lado opuesto al canapé)

7)

No apriete los pernos de los soportes

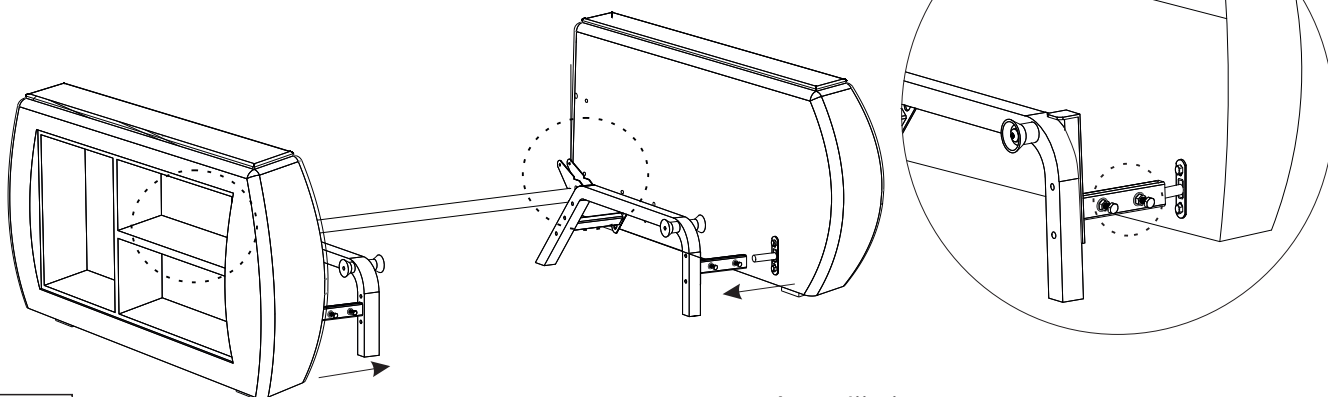

Atornille los soportes traseros.  
No apriete los pernos de los soportes delanteros.

8)

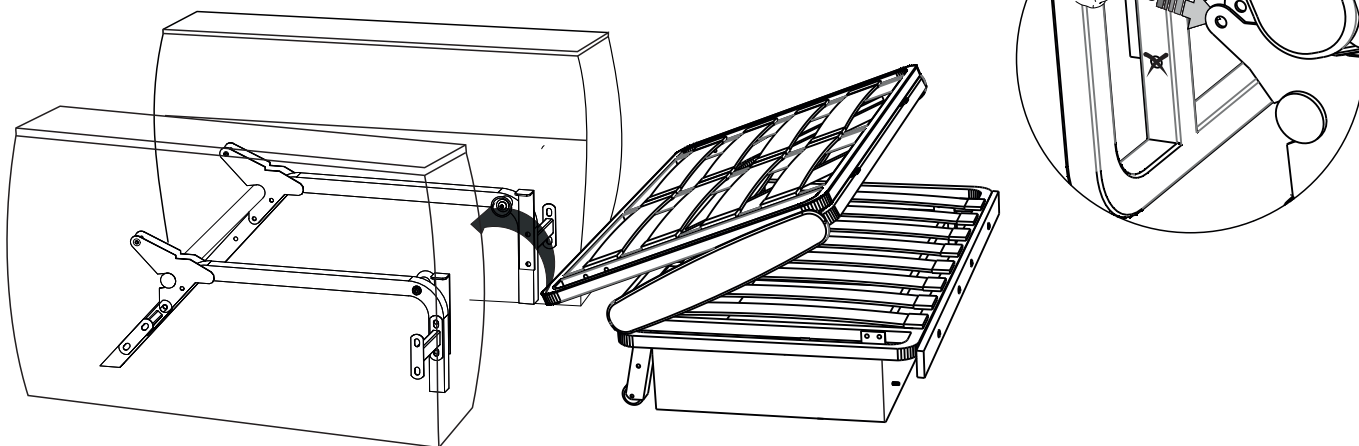

No lo apriete mucho

9)

x2

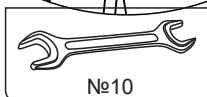
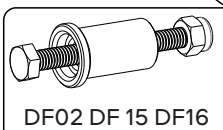
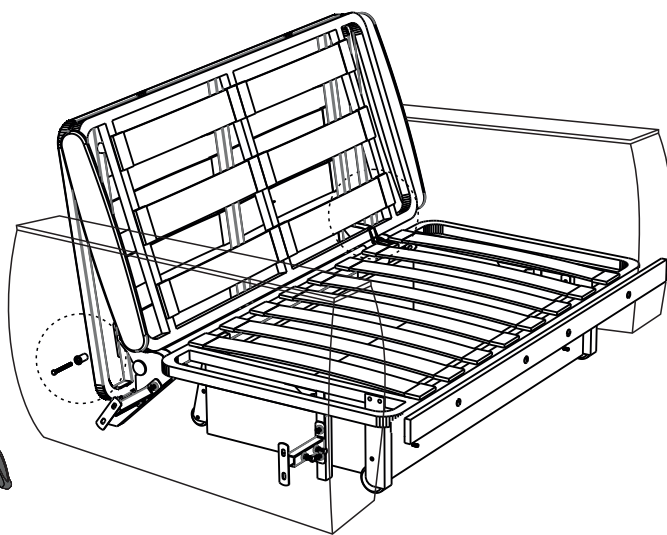
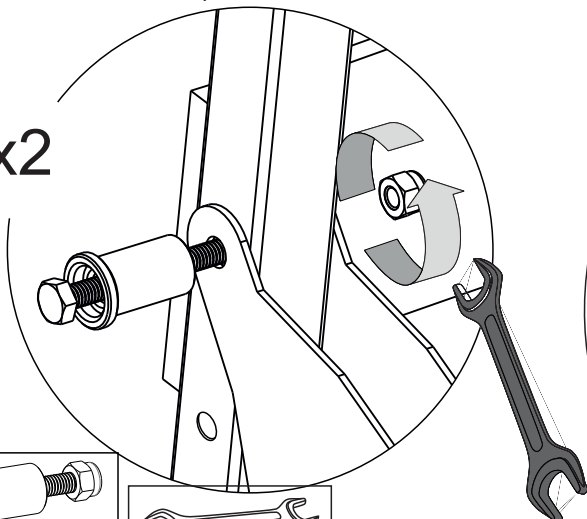

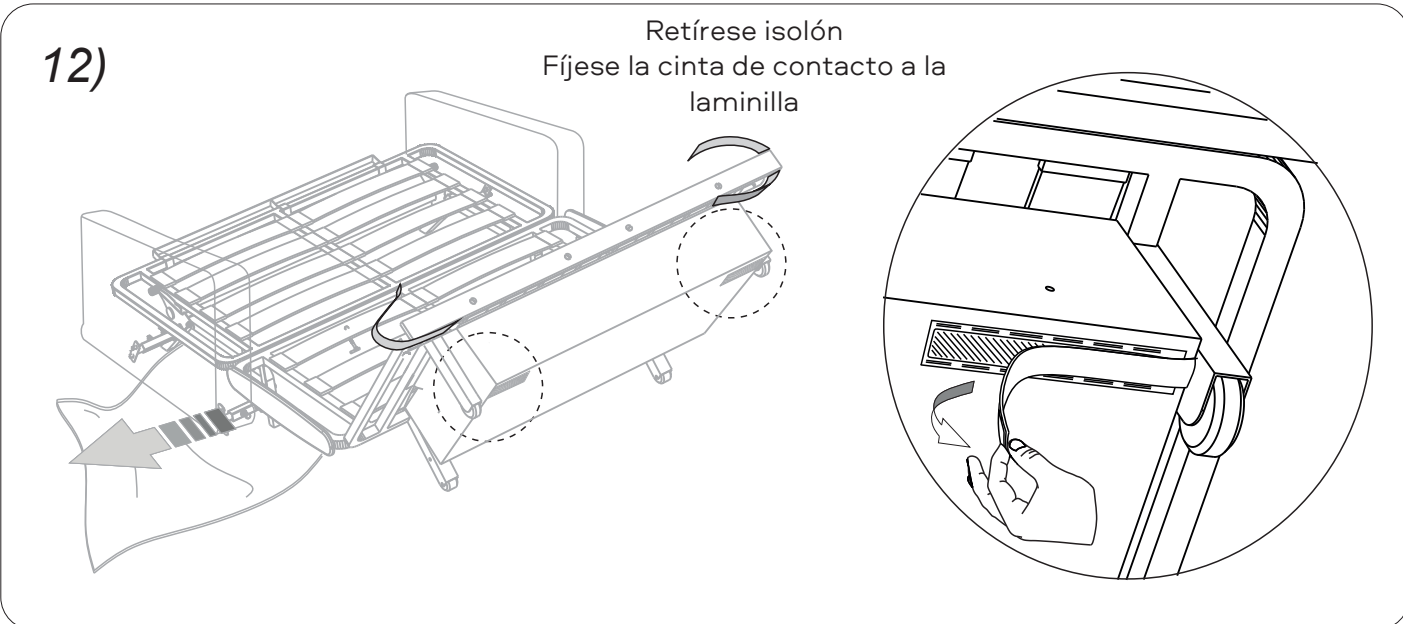
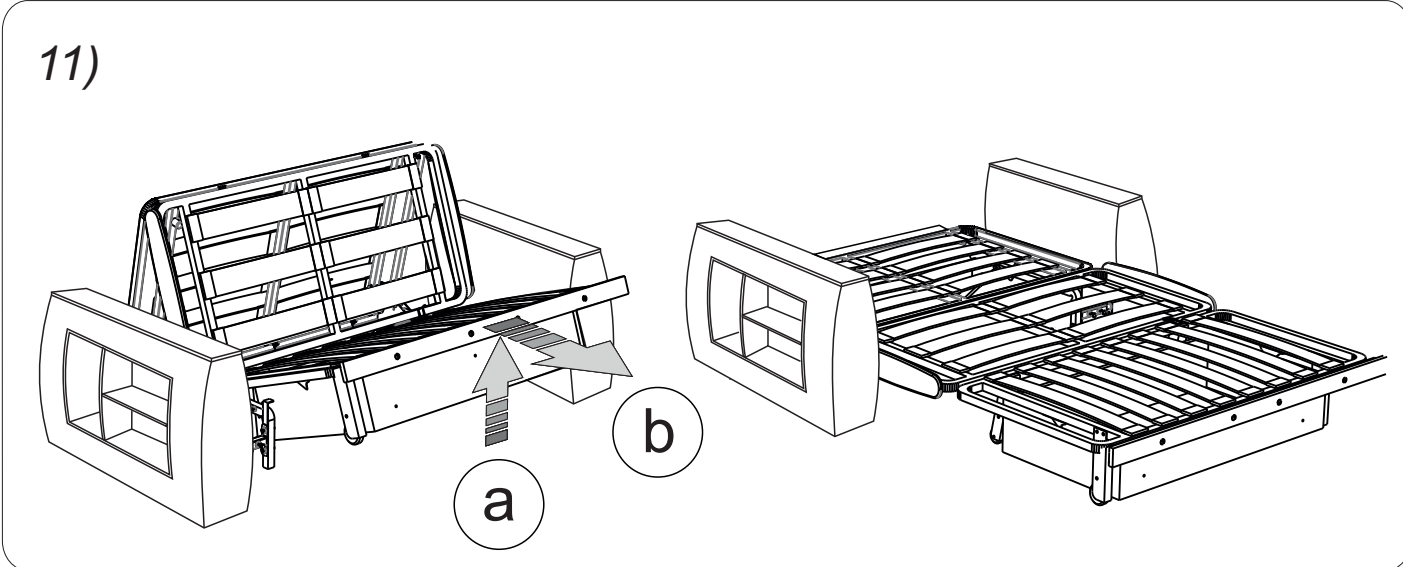
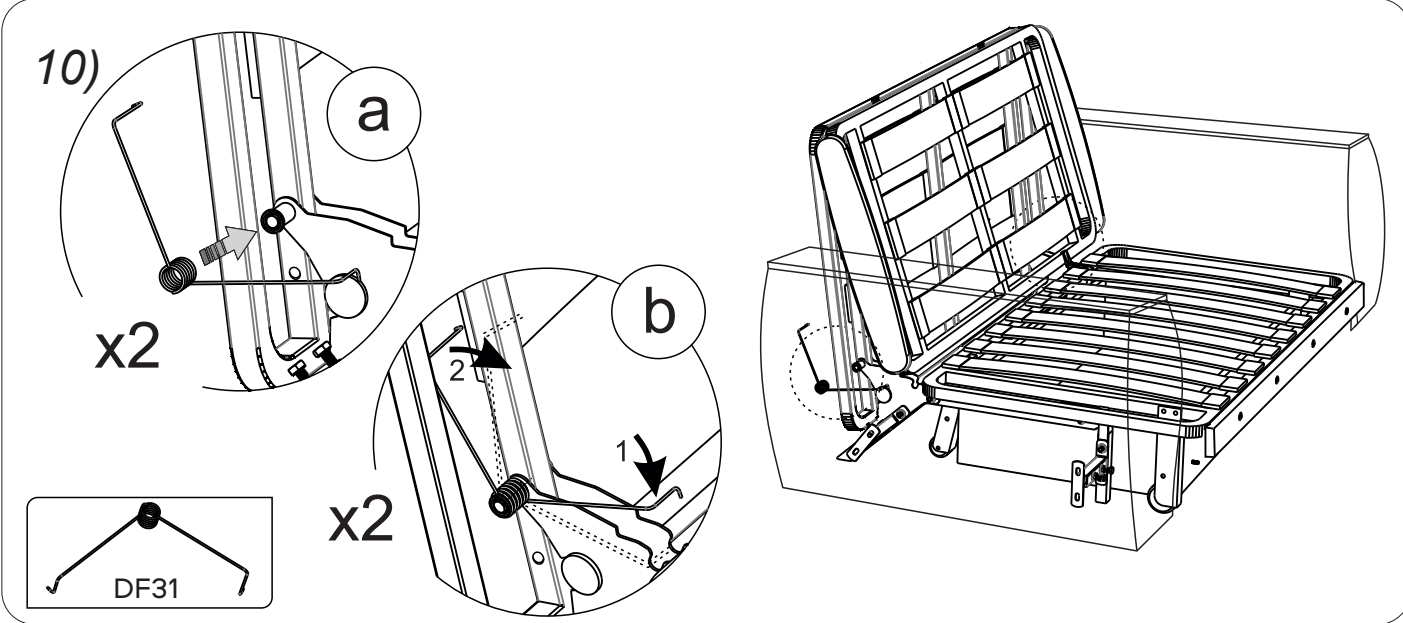



13)

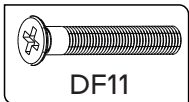
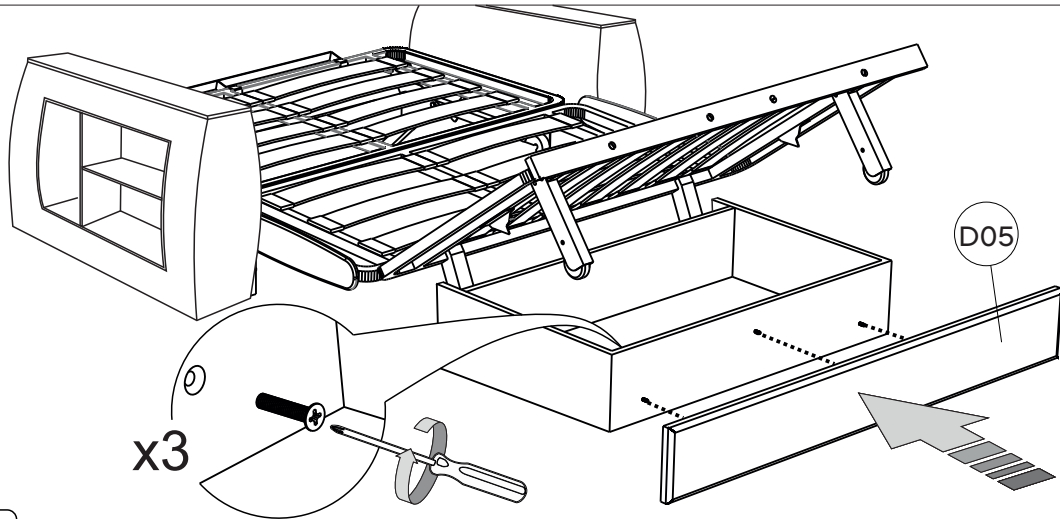

La parte inferior del bastidor se determina por la presencia de una banda de grapas

14)

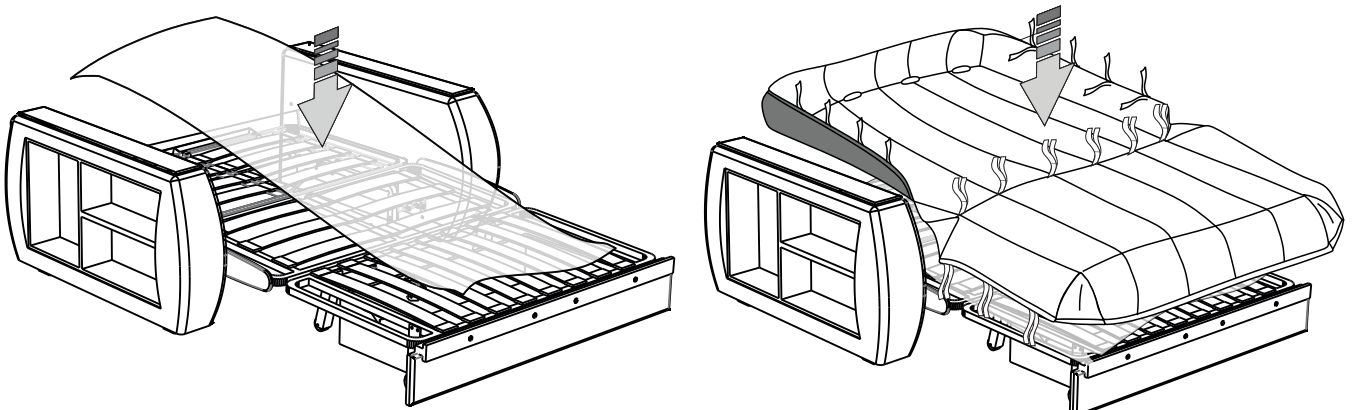

Colóquese la película del embalaje del sofá sobre el mecanismo para proteger la funda contra la grasa.

15)

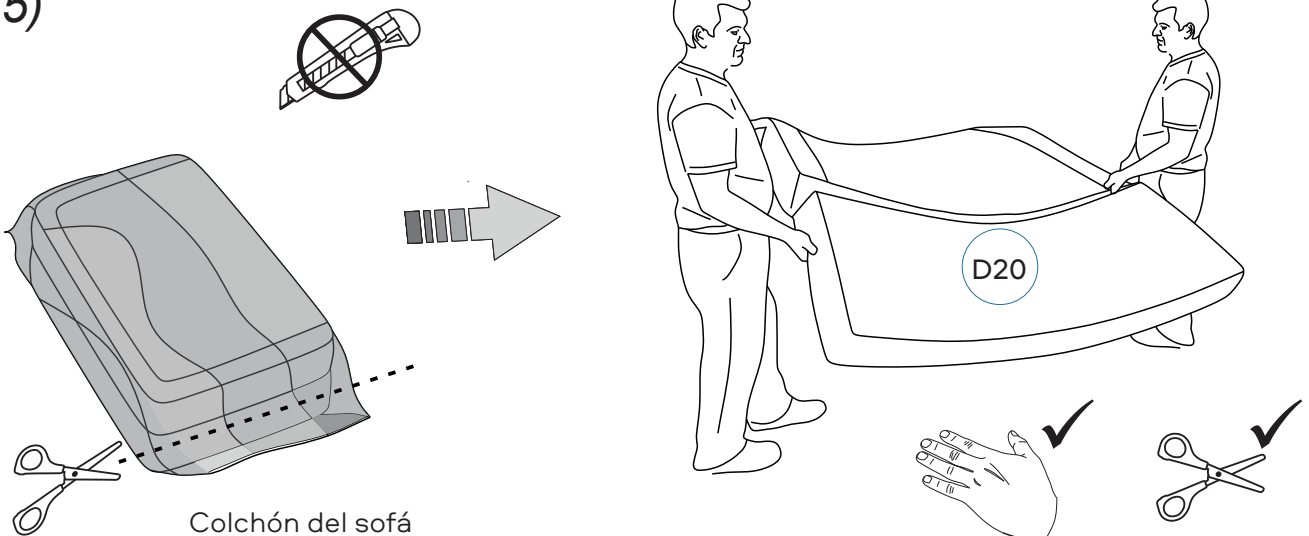

Colchón del sofá

16)

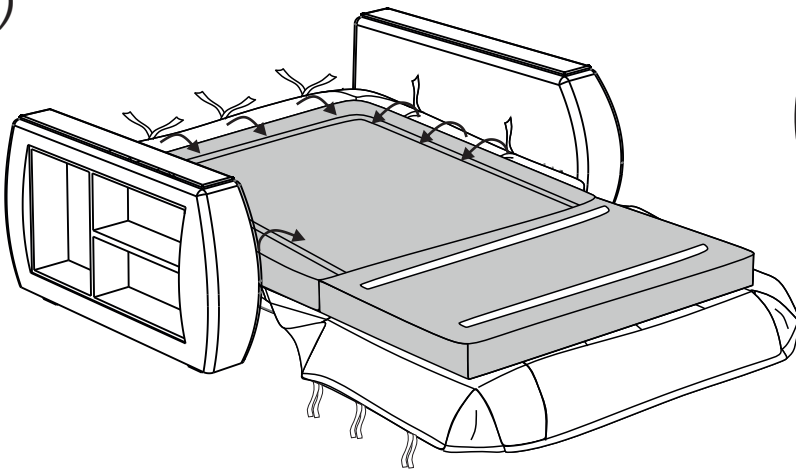

Alinee las costuras y los ángulos del colchón y los de la funda.  
En la cabecera, pase las cintas de contacto en los orificios de la funda.

17)

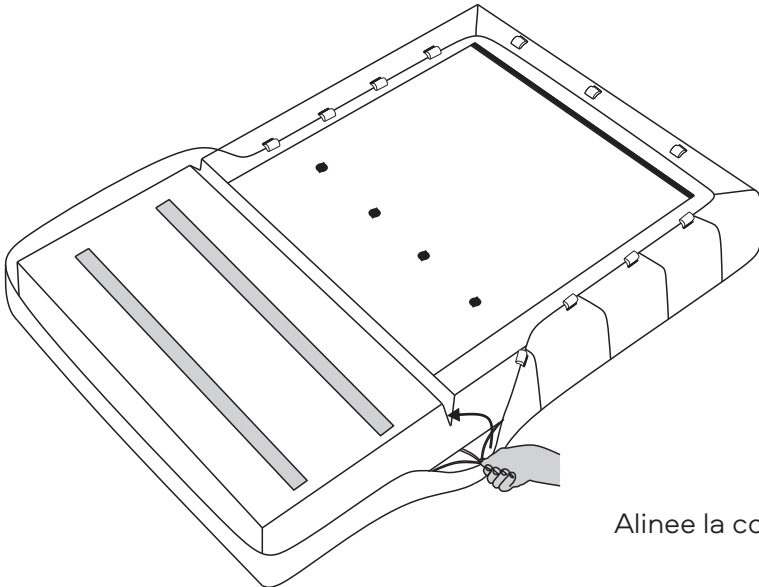

Alinee la costura de la funda con la del colchón.

18)

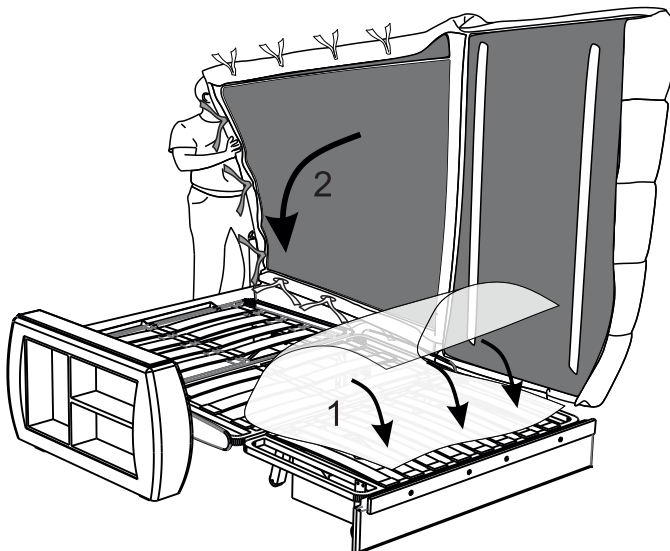



19)

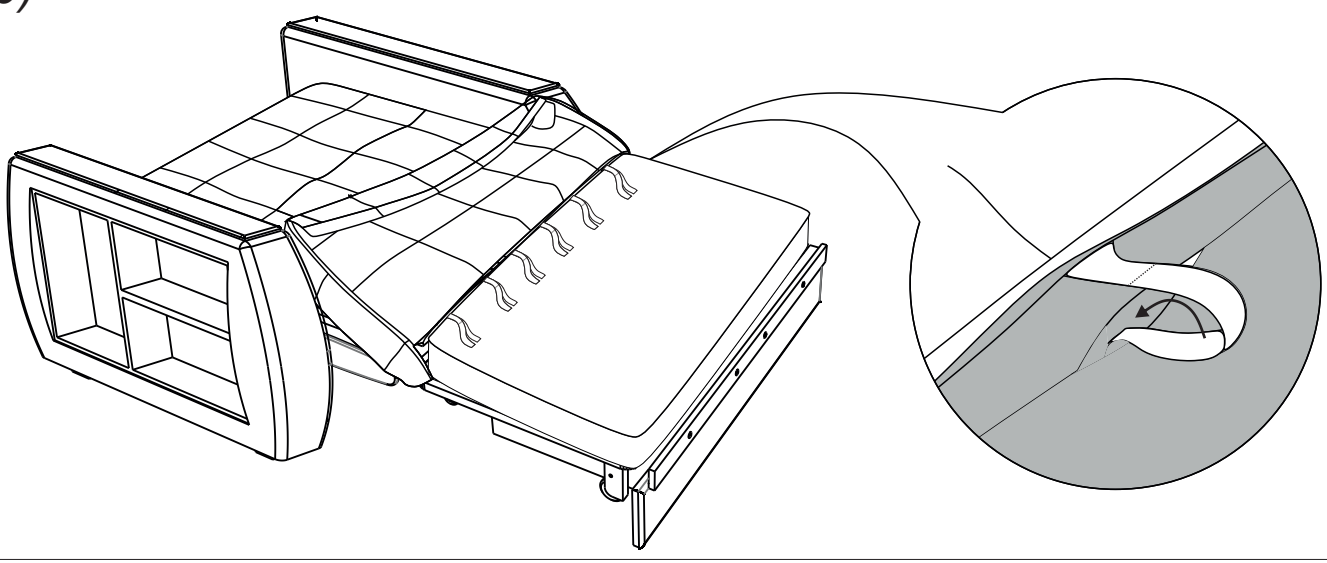

20)

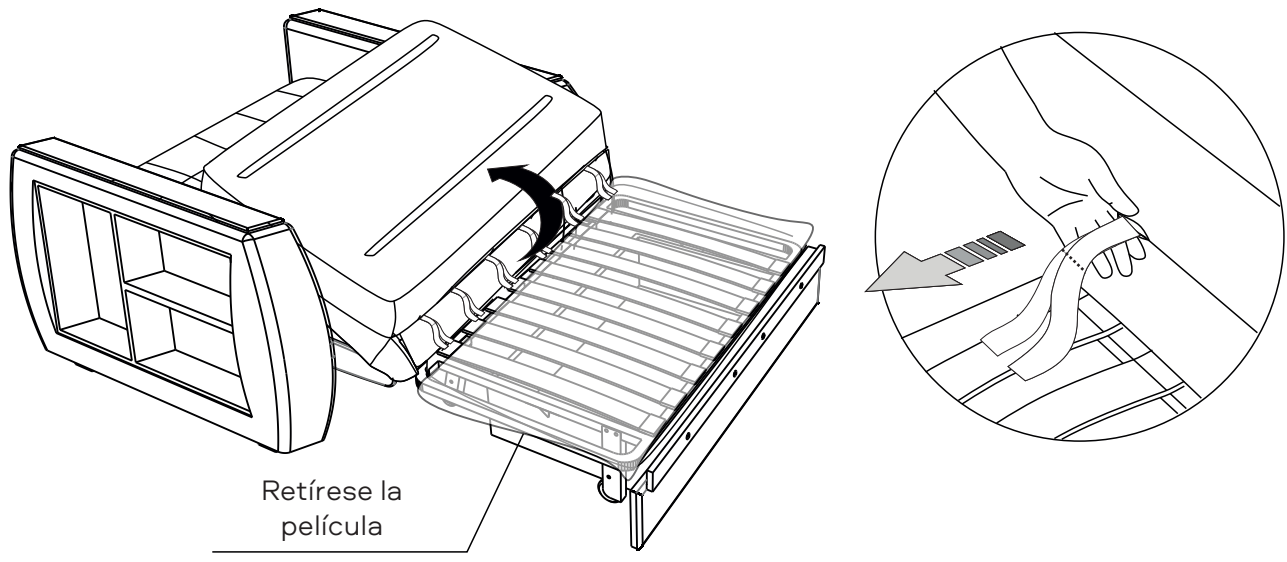

21)

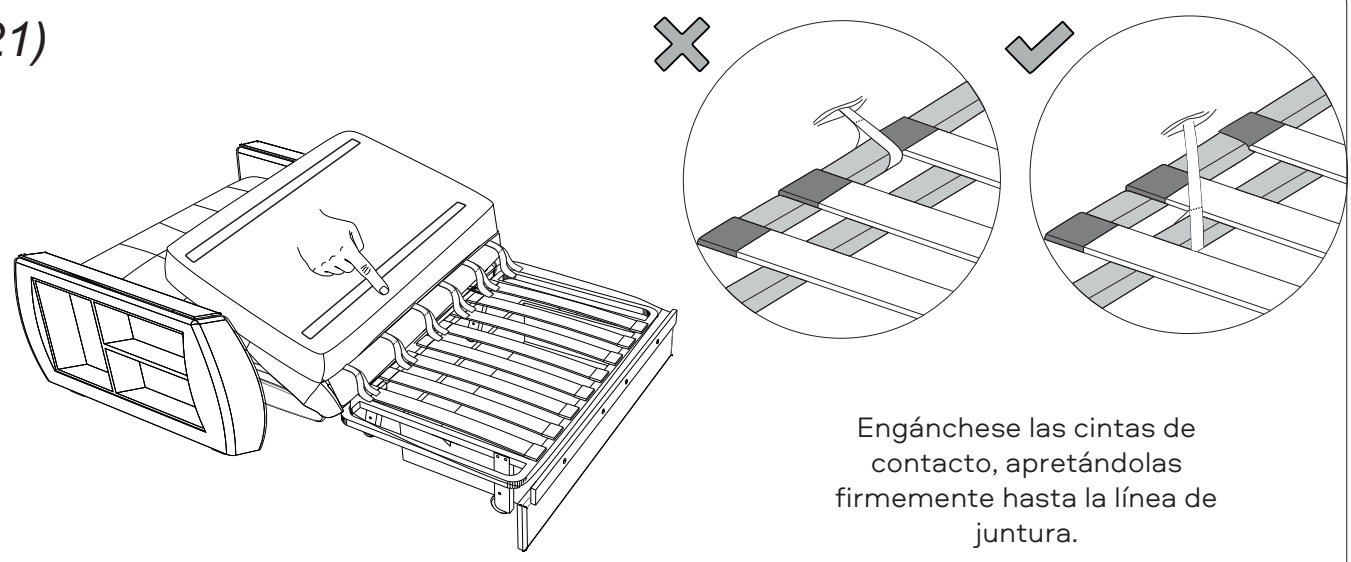

22)

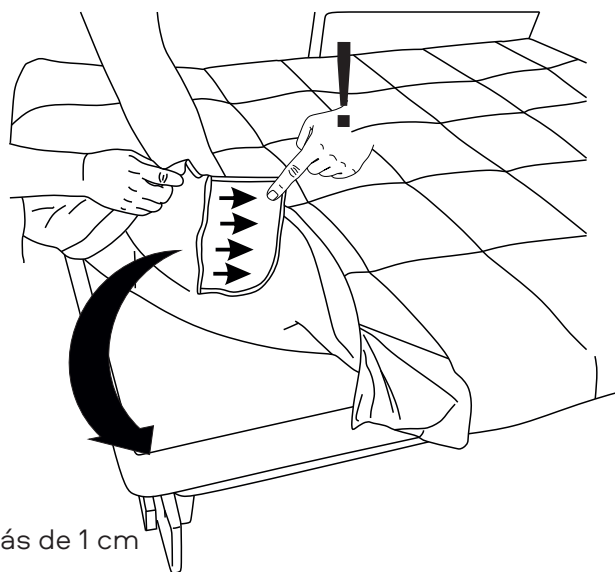
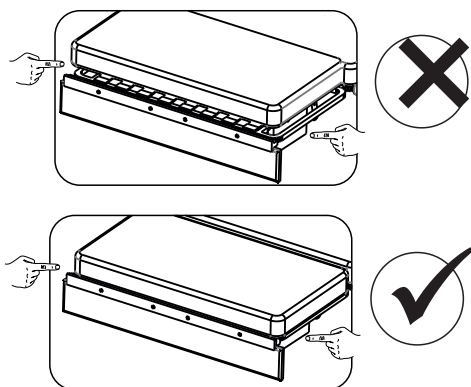

El colchón no debe sobresalir del borde del listón por más de 1 cm

23)

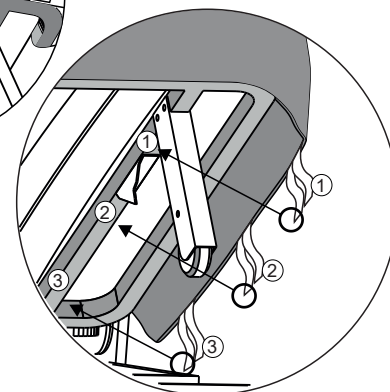
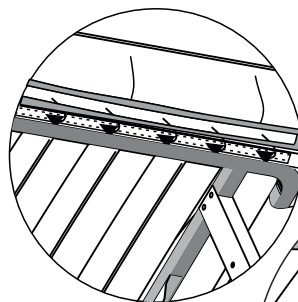
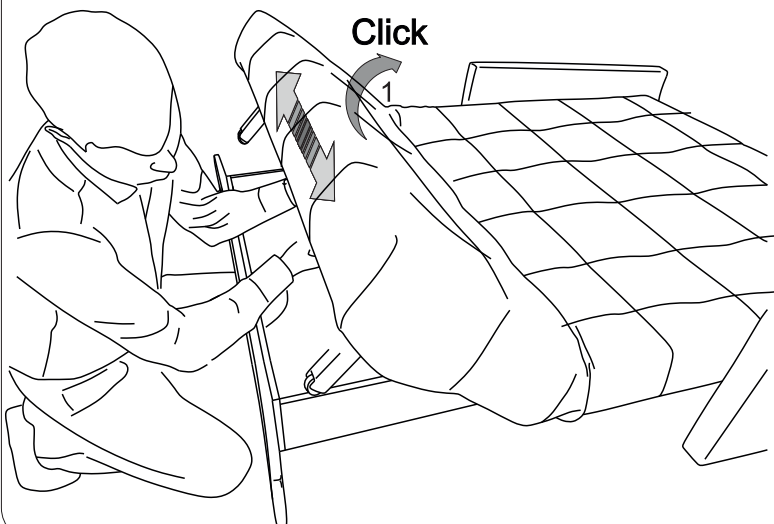

24)

Recójase el exceso de la funda en el lugar del pliegue del colchón para facilitar la transformación

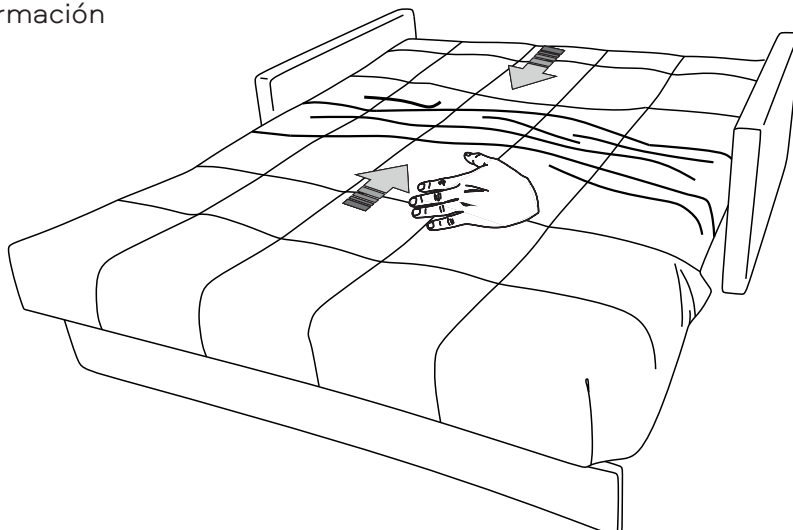

25)

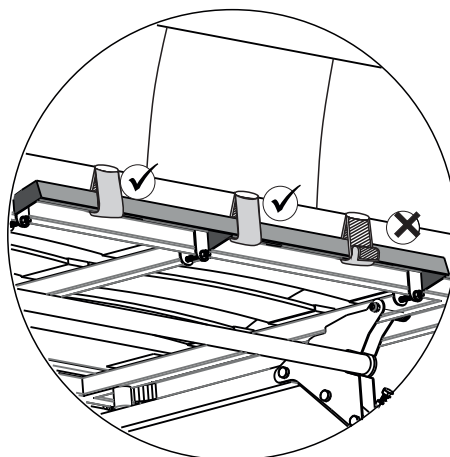
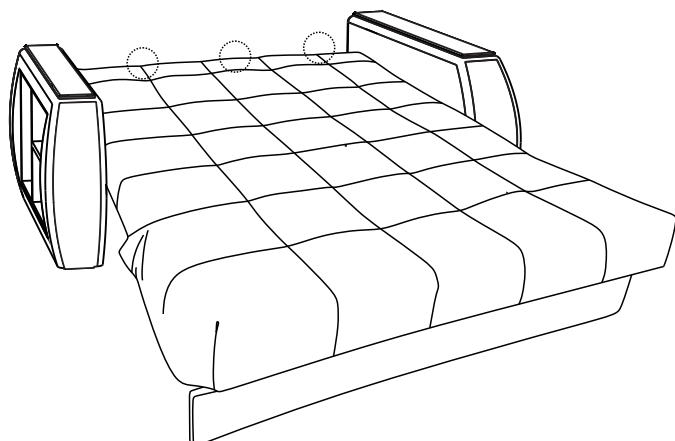

26)

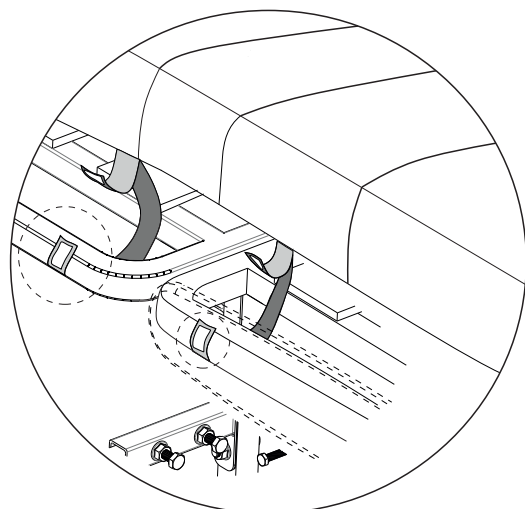
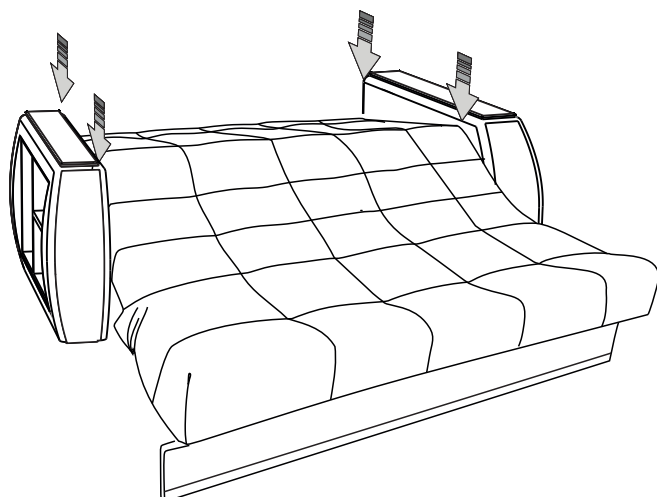

Póngase el sofá a una posición semi-extendida.  
Al fijarlo, las cintas de contacto deben apretarse lo más posible.

27)

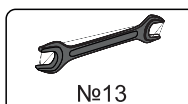
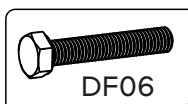
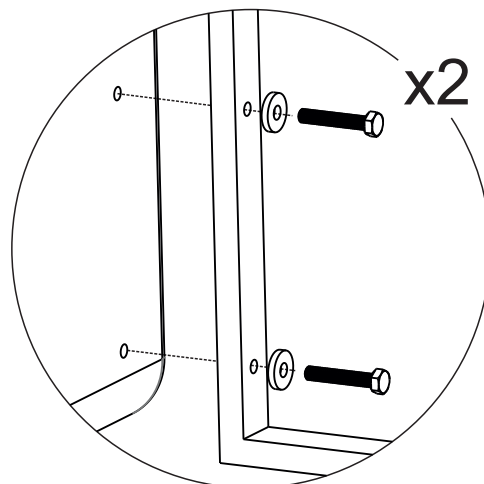
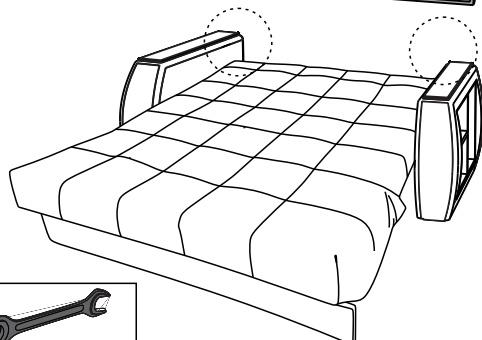
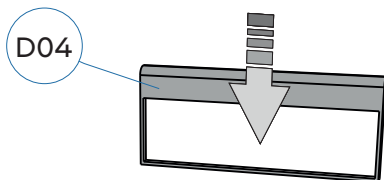

Si se dispone de canapé, proceda a ensamblar el sofá rinconera

28)

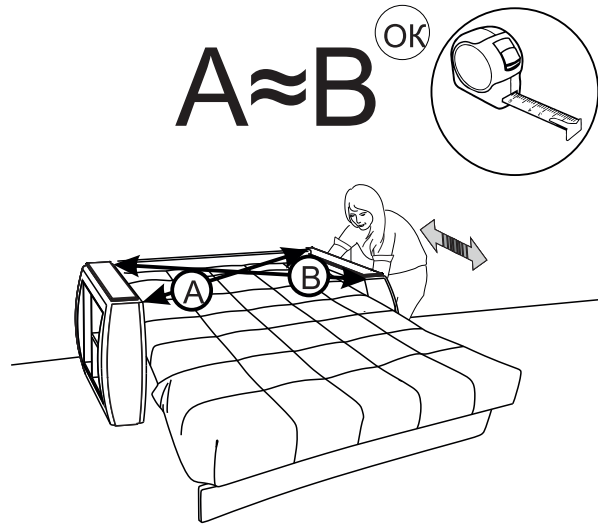
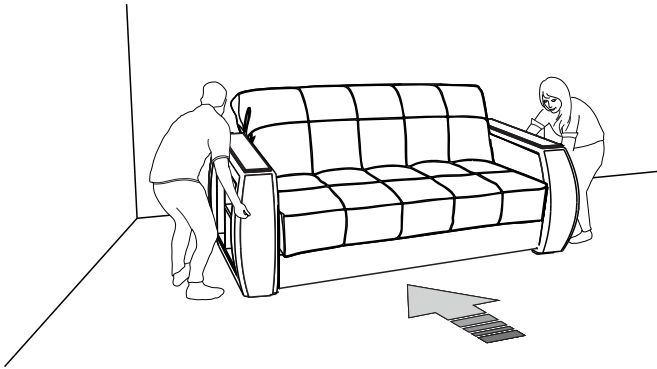

Colóquese el sofá en el lugar de su uso constante

29)

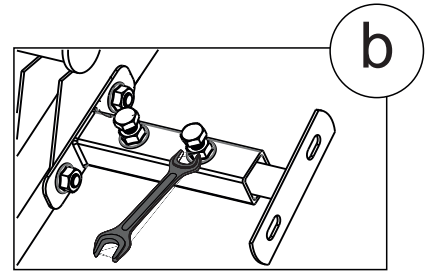
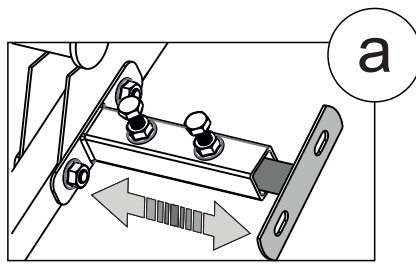
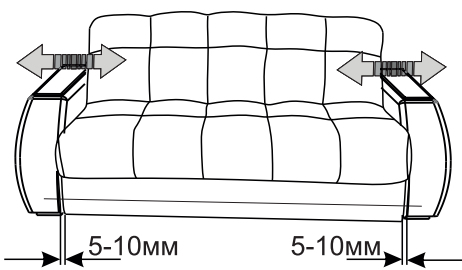

¡Apriételo!

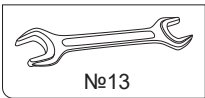

30)

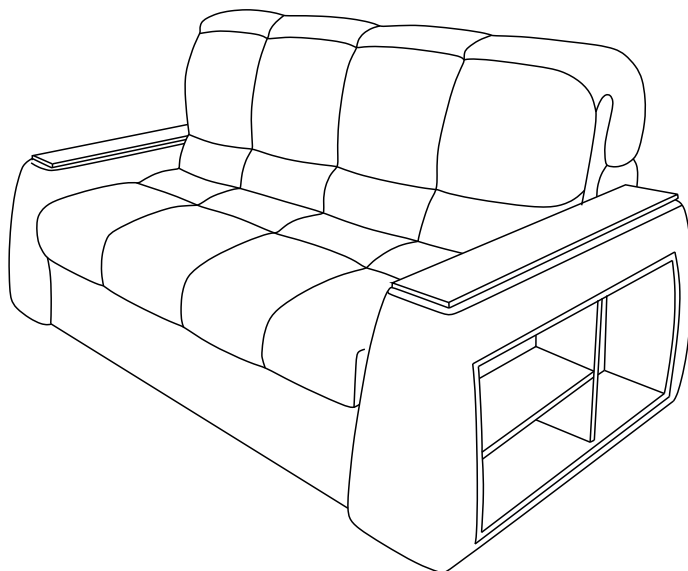

## Ensamblaje del sofá rinconera

31)

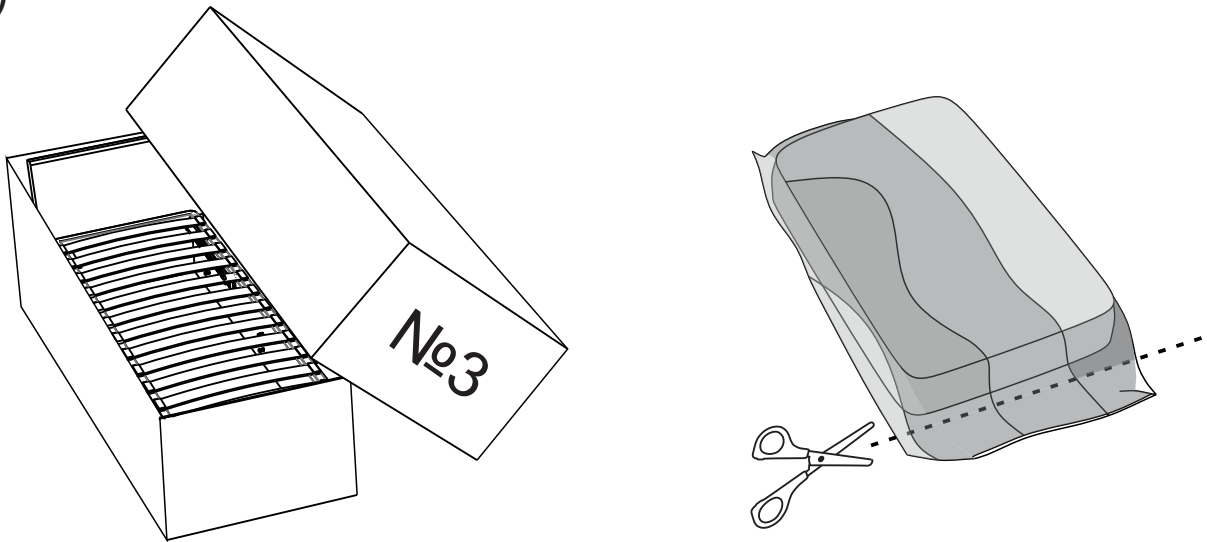

32

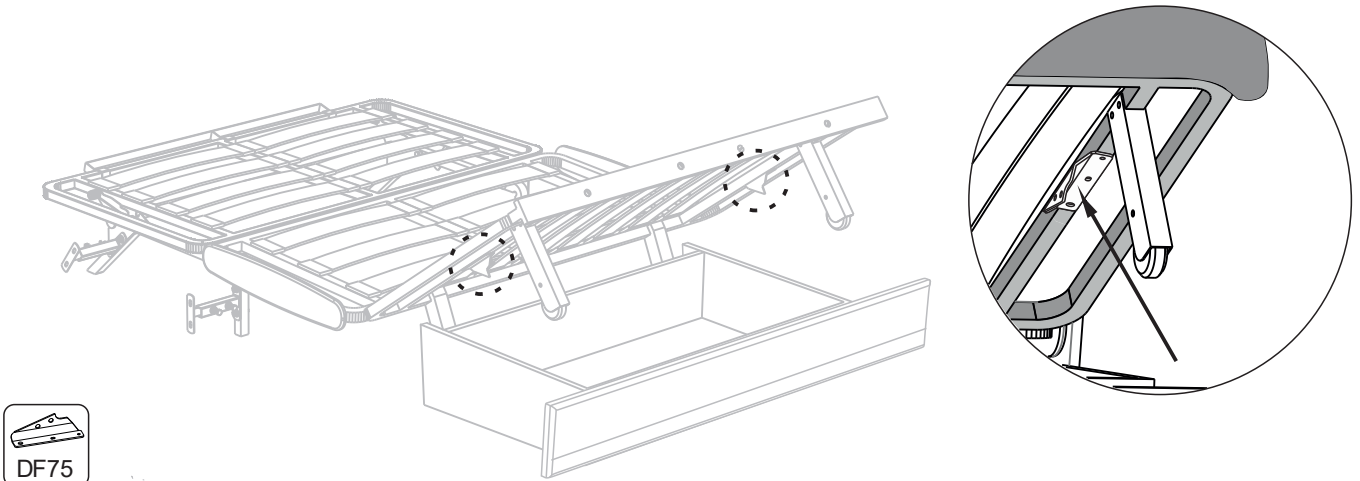

33)

Los resortes se instalan solo en un canapé pequeño

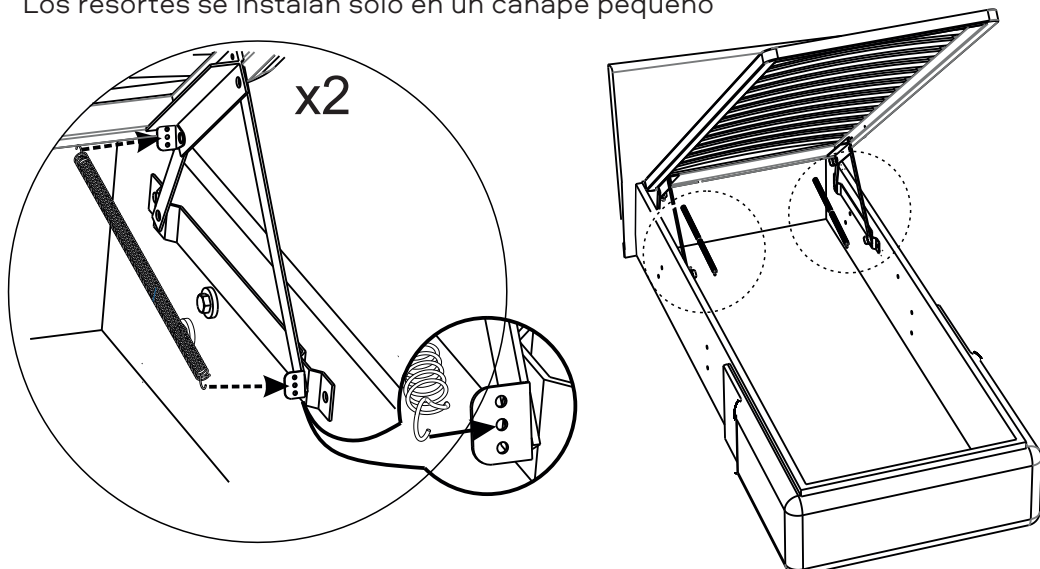

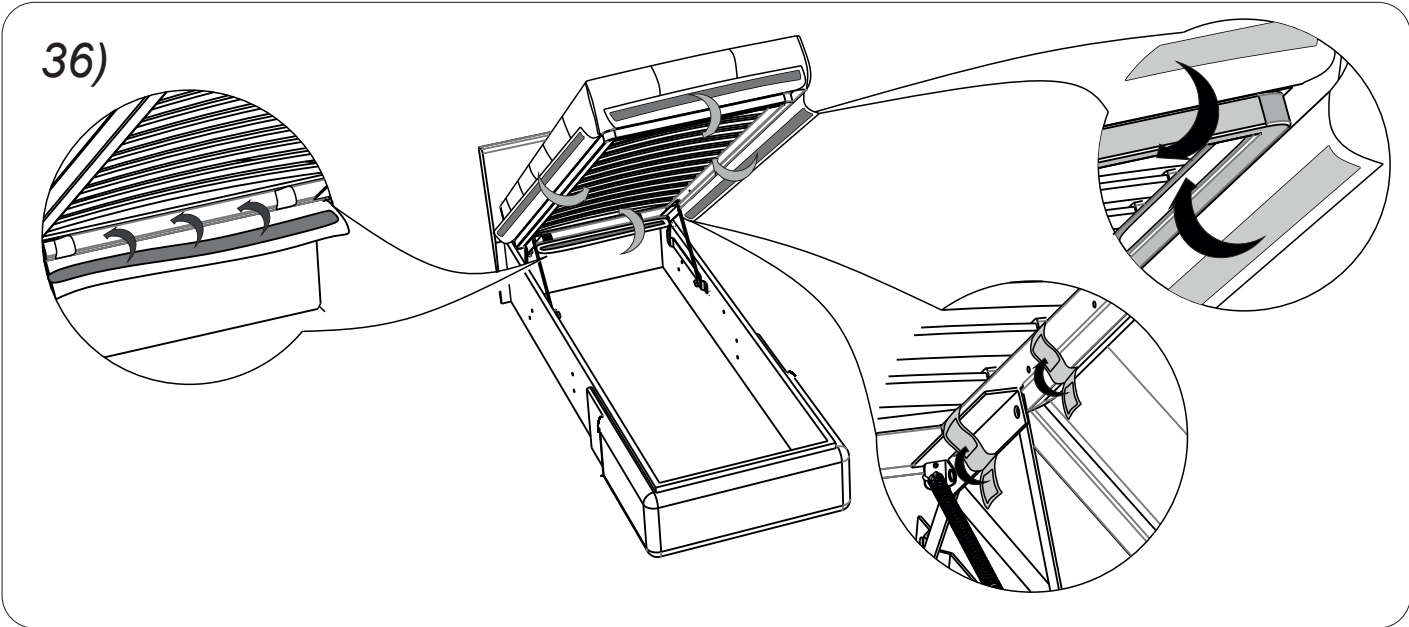
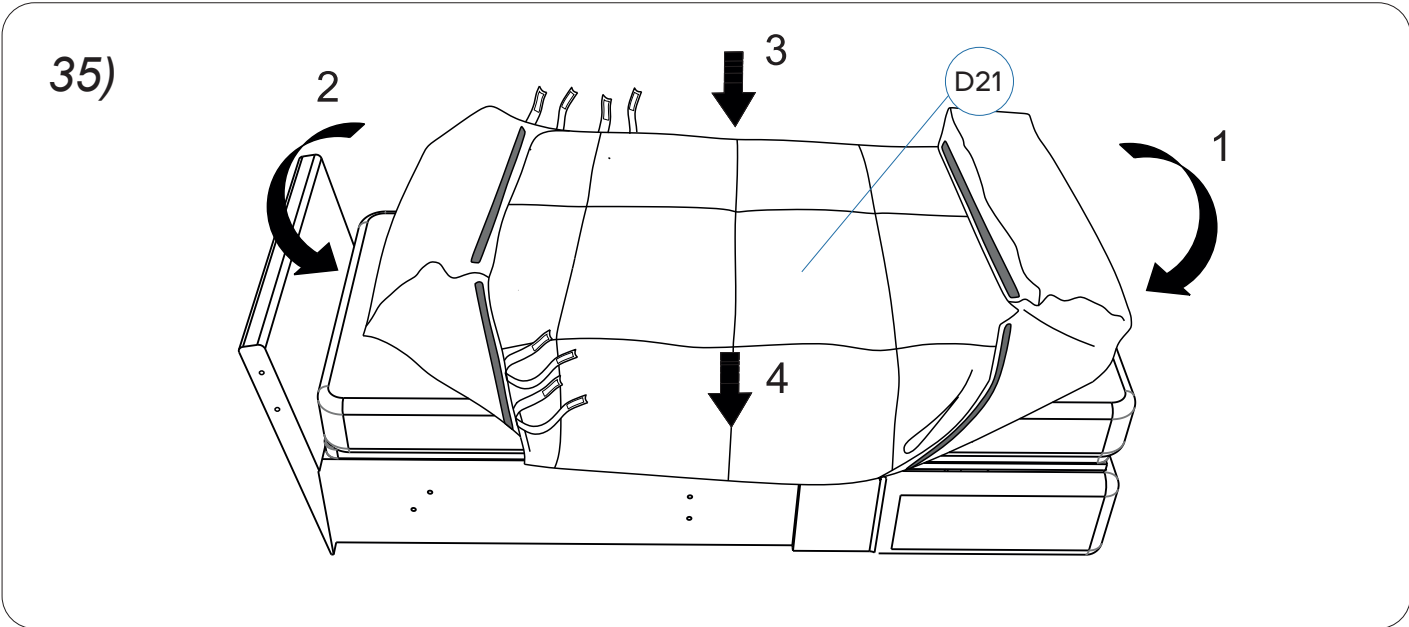
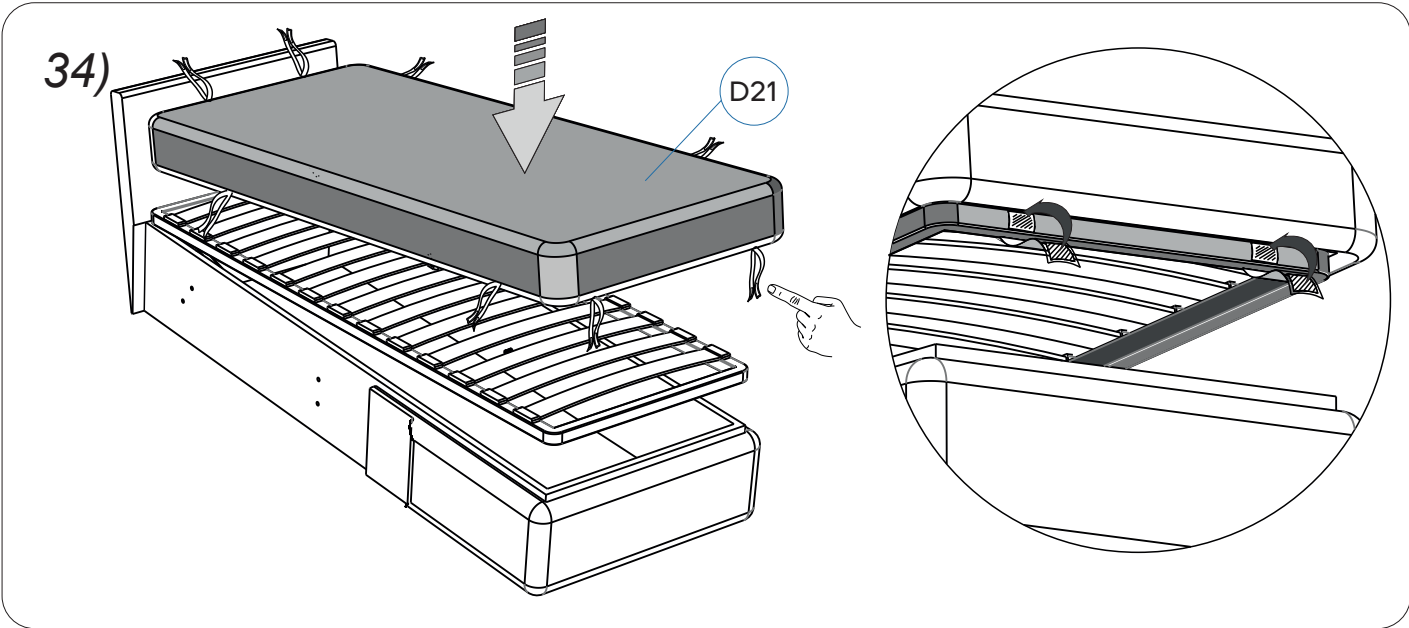



37)

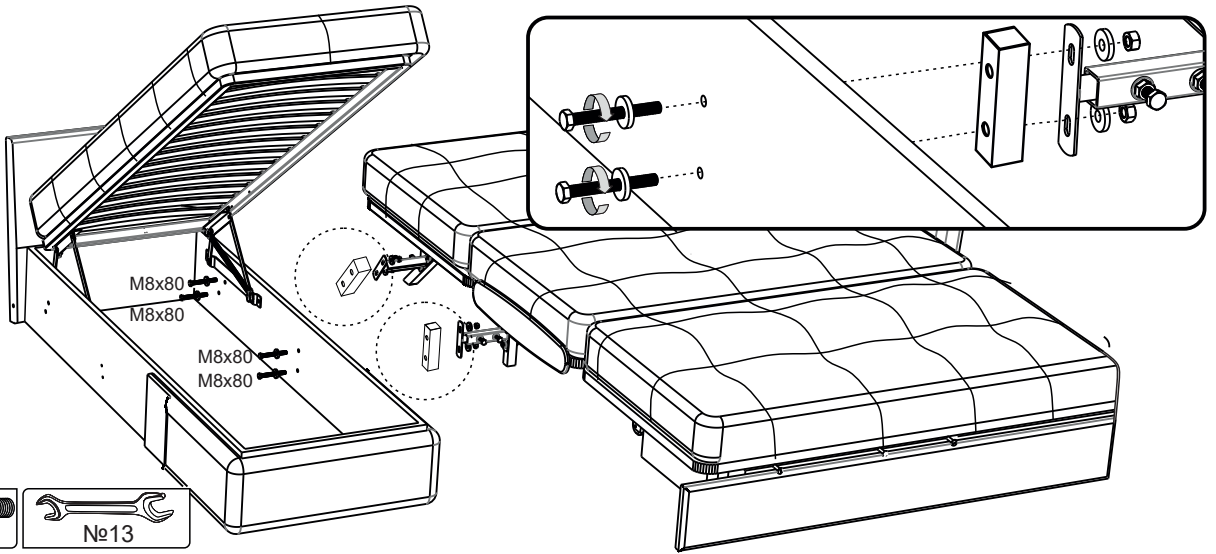

38)

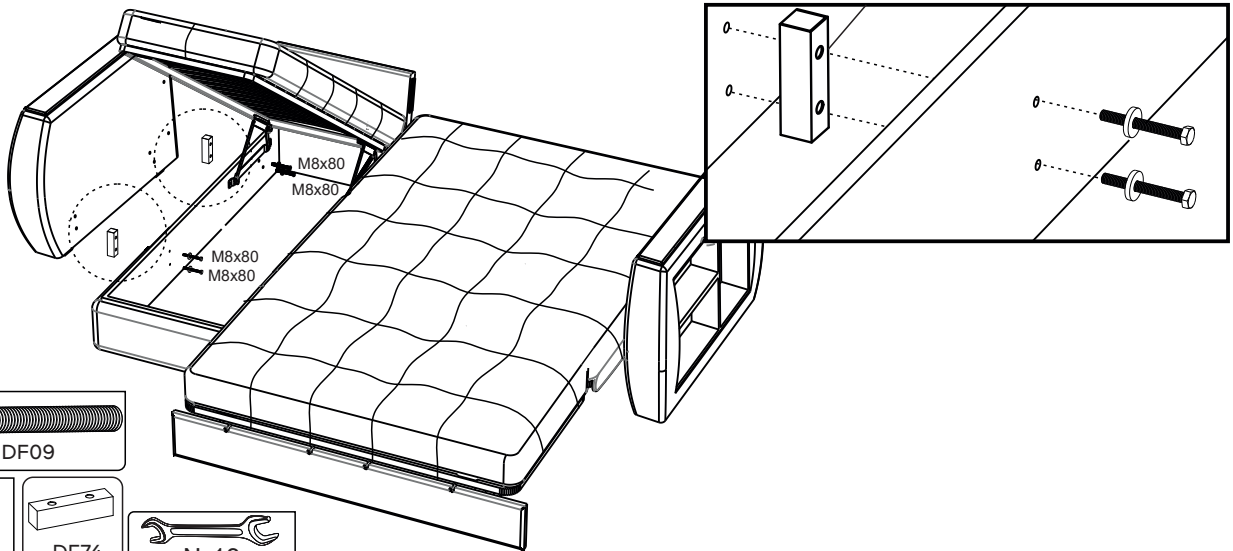

39)

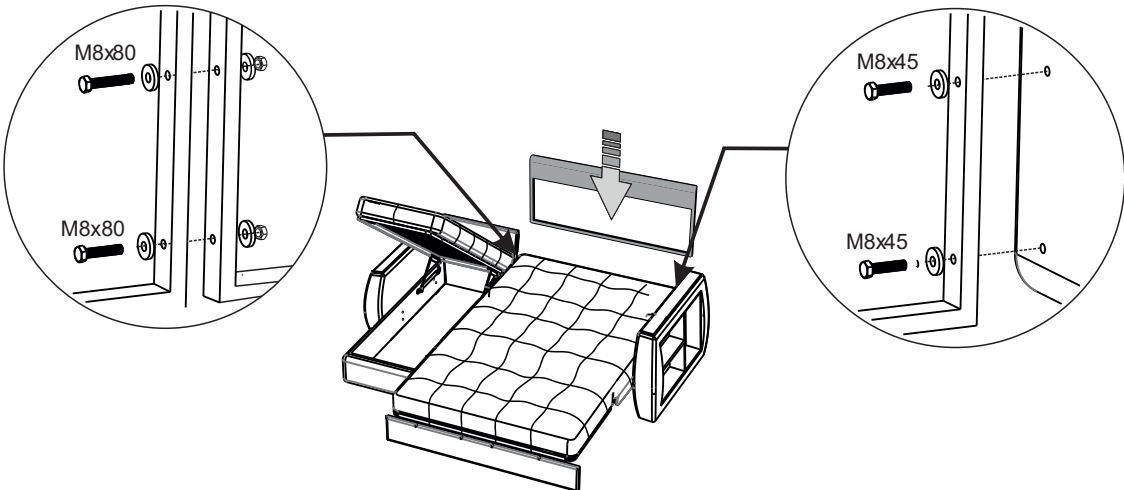



40)

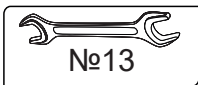
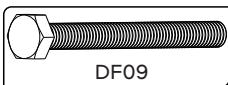
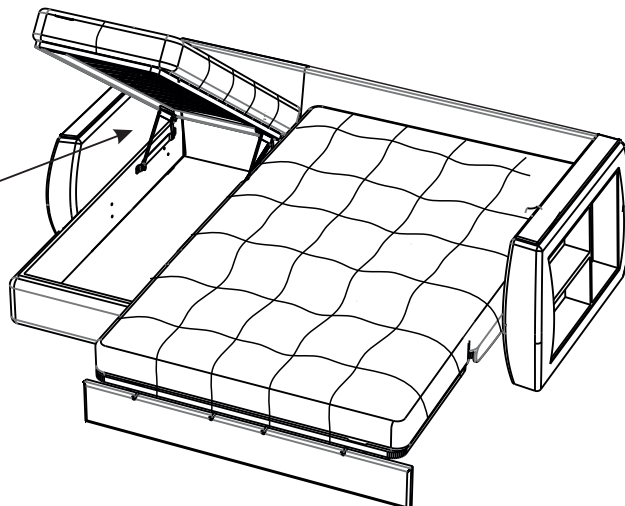
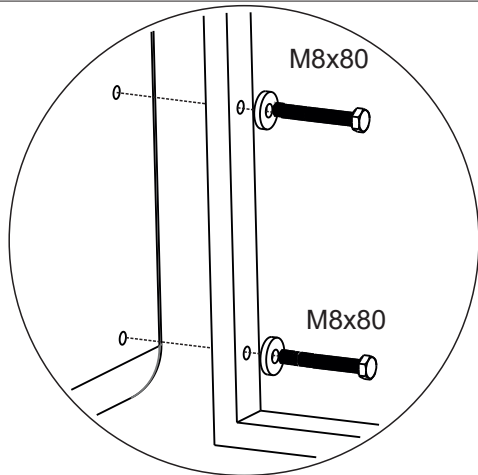

41)

1

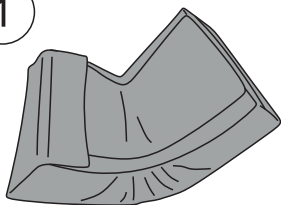

2

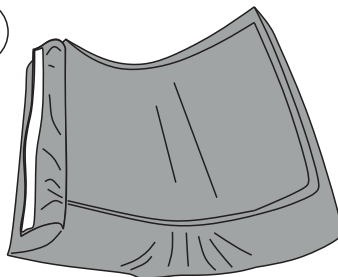

3

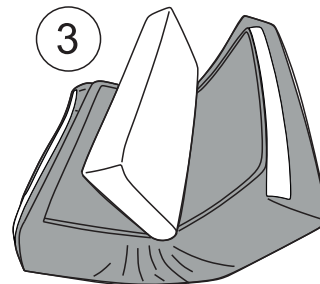

4

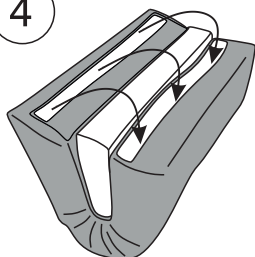

5

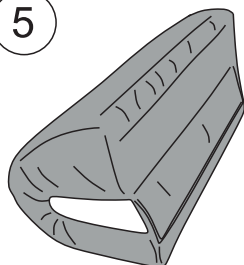

6

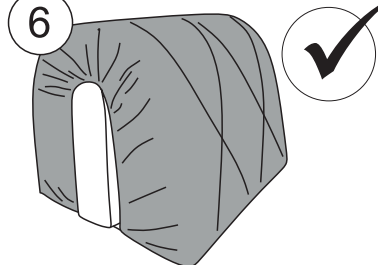

42)

b

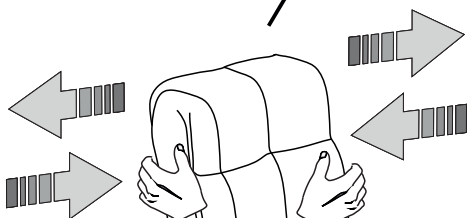

a

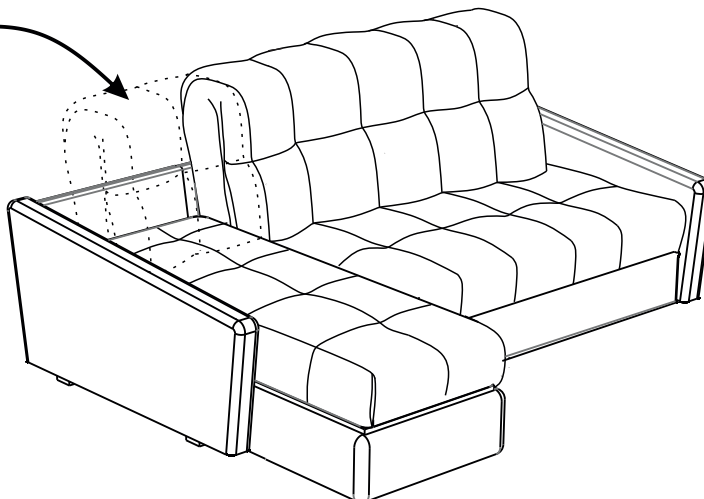

43)

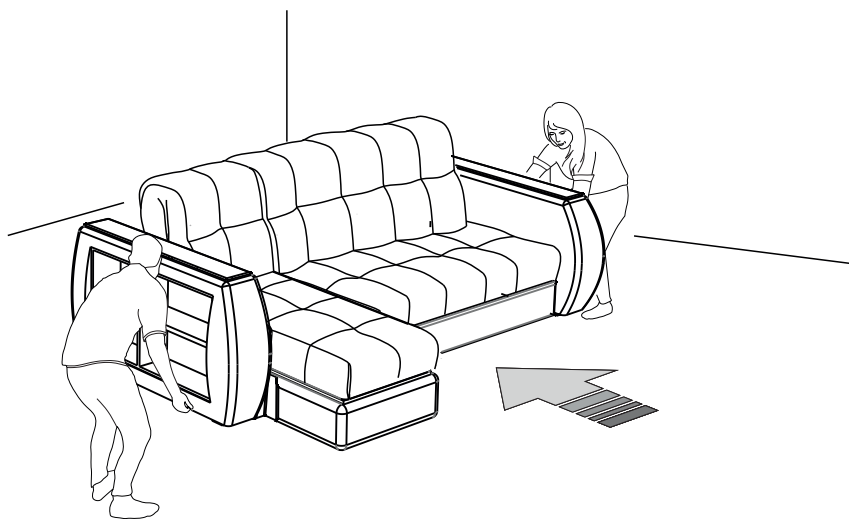

Colóquese el sofá en el lugar de su uso constante

44)

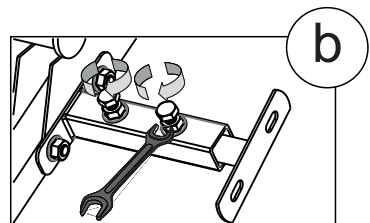
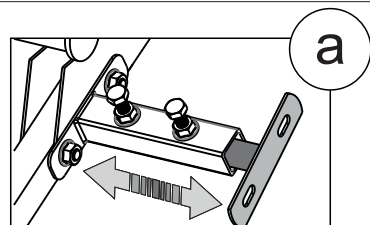
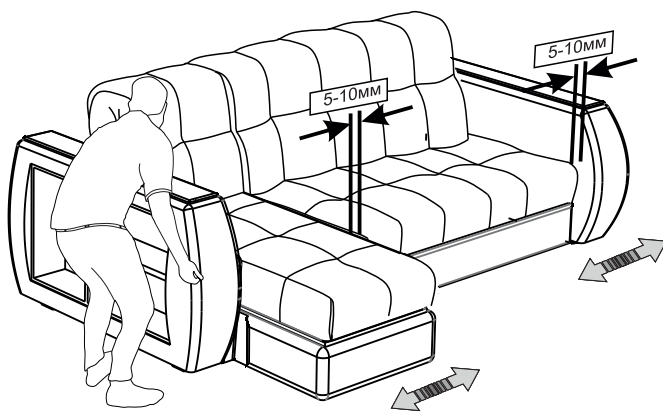

¡Apriételo!



45)

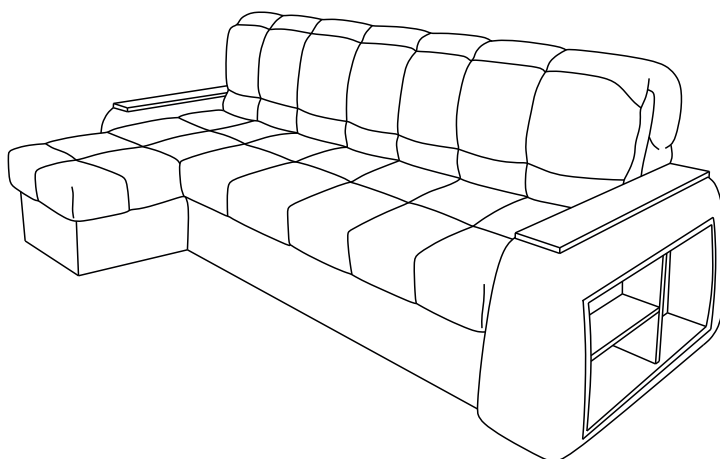

El procedimiento de transformación del sofá

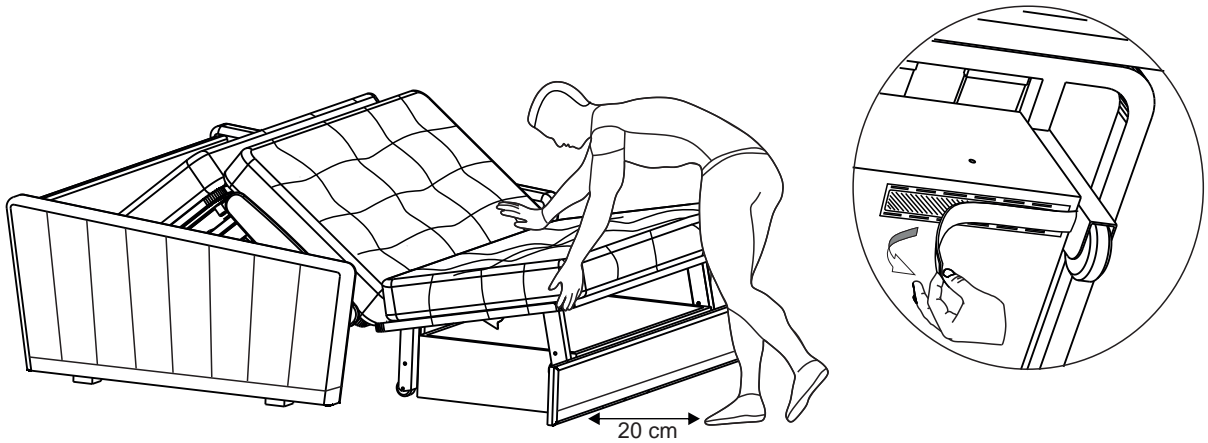
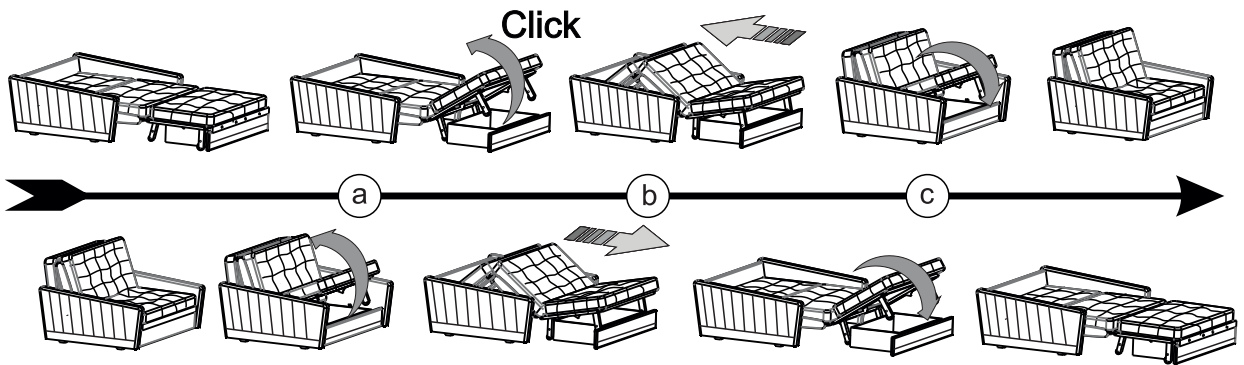

Si el asiento del sofá no se eleva, desabroche el velcro de envío.

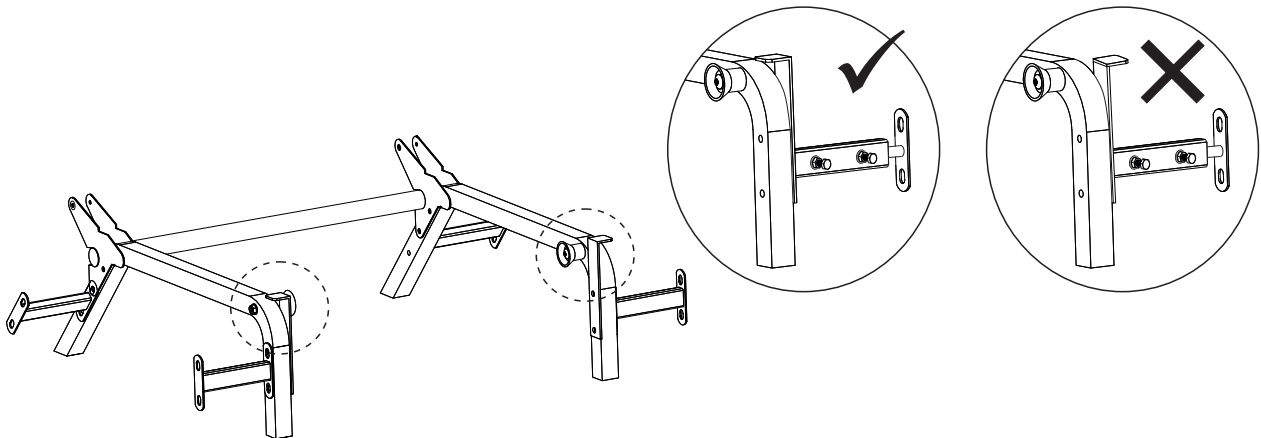

Si el asiento del sofá no se retrae, verifique la posición de los soportes en el mecanismo

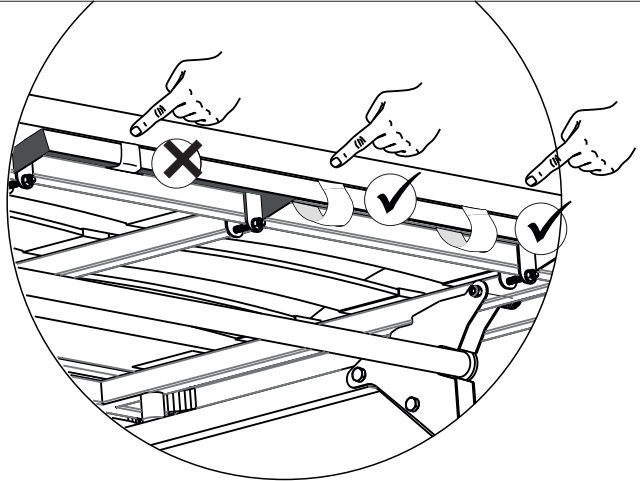
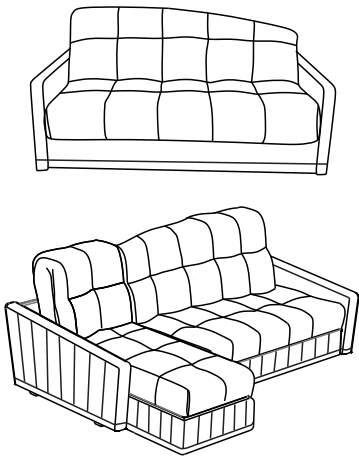

Si el respaldo está inclinado, afloje las cintas de contacto en la cabecera.

Si hay un espacio grande entre el colchón y el reposabrazos, levante el área del asiento y afloje las cintas de contacto.

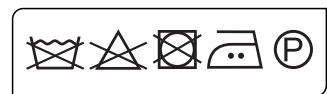
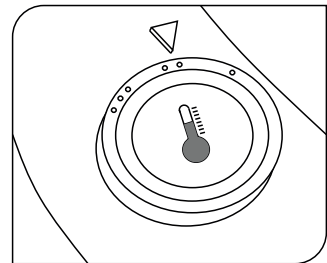
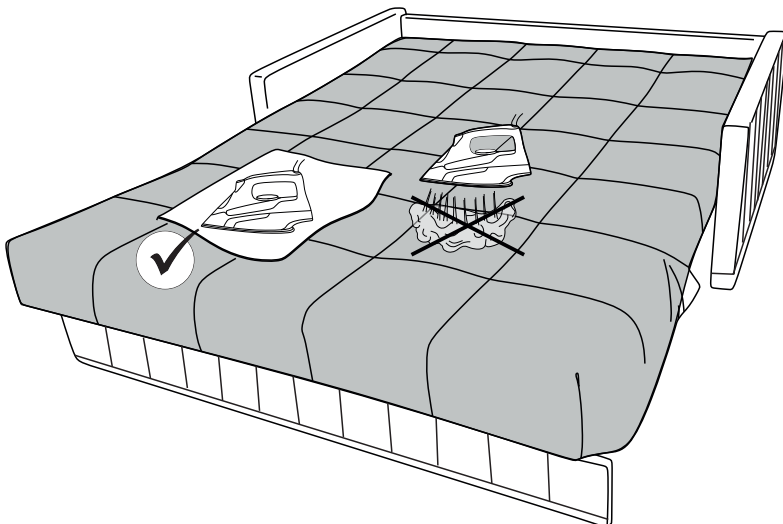
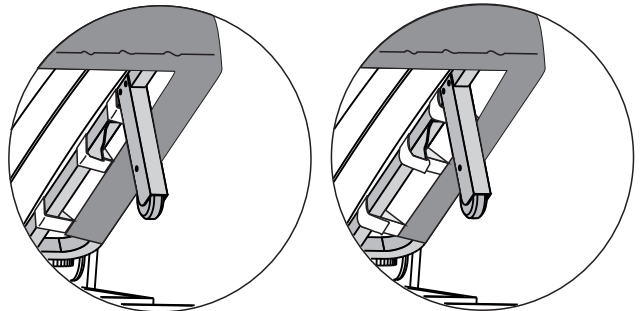
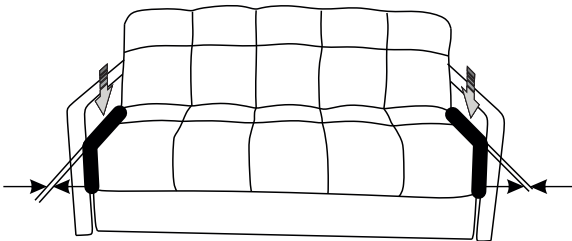
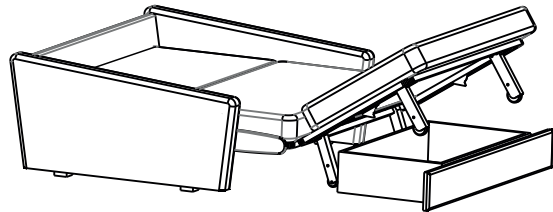

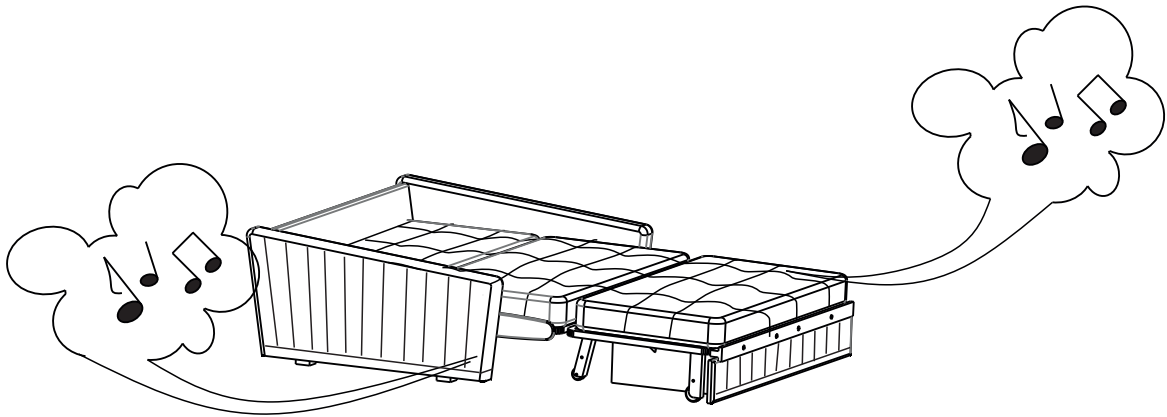

Recuerde: el chirrido característico de las partes metálicas del mecanismo durante la transformación constante es normal. En el corazón del sofá se encuentra una robusta estructura de metal que se puede transformar en una cama todos los días. Durante la transformación y el funcionamiento, la grasa entre las diferentes partes del mecanismo puede secarse y aparece la fricción de los elementos metálicos entre sí. Para evitar la ocurrencia de la fricción y el chirrido del mecanismo durante la transformación o el funcionamiento, es importante seguir las siguientes recomendaciones.  
 Si el mecanismo chirría, los elementos de fricción deben lubricarse. Tira las conexiones.  
 Lubricar al menos una vez cada 6 meses.

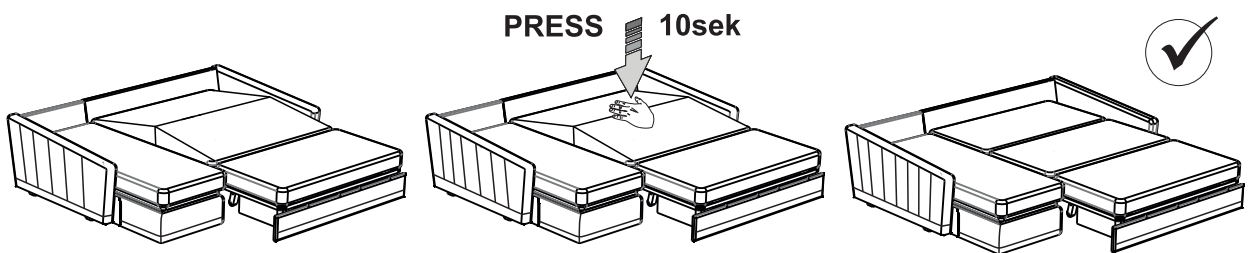
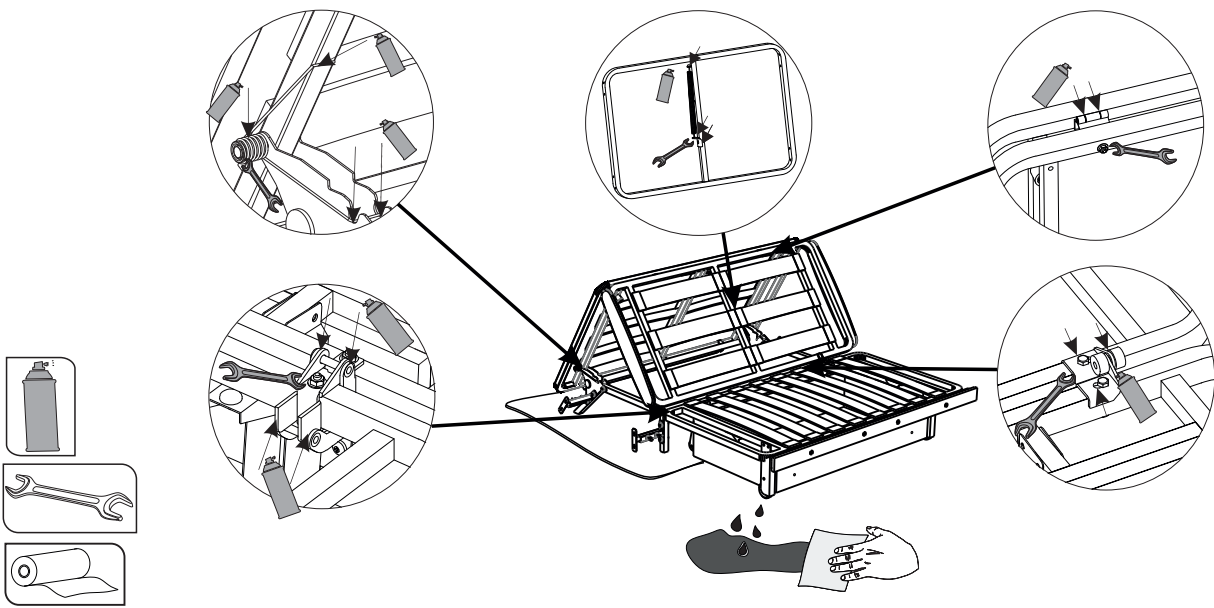

Mantener presionado durante 10 segundos

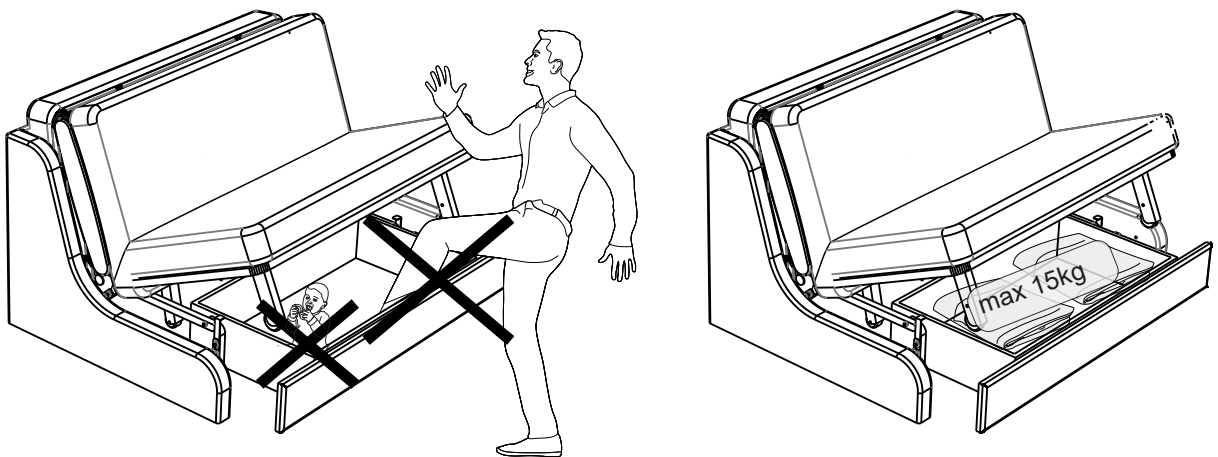
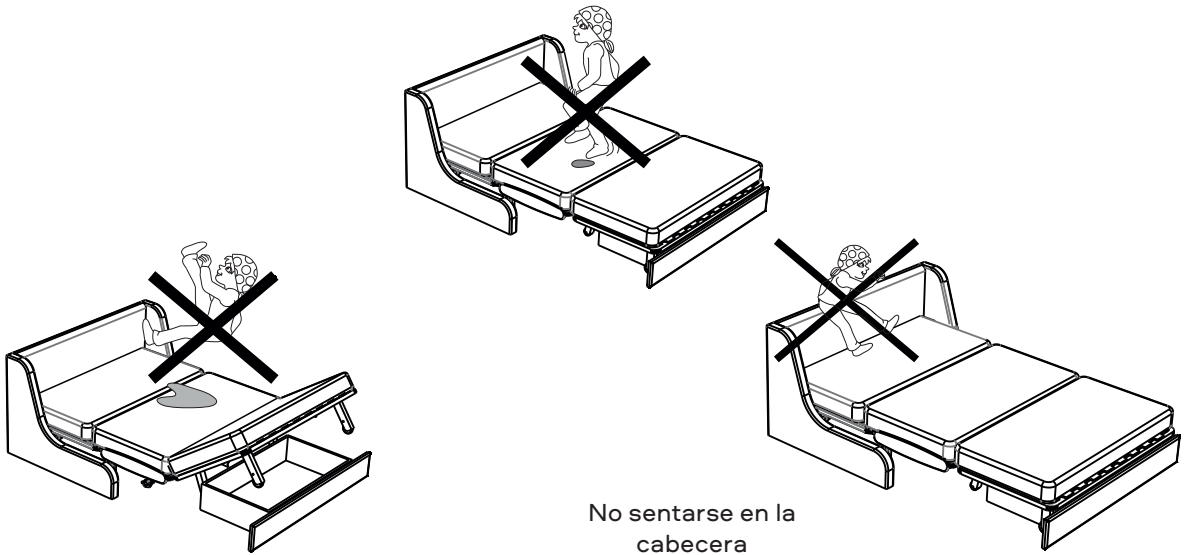
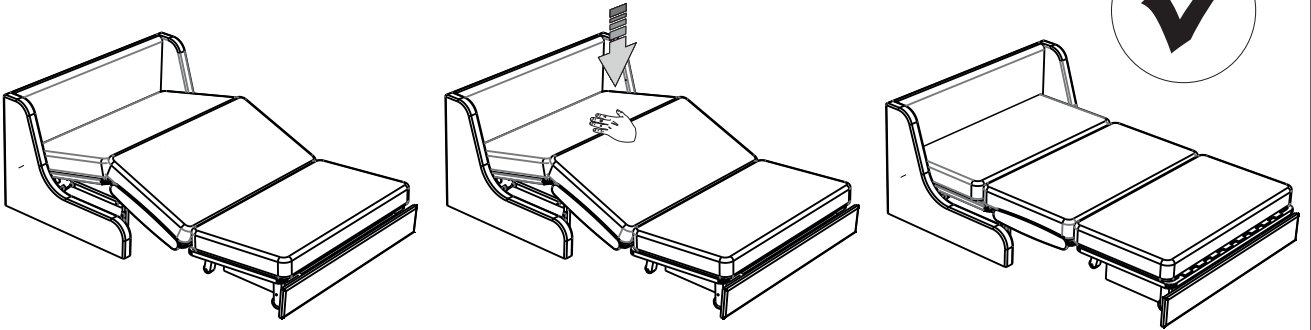

# SUNSET NOVA



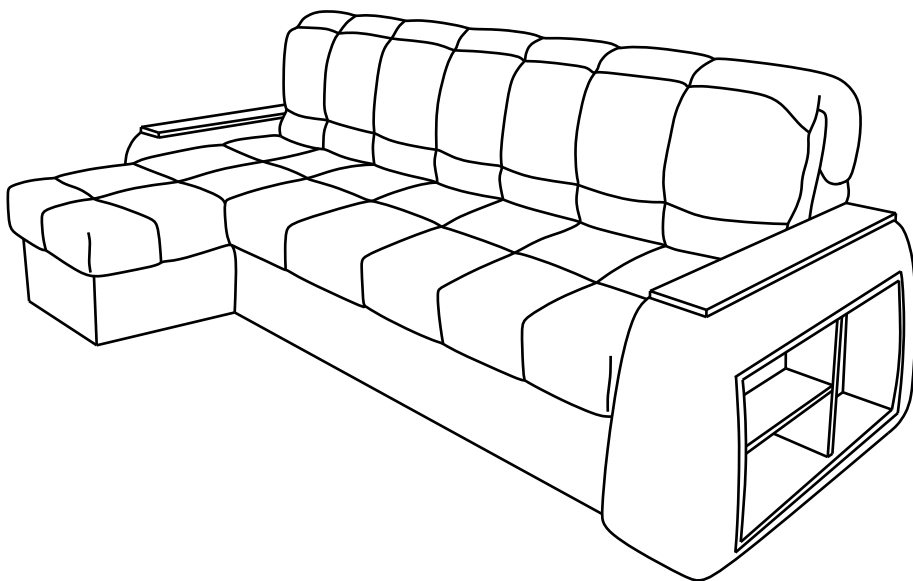
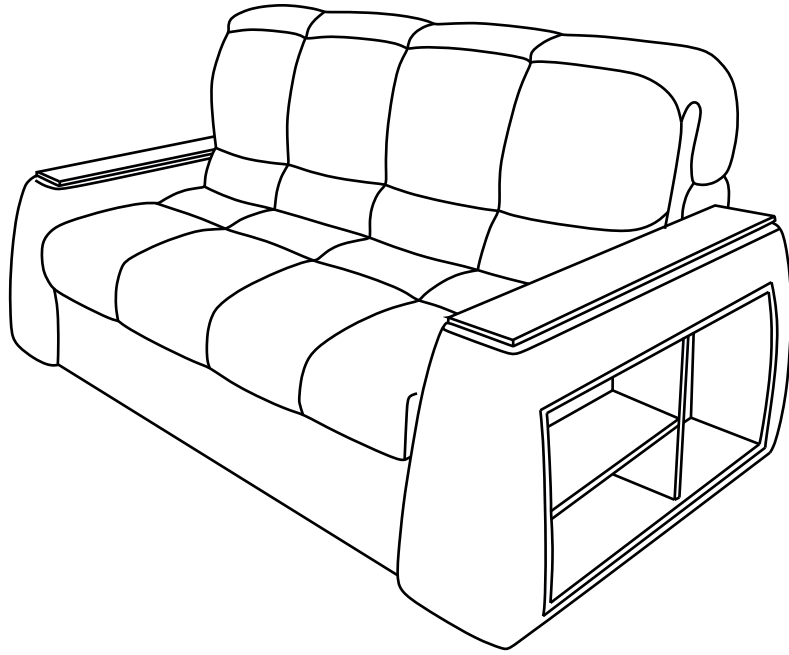





PT





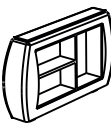
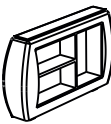
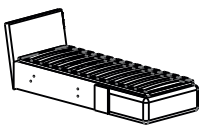

Sleep.8

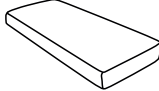



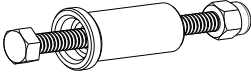
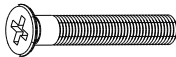

## Lista de peças do sofá

Embalagem	Peça	Código de referência	Nome	Quantidade
Nº 1		D01	Mecanismo de transformação	1
		D26	Suporte do mecanismo de transformação	1
		D04	Encosto	1
		D05	Barra	1
		D07	Capa acolchoada	1
			Pacote com as ferragens	1
			Instruções de montagem, amostra de tecido	1
Nº 2		D06	Braço	1
Nº 3		D06	Braço	1
Nº 4 opção adicional ao encomendar o sofá com o canapé		D14	Canapé	1
		D11	Almofada para canapé	1
		D08	Capa do canapé, amostra do tecido do canapé	1
			Pacote com as ferragens para o canapé	1
			Instruções de montagem, amostra de tecido	1
Fornecido separadamente		D20	Colchão	1
		D21	Colchão do canapé	1

### Lista de ferragens do sofá

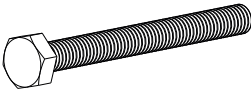
Embalagem	Peça	Código de referência	Nome	Quantidade
Pacote com as ferragens		DF02 DF15 DF16	Parafuso M6x65 Bucha de plástico Porca M6 (autotravante)	2
		DF11	Parafuso de cabeça escareada M6x30	3
		DF31	Mola com agarras	2
		DF06	Parafuso M8x45	4
		DF56	Parafuso M8x30	8
		DF42	Arruela M8	4



### Lista de ferragens do canapé

Embalagem	Peça	Código de referência	Nome	Quantidade
Pacote com as ferragens		DF30	Mola de canapé (apenas para o canapé pequeno)	2
		DF09	Parafuso M8x80	10
		DF19	Porca M8	6
		DF42	Arruela M8	14
		DF74	Barra de ajuste para canapé	4
		DF75	Parada do mecanismo	2

**Antes da montagem:**

- 1) Verifique o tipo e a integridade das peças na embalagem!** Queixas sobre danos só serão aceitas para produtos SEM marcas de uso.
- 2) Guarde a embalagem e as instruções até o término da montagem!** Caso identifique-se peças faltantes ou defeitos durante o processo de montagem do produto, é necessário guardar a embalagem até à visita de um representante comercial da empresa.
- 3) Verifique a quantidade de peças e ferragens seguindo a lista.** O fabricante possui o direito de implementar mudanças estruturais no produto, substituir ferragens e peças metálicas por semelhantes, que não afetam a aparência externa e não alteram as propriedades funcionais do produto. Em caso de peças faltantes ou defeito, destaque o número da peça faltante e comunique à loja para que seja feita a substituição.
- 4) Atenção à ordem de montagem apresentada nestas instruções!** Não seguir as instruções e a operação apresentadas pelo fabricante cancela a garantia do produto.
- 5) Escolha uma superfície plana para a montagem do sofá-cama!** Caso o piso tenha desníveis ou tapetes grossos, é possível que o mecanismo de conversão do sofá-cama não funcione corretamente e pode ocorrer deformações no produto.
- 6) A montagem do sofá-cama deve ser feita por duas pessoas.** Mova todas as peças com cuidado, sem sacudi-las, coloque-as com firmeza, evite quedas e impactos!
- 7) Para movimentar o móvel e suas peças, apenas levante-o um pouco.** Isto evita deformações e quebras.
- 8) É obrigatório lubrificar o mecanismo de elevação durante a montagem seguindo as instruções!** Isto evita rangidos prematuros. Lubrifique e aperte parafusos e porcas soltos pelo menos uma vez a cada seis meses.

**É necessário para a montagem:**

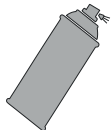
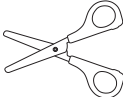
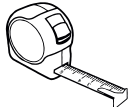
	Chave de fenda
	Chave de boca Nº13 x 1 Chave de boca Nº10 x 2
	Papel toalha
	Lubrificante à base de silicone
	Tesouras
	Fita métrica

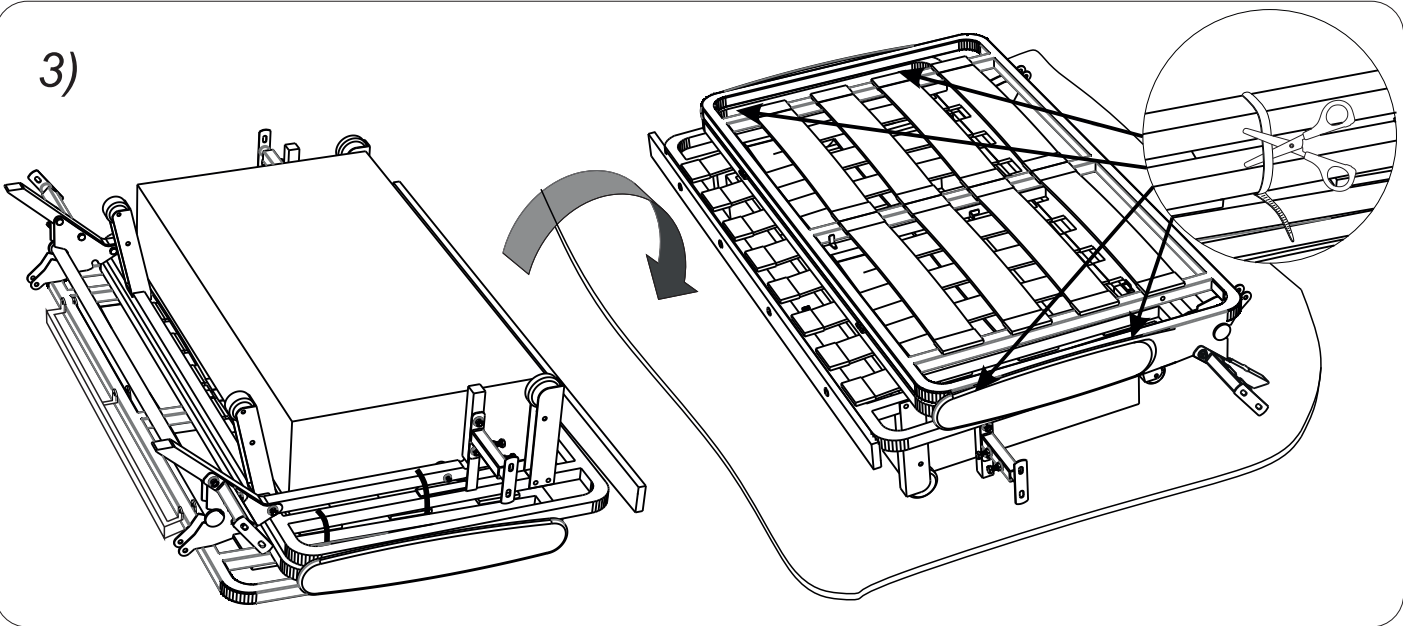
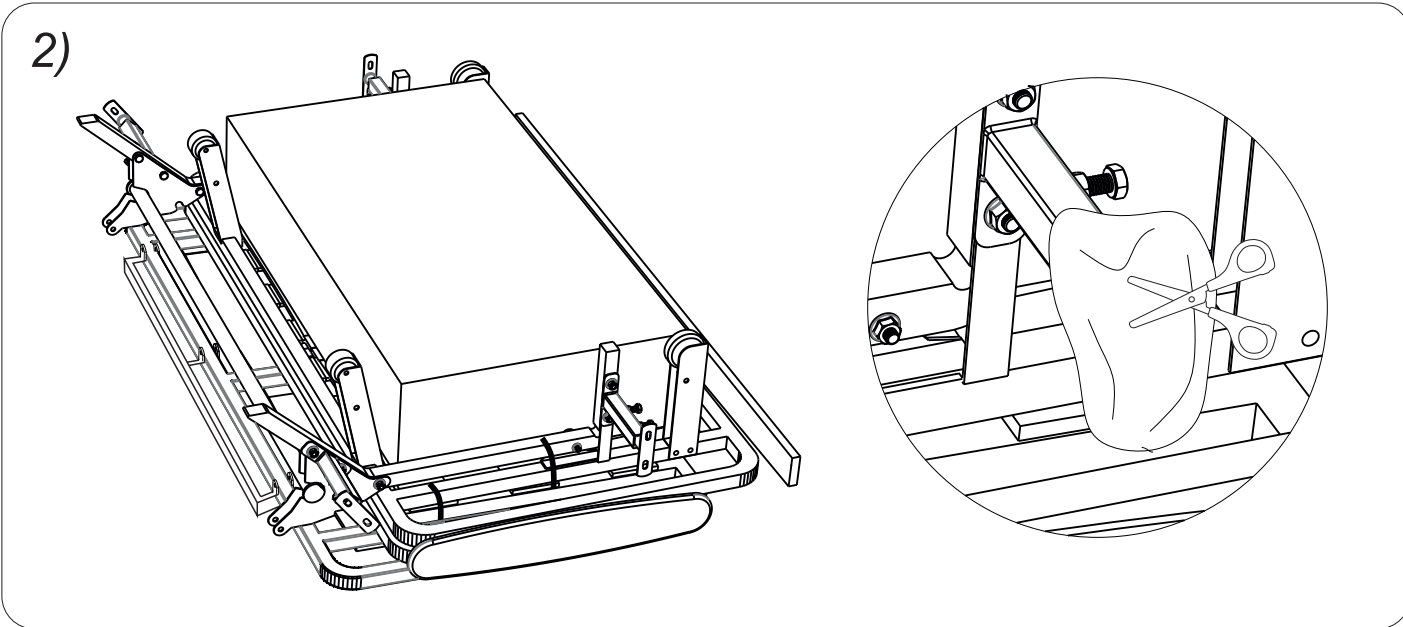
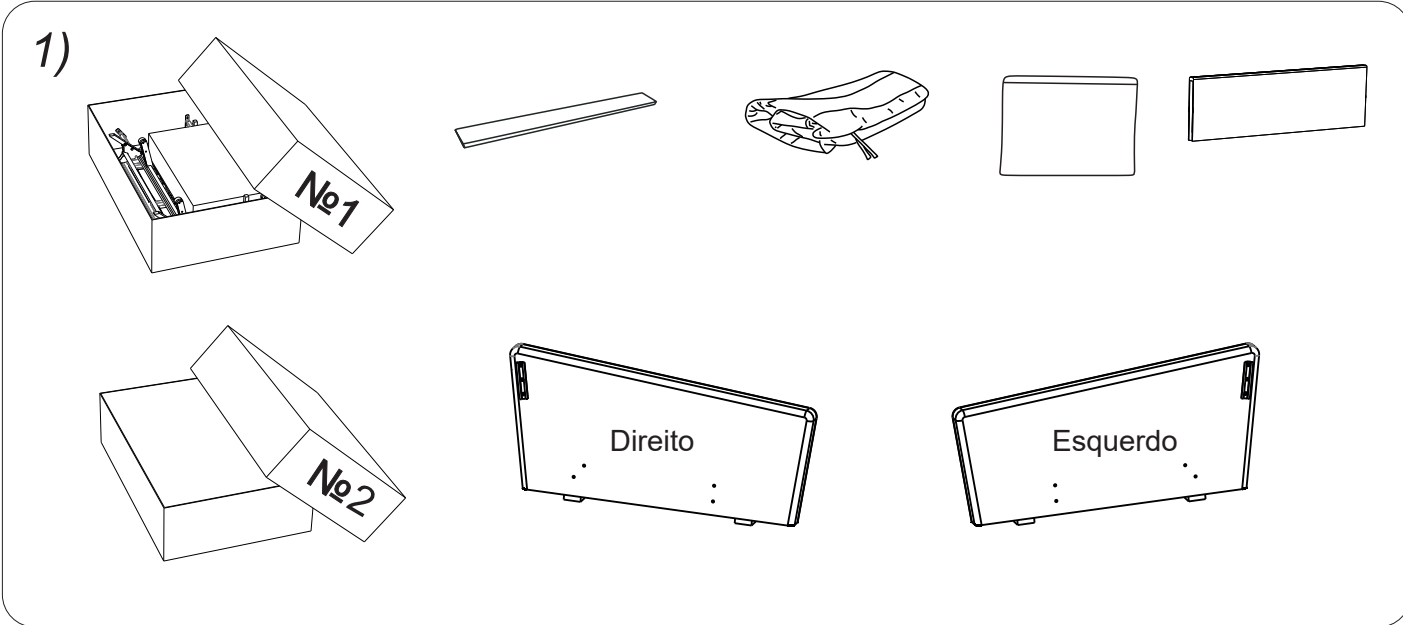

4)

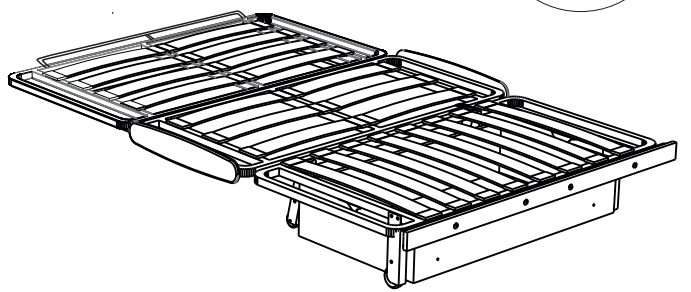
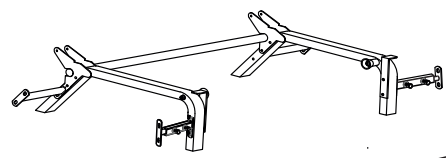
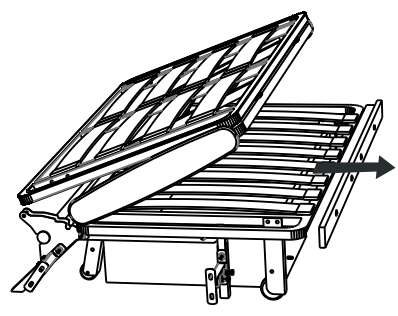

Remova a armação da cama da bancada

5)

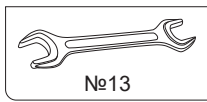
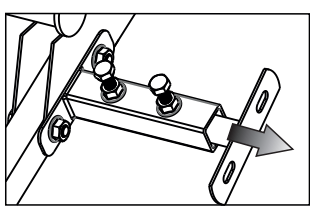
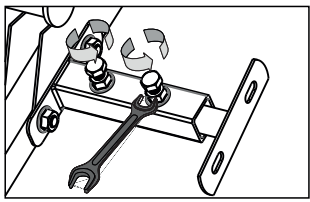

№13

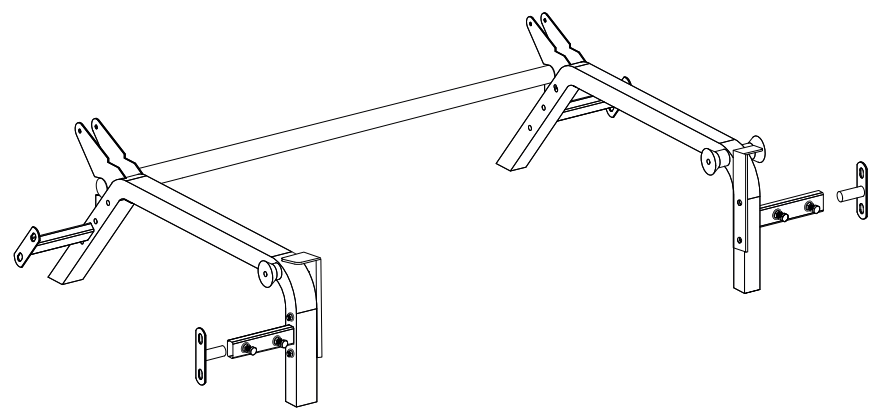

6)

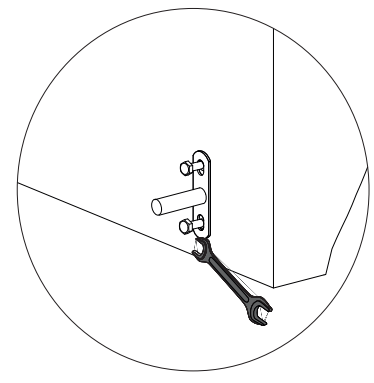
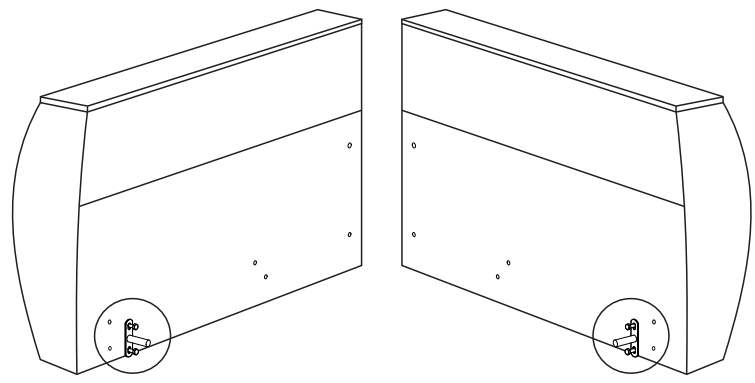

DF56

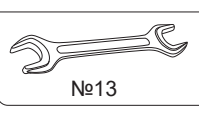

№13

Ao montar o sofá de canto, instale o suporte num apoio para o braço (do lado oposto ao sofá)

7)

Não aperte os parafusos dos suportes completamente

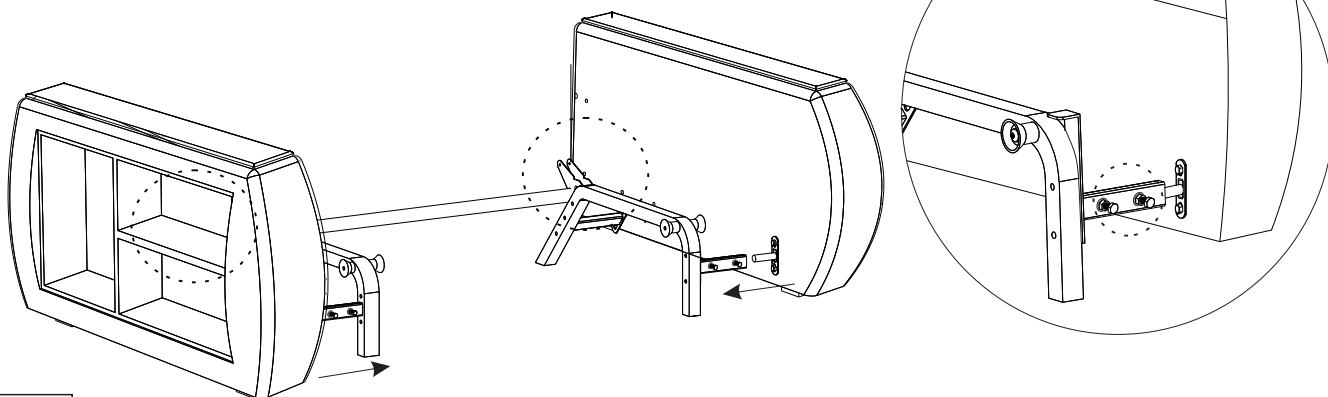

Aparafuse os suportes traseiros.  
Não aperte os parafusos dos  
suportes frontais

8)

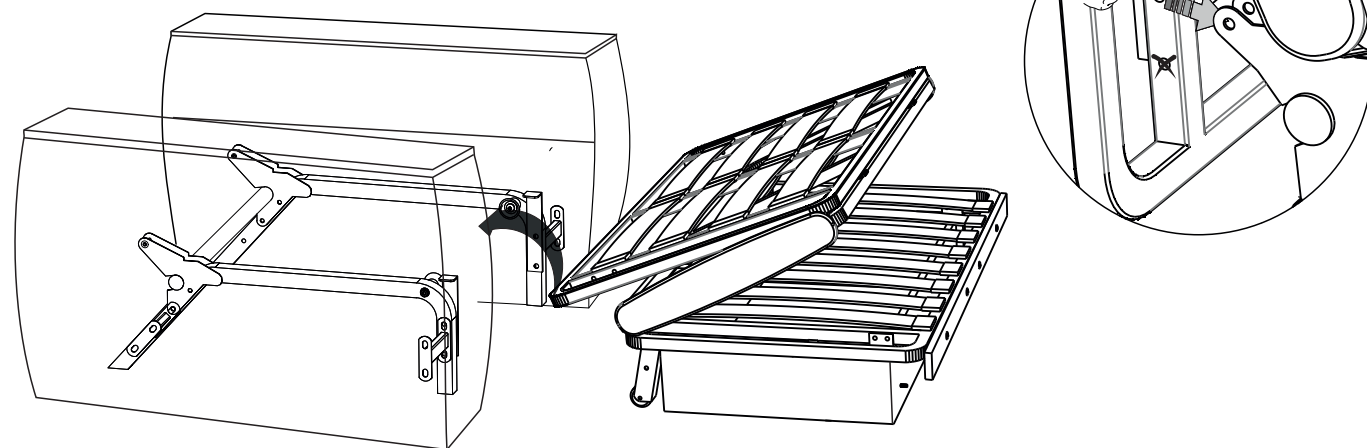

9)

Não aperte muito apertado

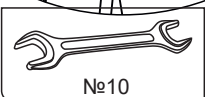
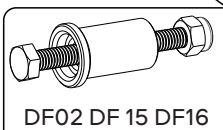
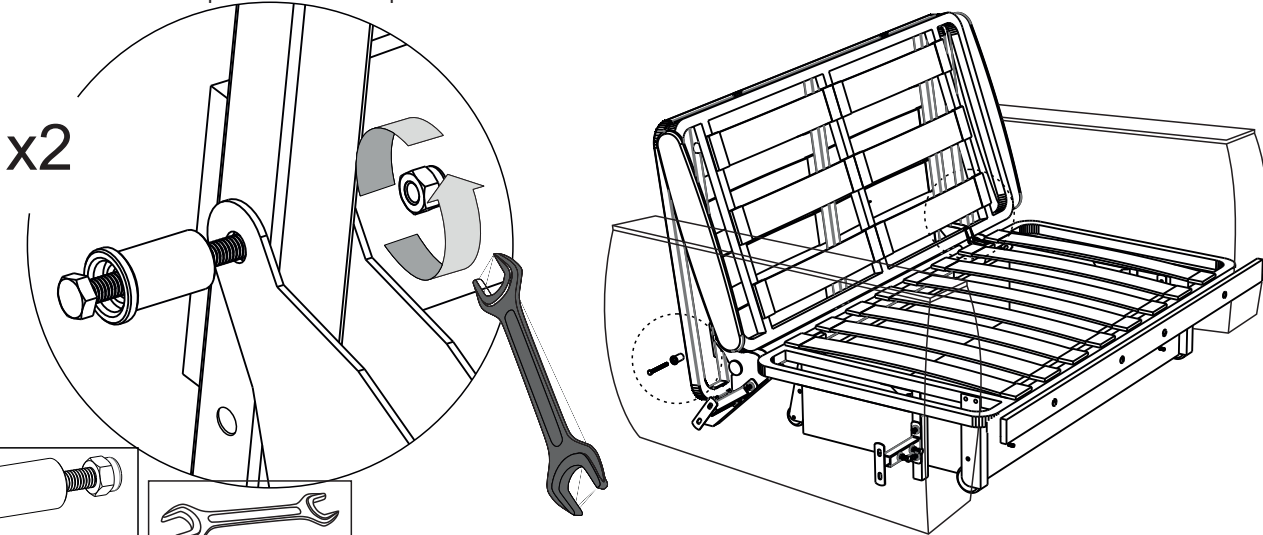

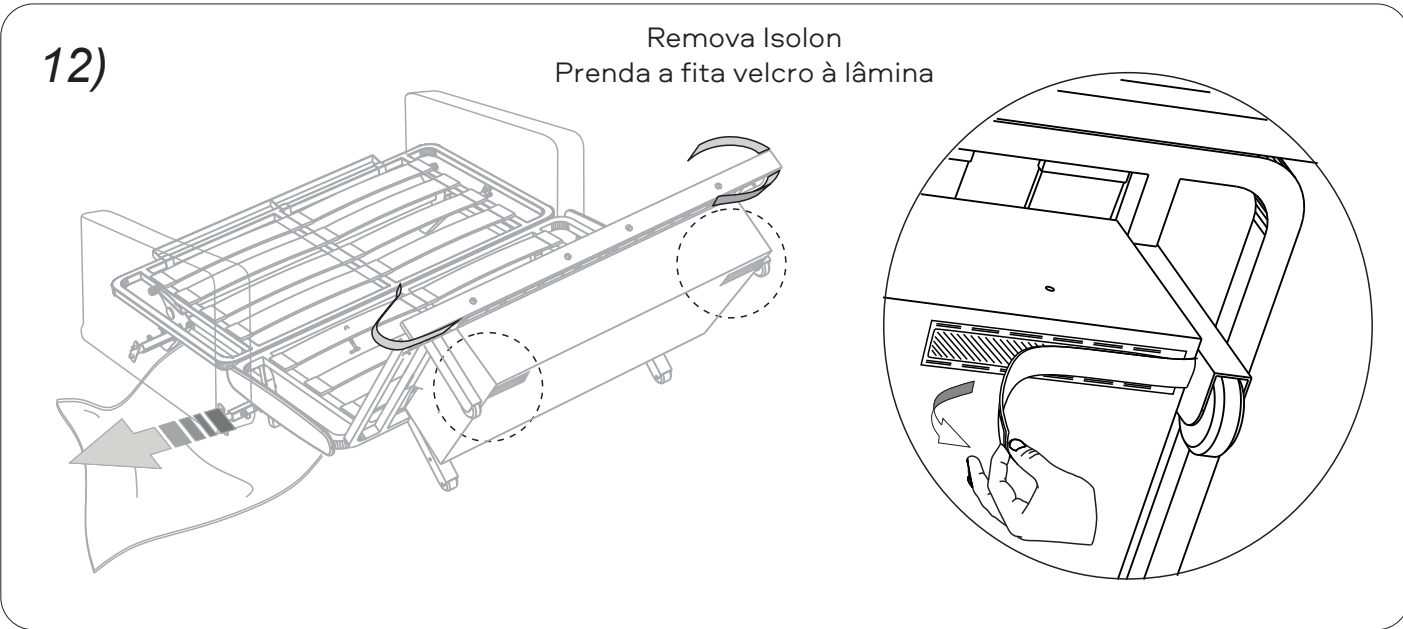
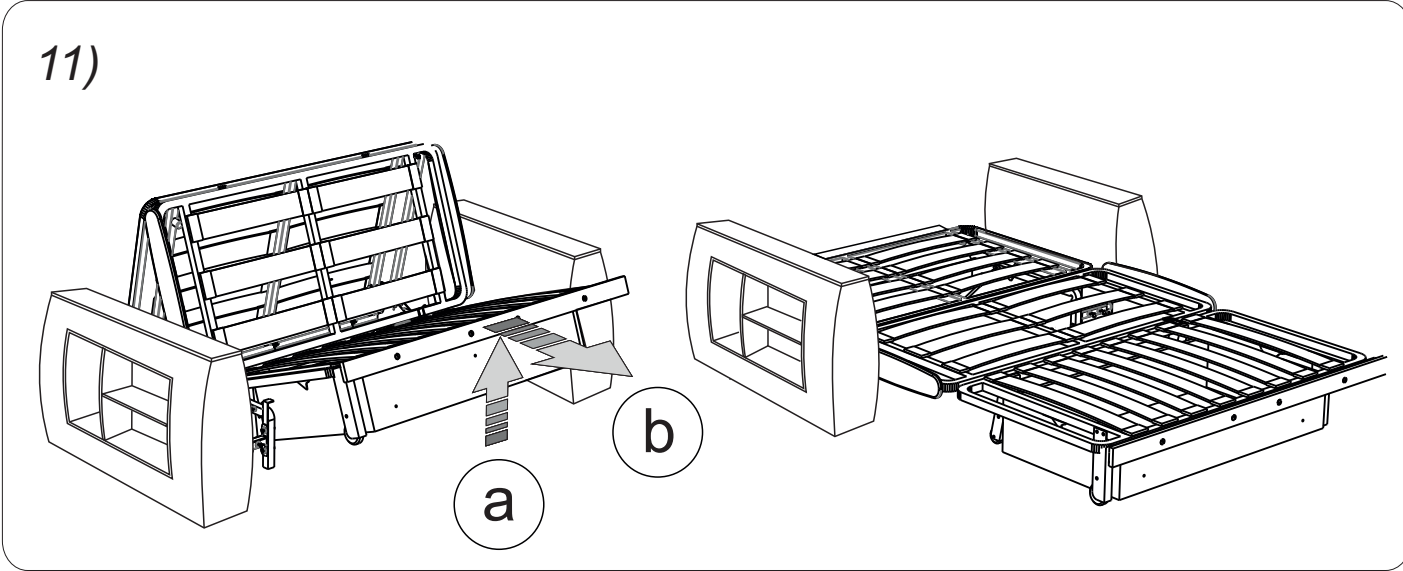
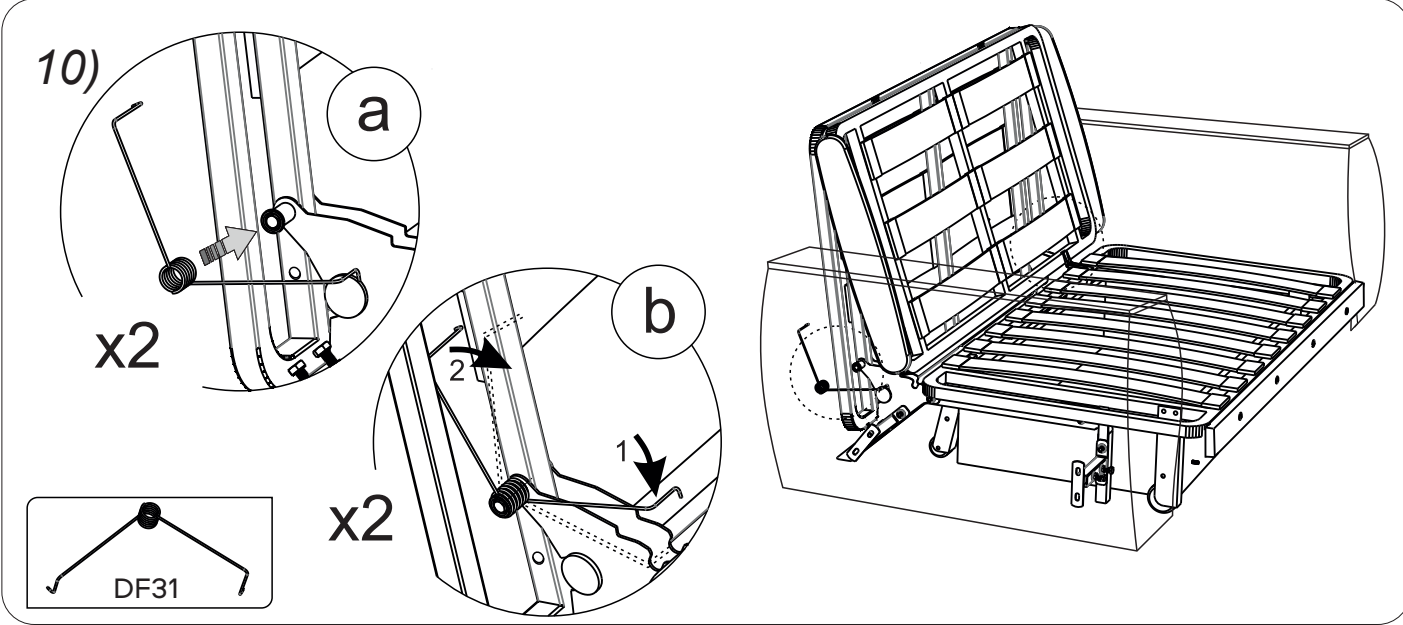



13)

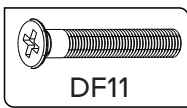
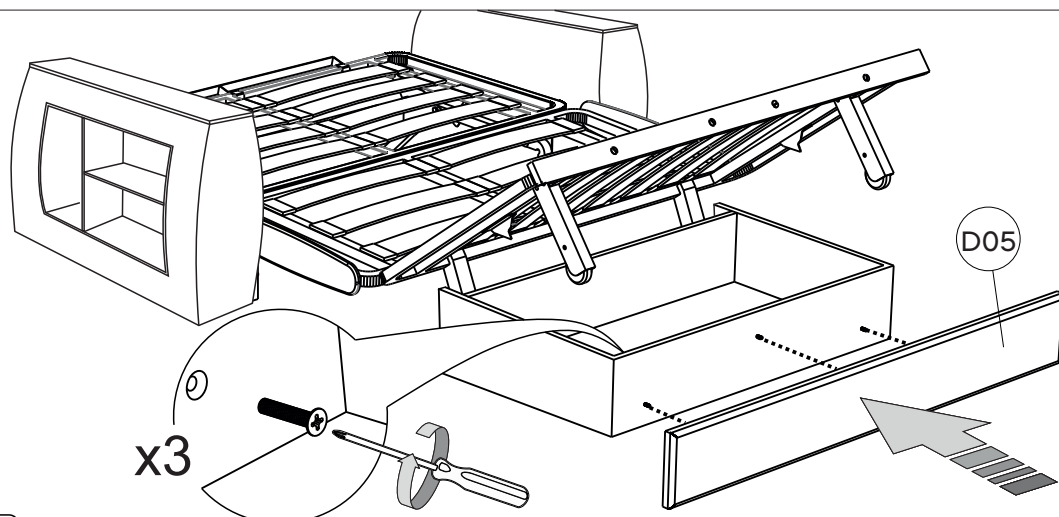

O fundo da barra lateral é determinado pela presença de uma faixa para braçadeira

14)

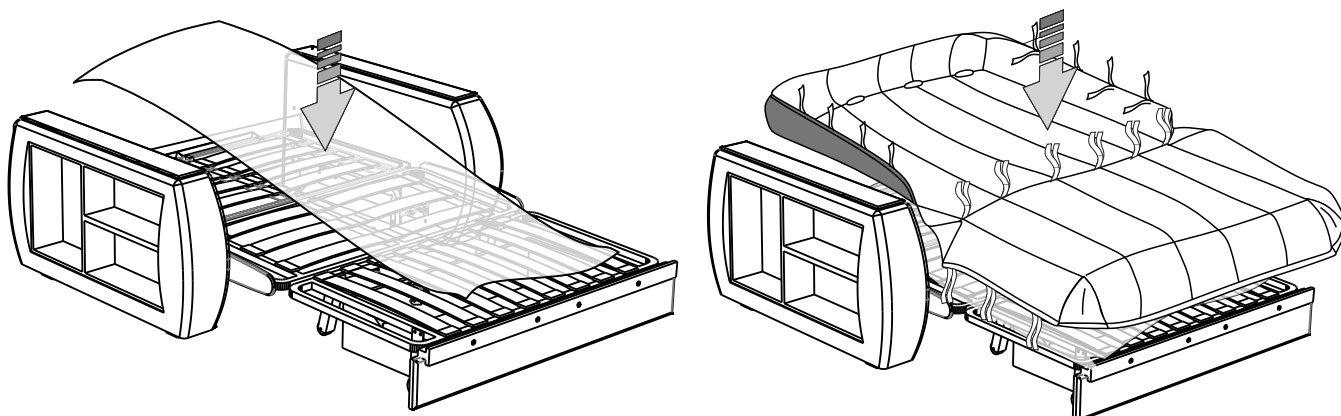

Coloque o filme de embalagem no mecanismo do sofá para proteger a capa do lubrificante

15)

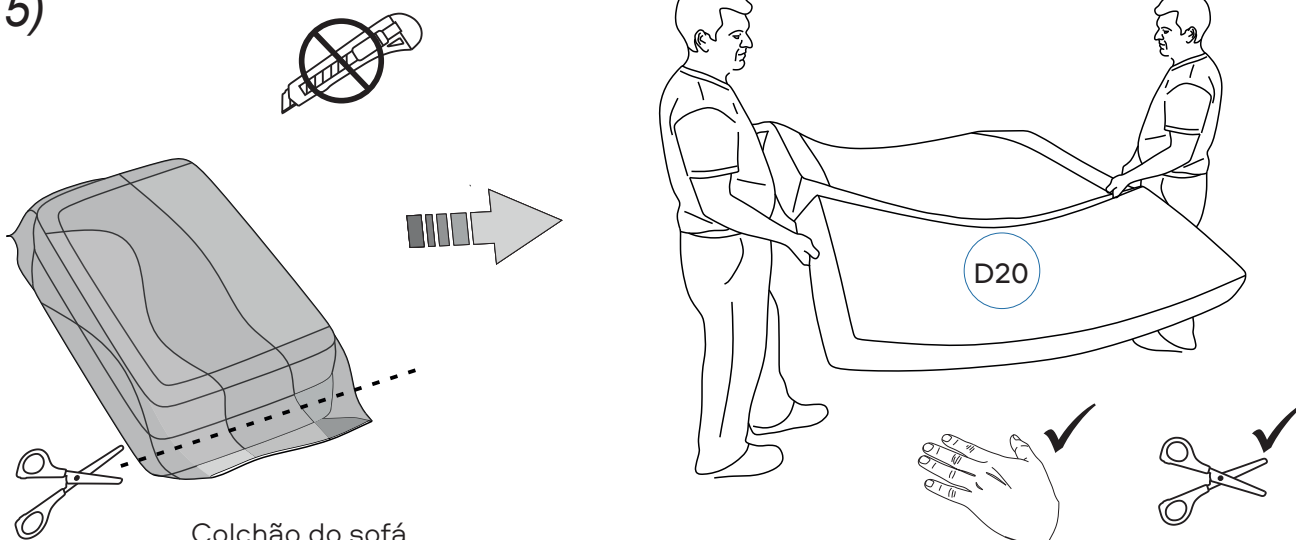

Colchão do sofá

16)

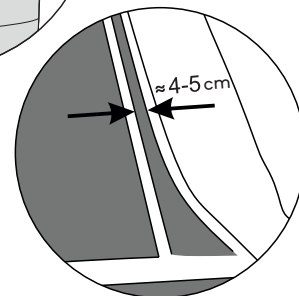
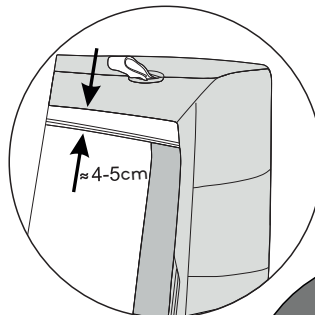
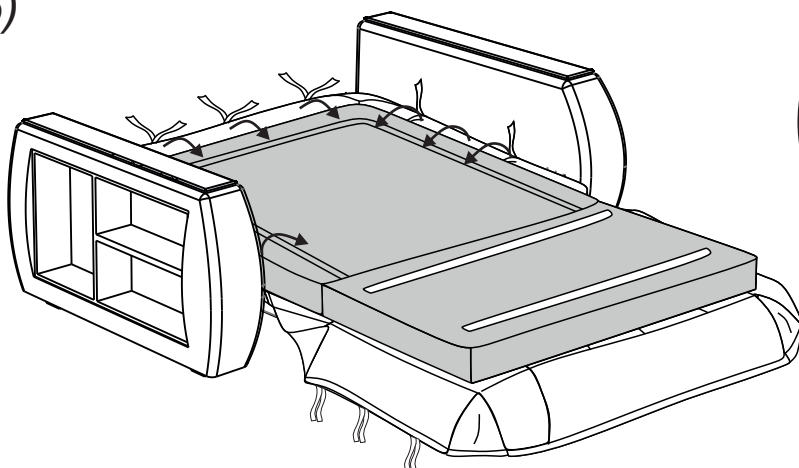

Alinhe as costuras e os cantos do colchão e da capa.  
Na cabeceira da cama, passe as fita velcro no orifícios da capa.

17)

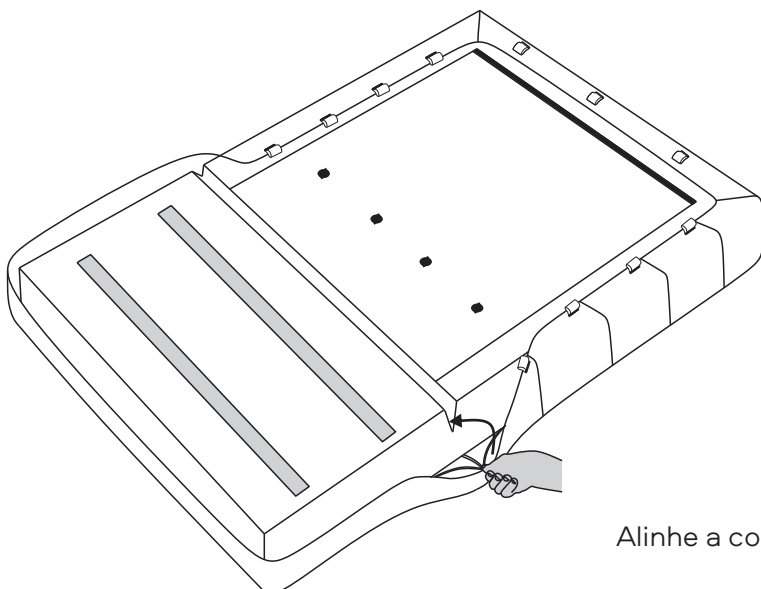

Alinhe a costura da capa e do colchão

18)

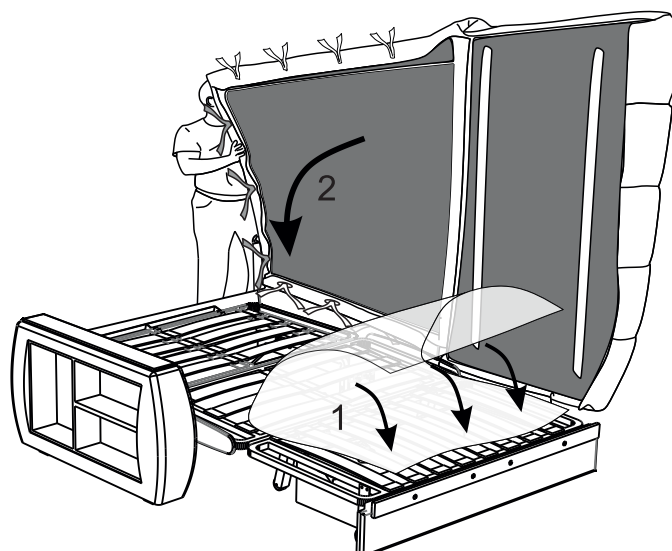

19)

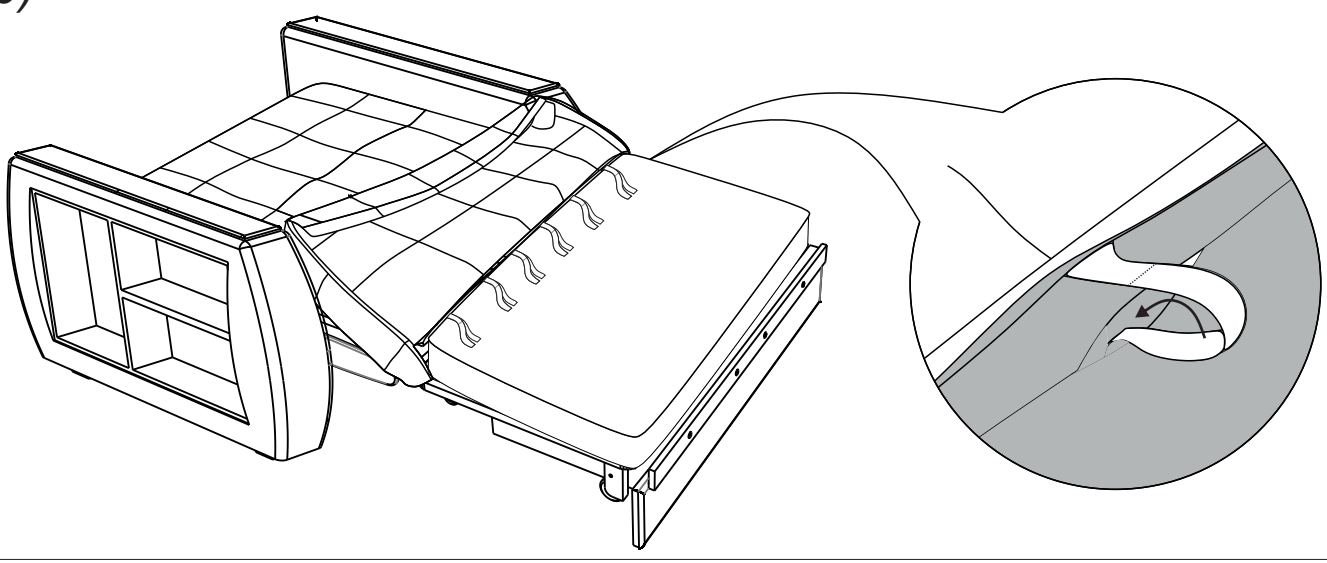

20)

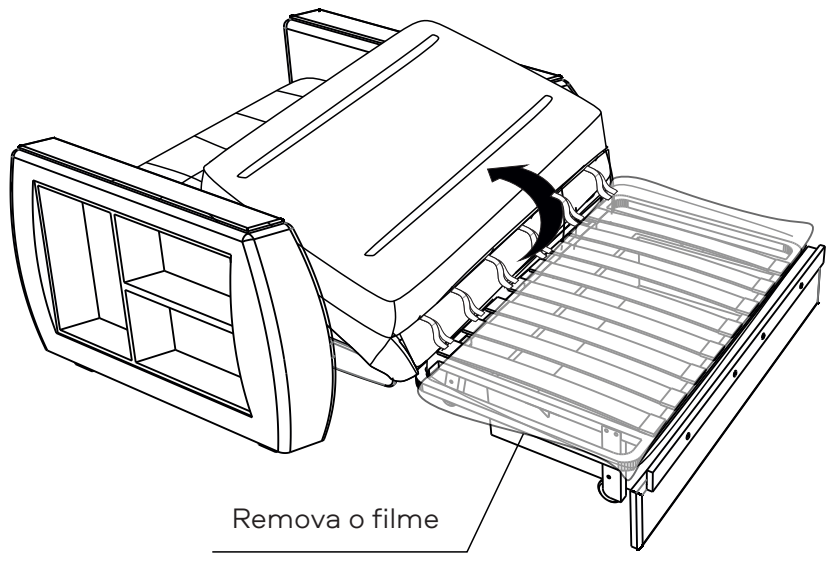

Remova o filme

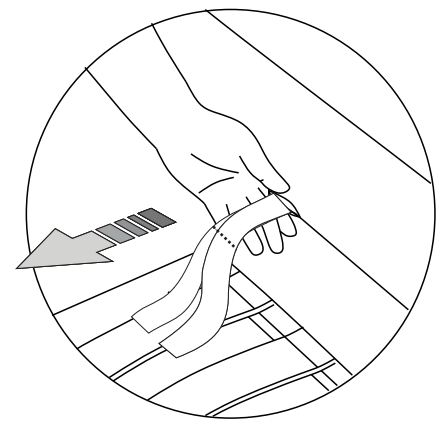

21)

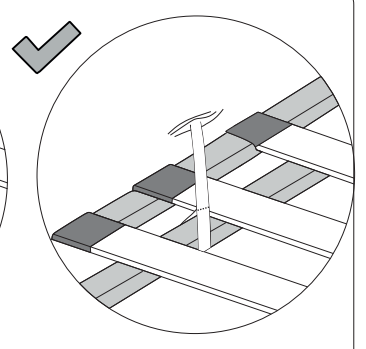
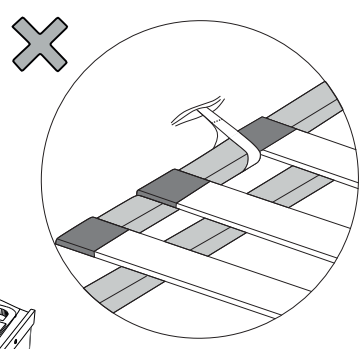
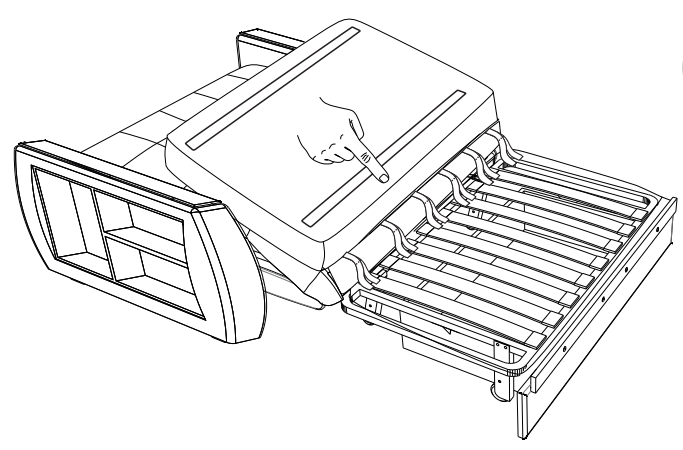

Enganche as fitas velcro firmemente até a linha de sobreposição

22)

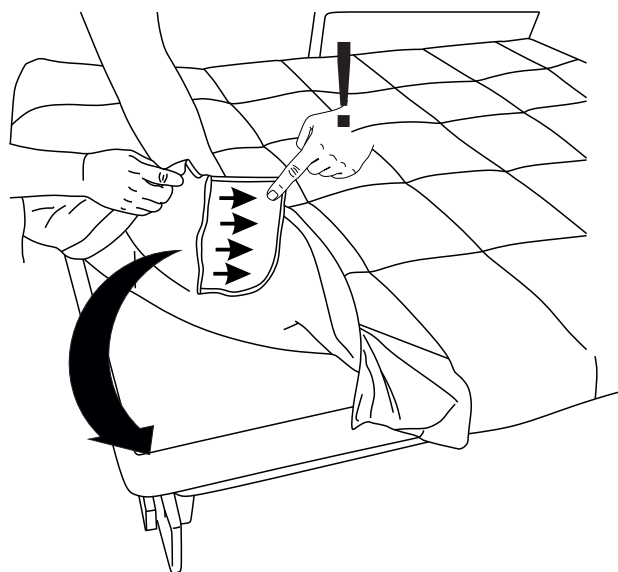
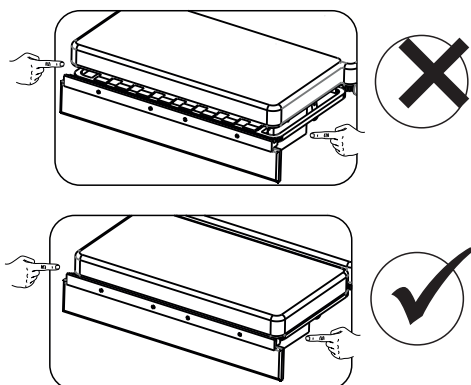

O colchão não deve se projetar mais do que 1 cm pela borda da lâmina

23)

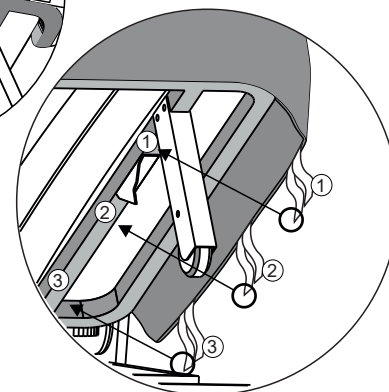
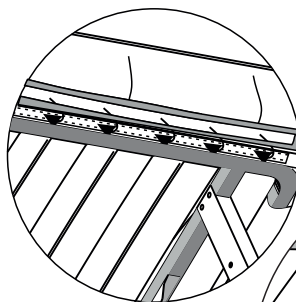
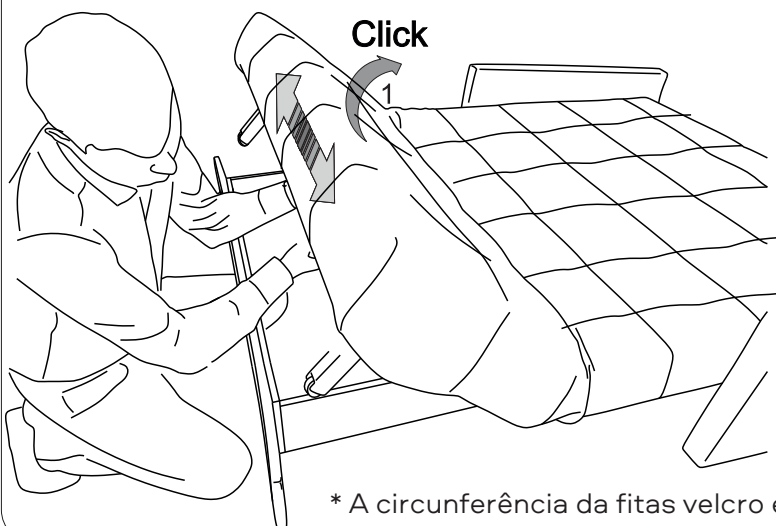

\* A circunferência da fitas velcro é um anel complet

24)

Recolher a parte em excesso do capa no ponto da dobra do colchão para facilitar a transformação

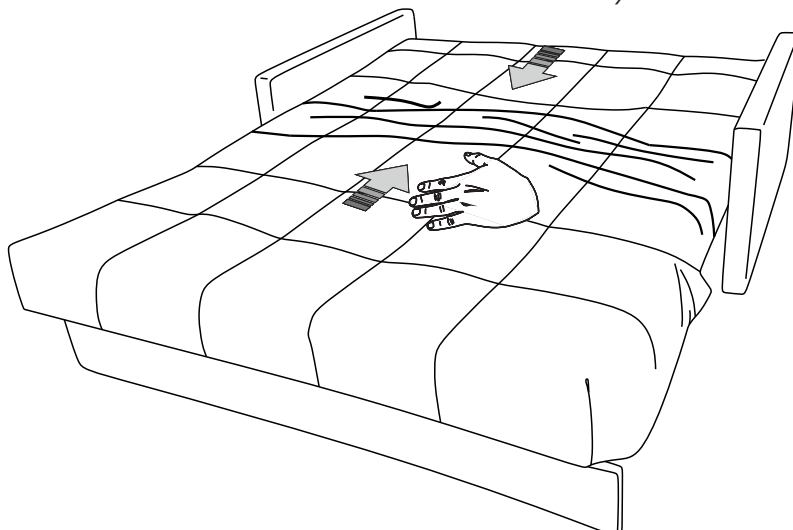

25)

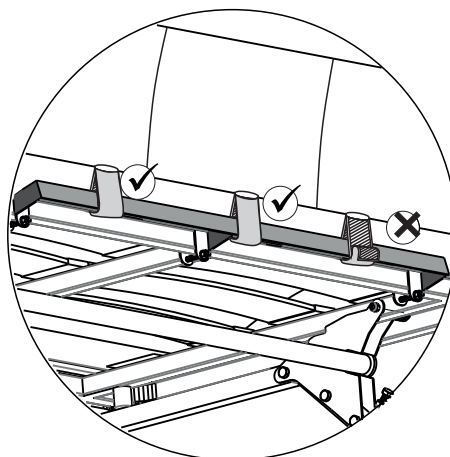
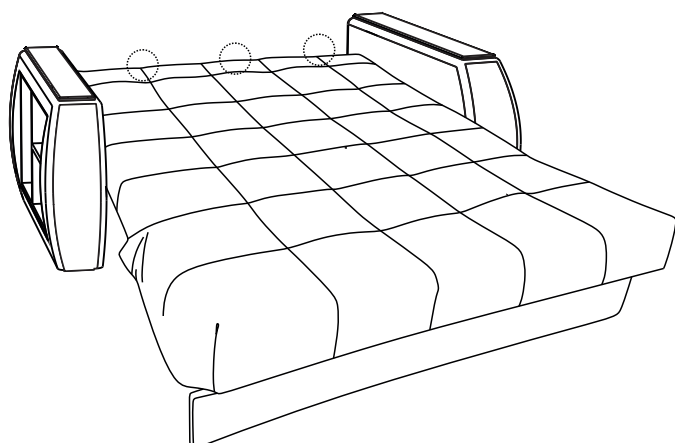

26)

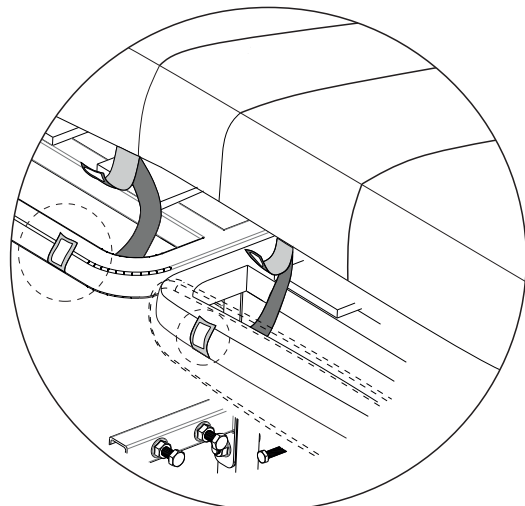
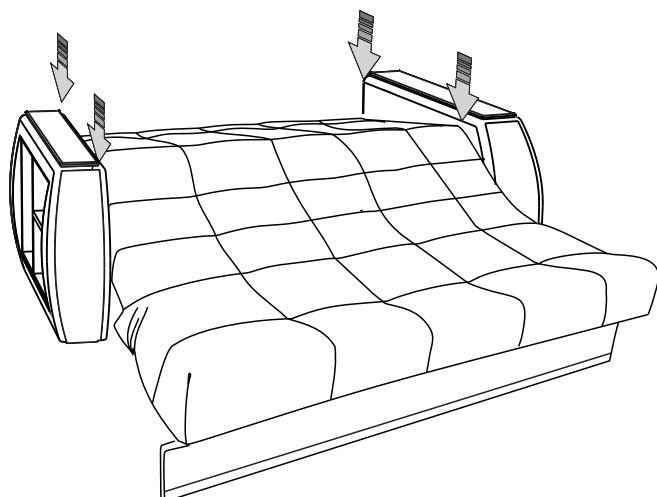

Transforma o sofá em estado semi-desdobrado.  
Ao fixar, as fitas velcro devem ser apertadas tanto quanto possível

27)

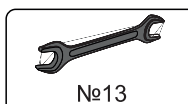
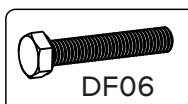
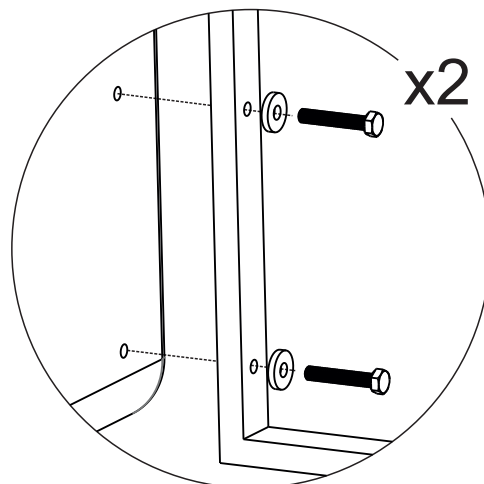
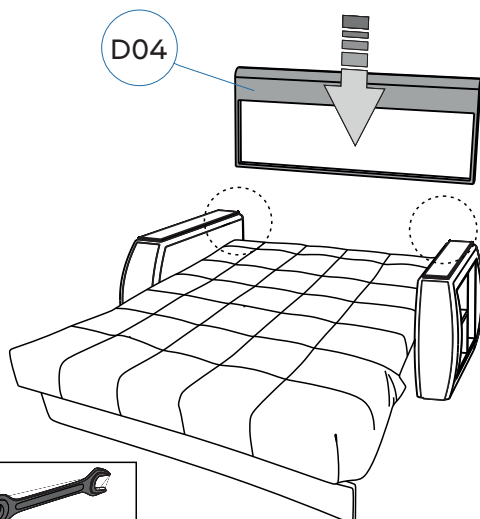

Se houver canapé, proceda à montagem do sofá de canto

28)

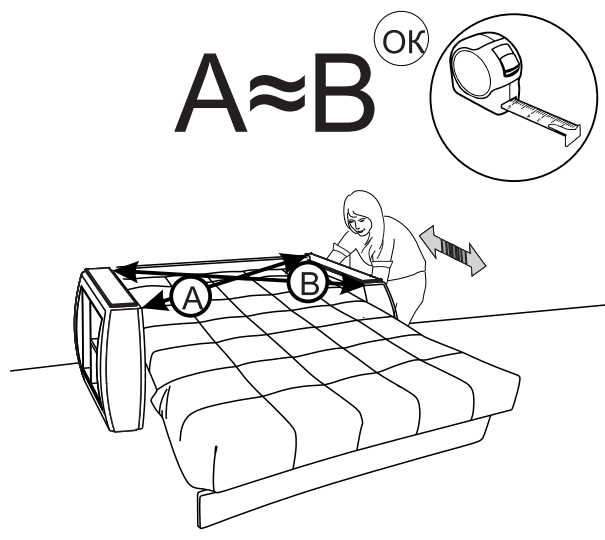
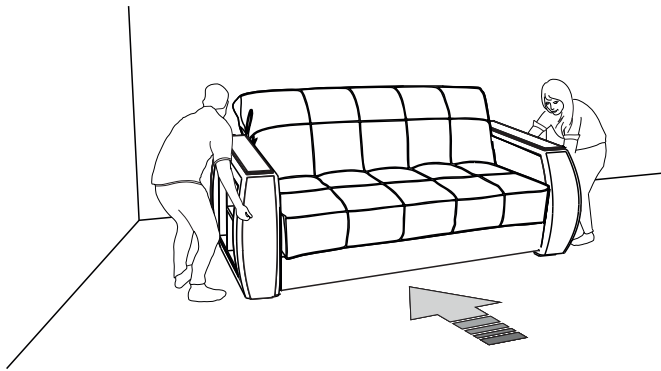

Coloque o sofá em um local de uso constante

29)

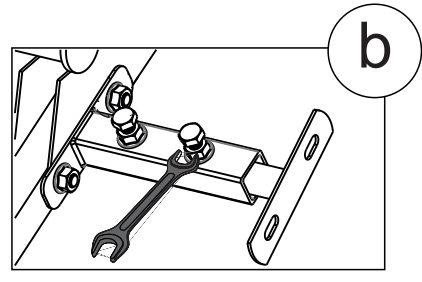
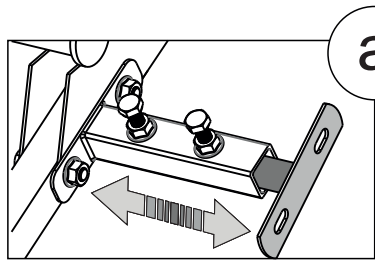
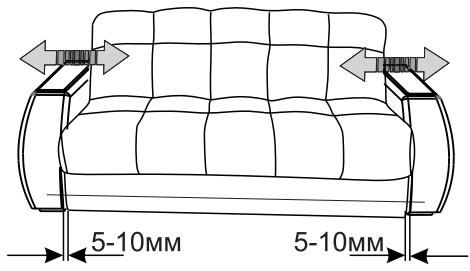

Apertar!

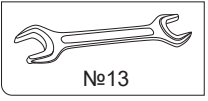

30)

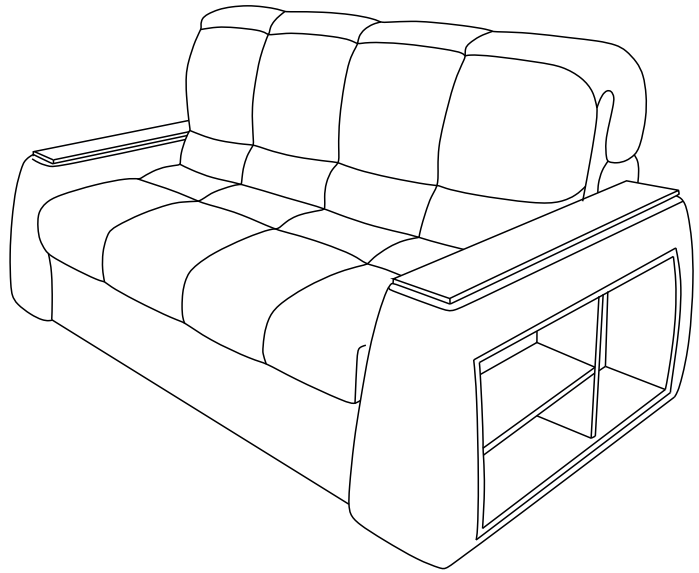



## Montagem do sofá de canto

31)

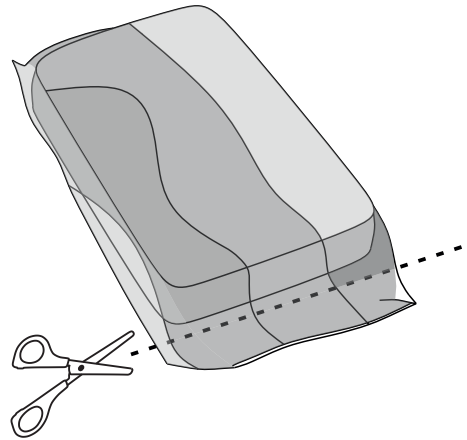
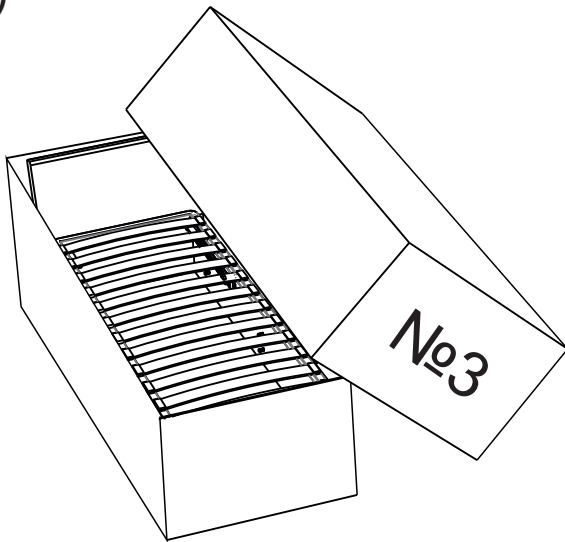

32

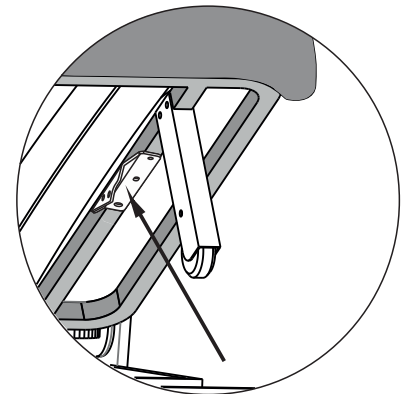
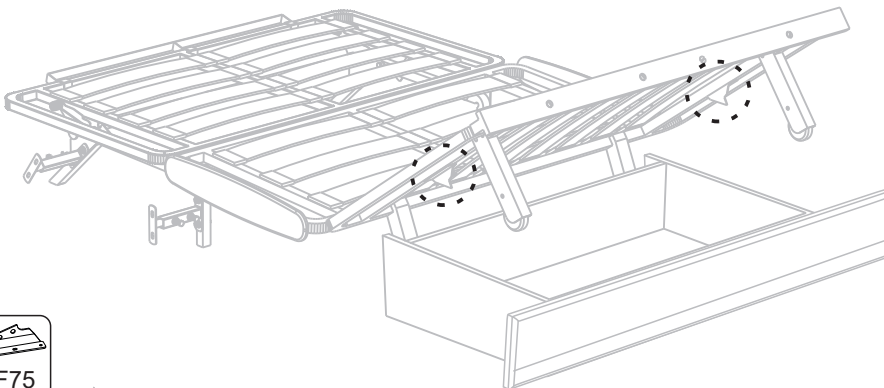

33)

As molas precisam ser instaladas apenas no canapé pequeno

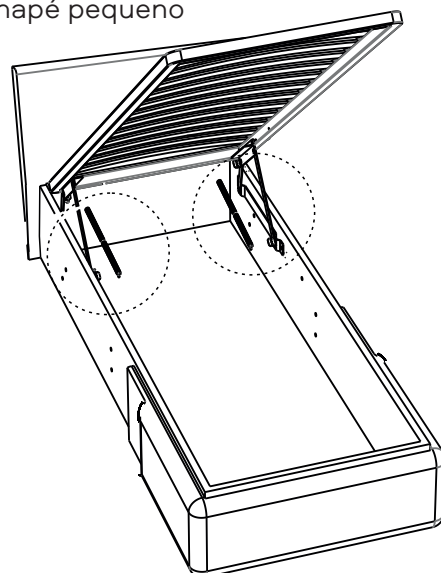
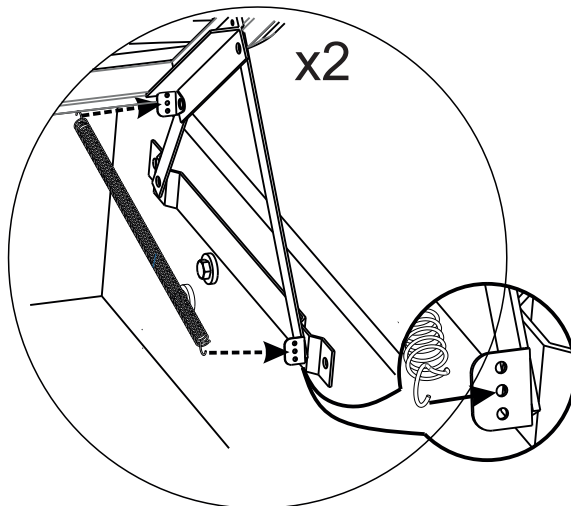



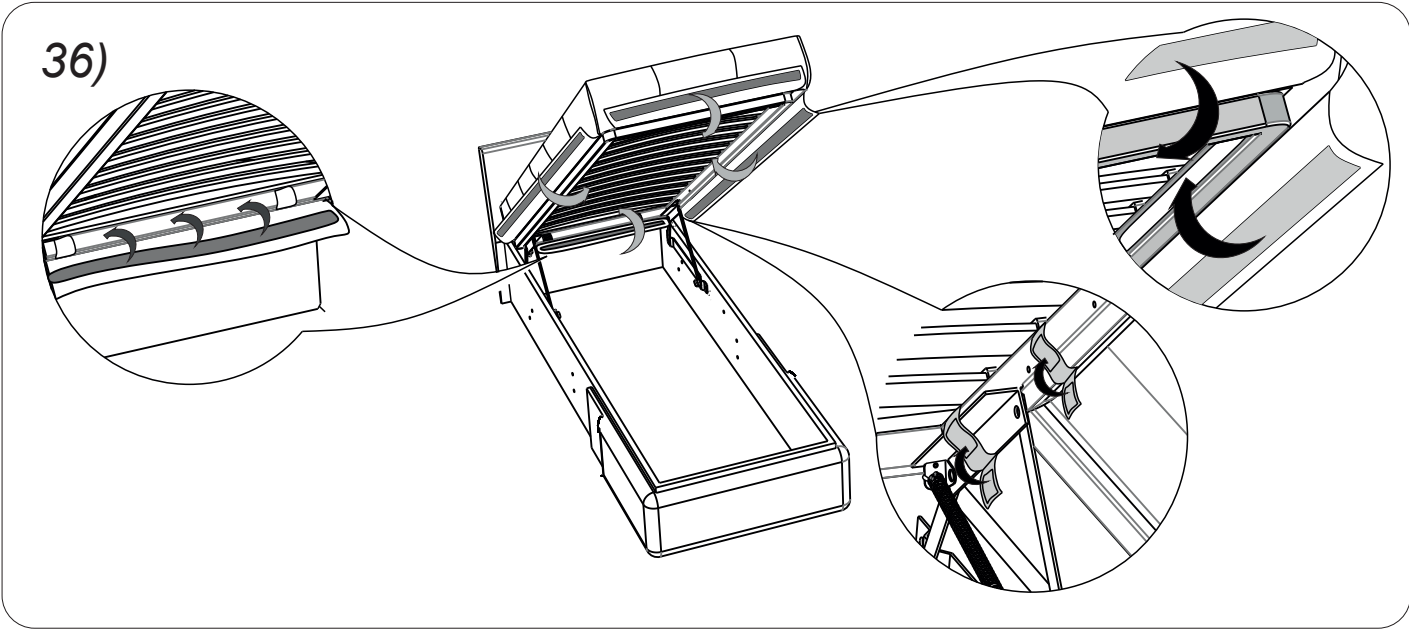
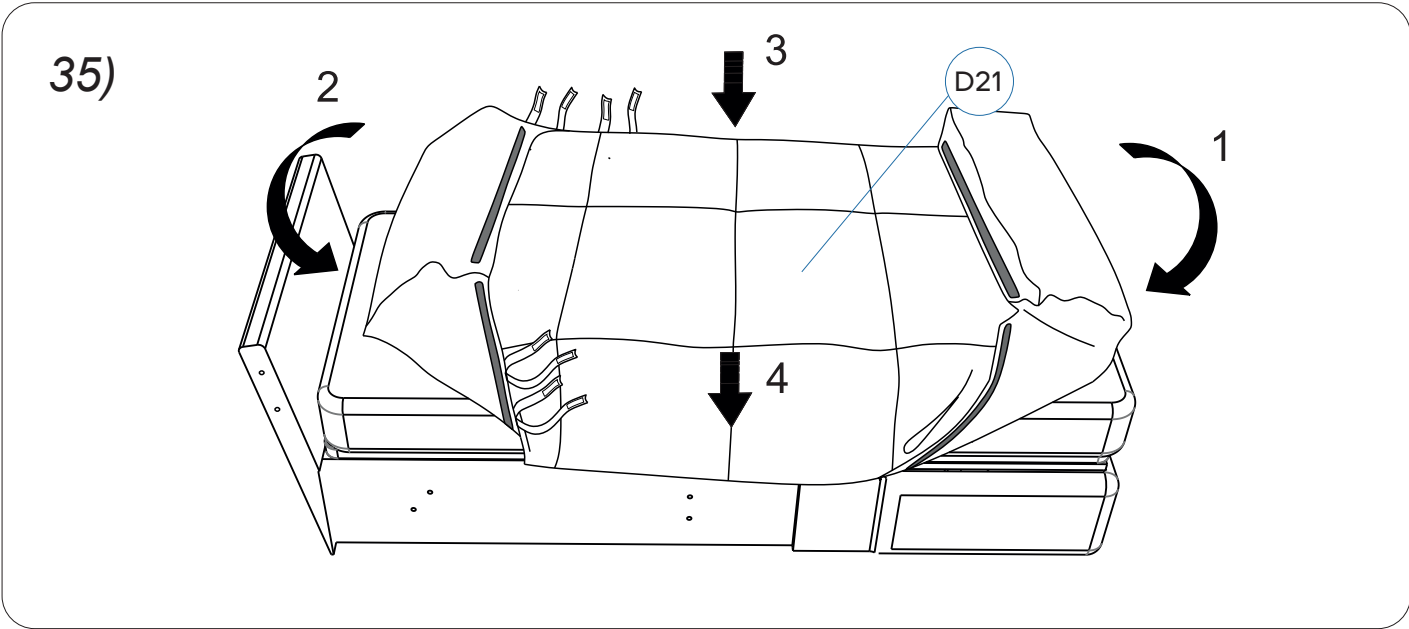
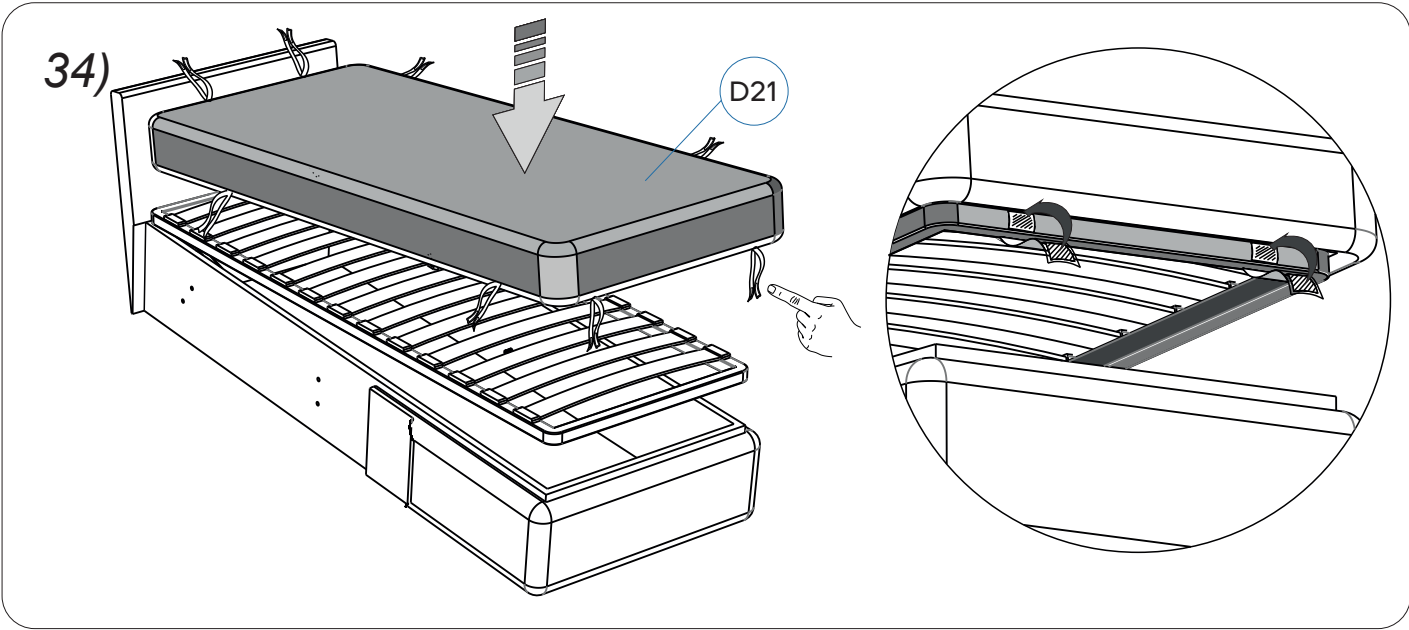

37)

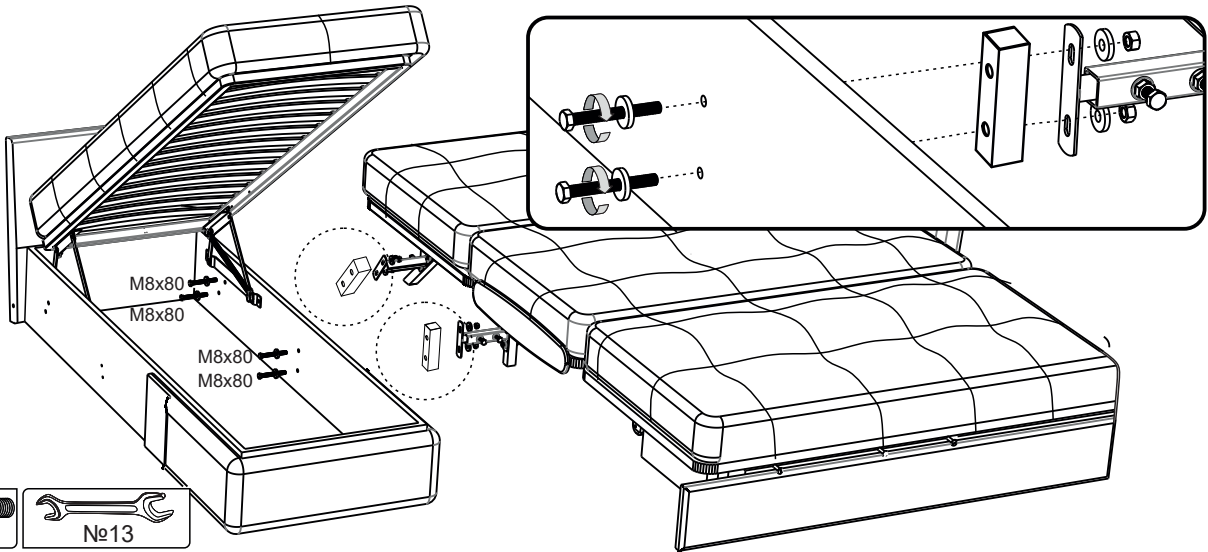

38)

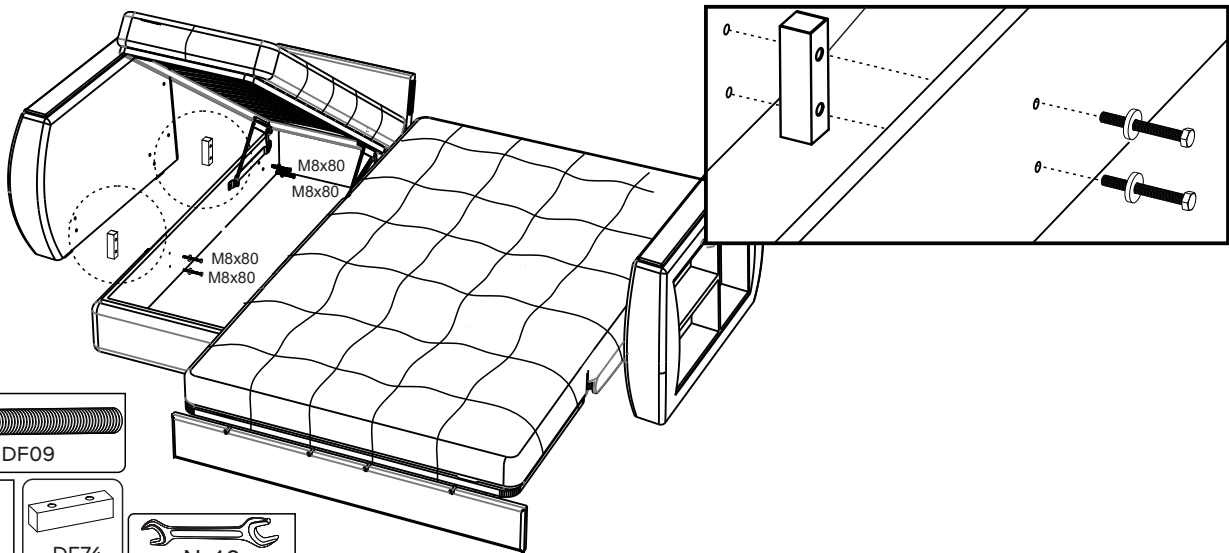

39)

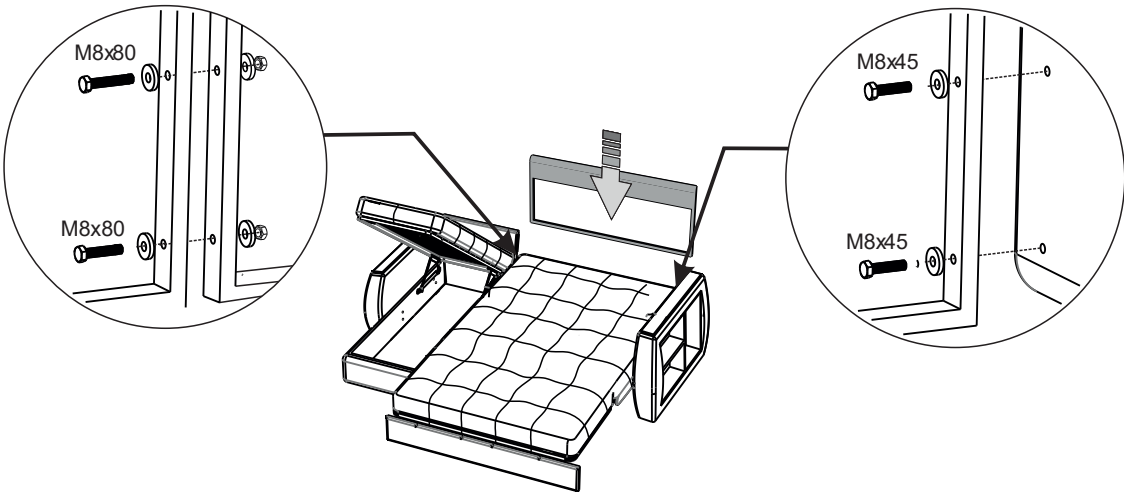

40)

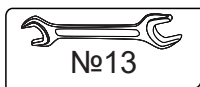
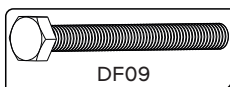
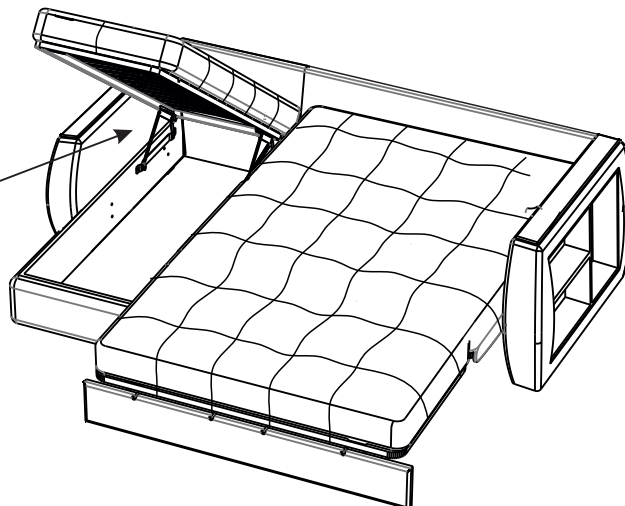
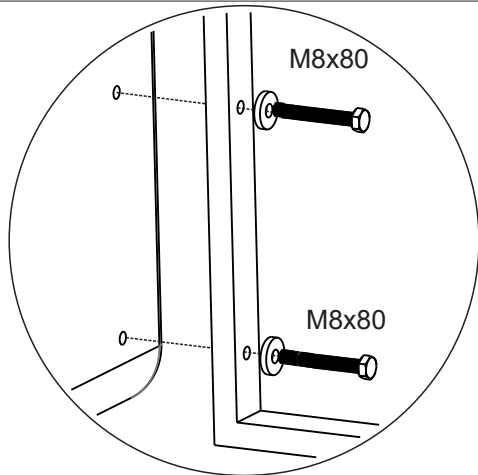

41)

1

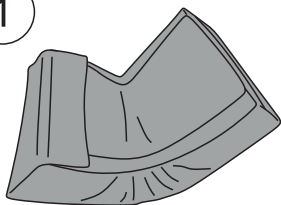

2

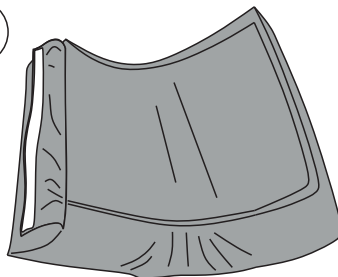

3

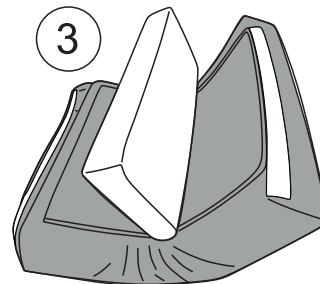

4

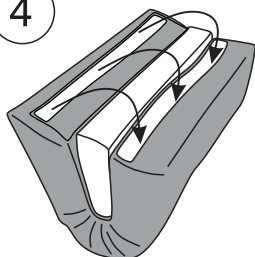

5

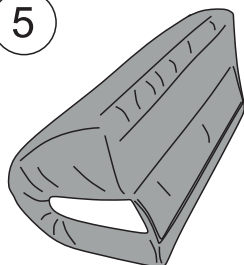

6

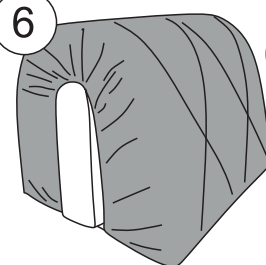

42)

b

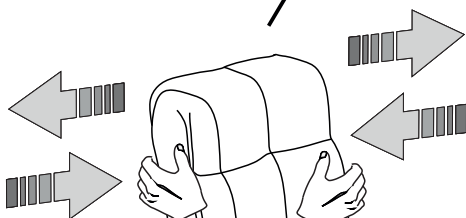

a

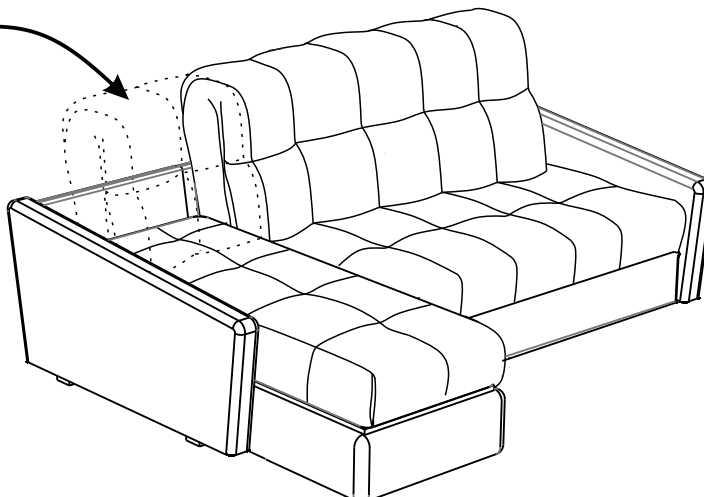

43)

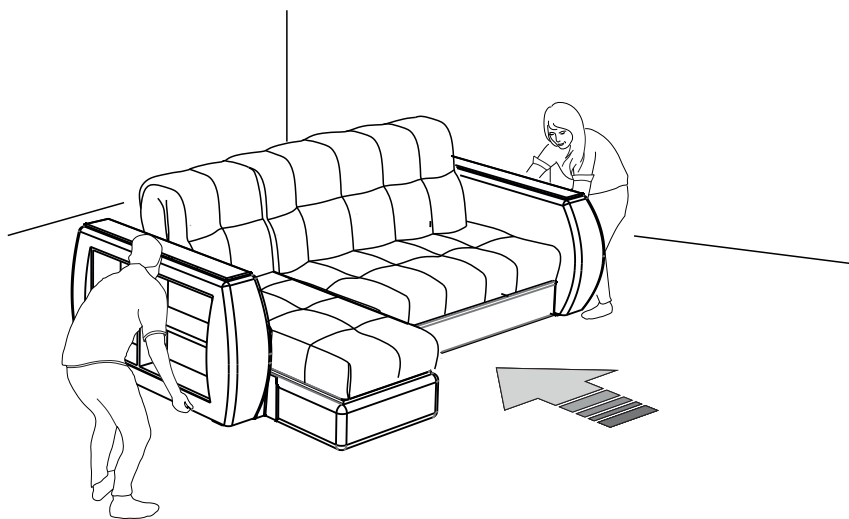

Coloque o sofá em um local de uso constante

44)

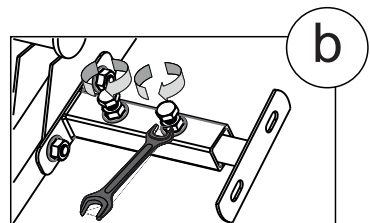
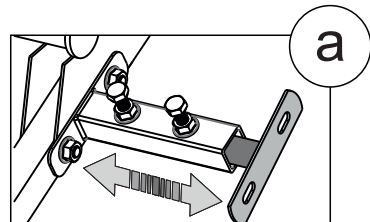
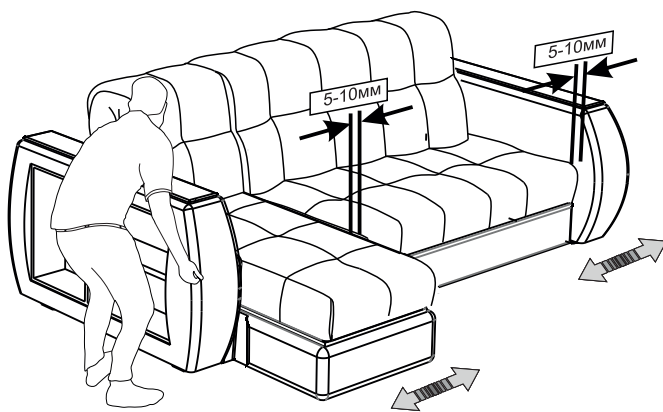

Apertar!



45)

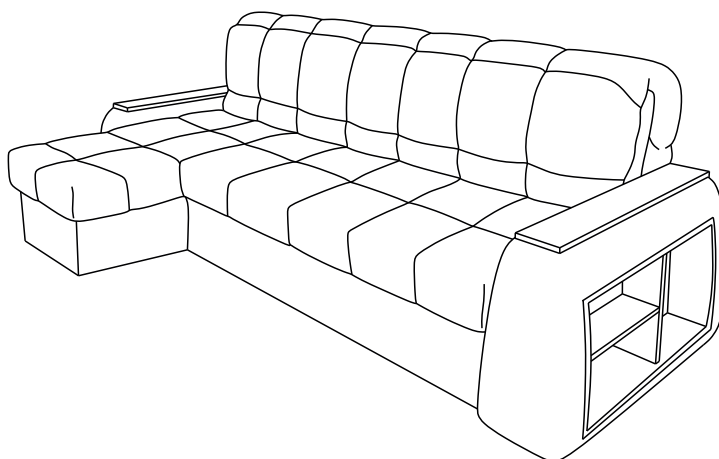

Dīvāna transformācijas kārtība

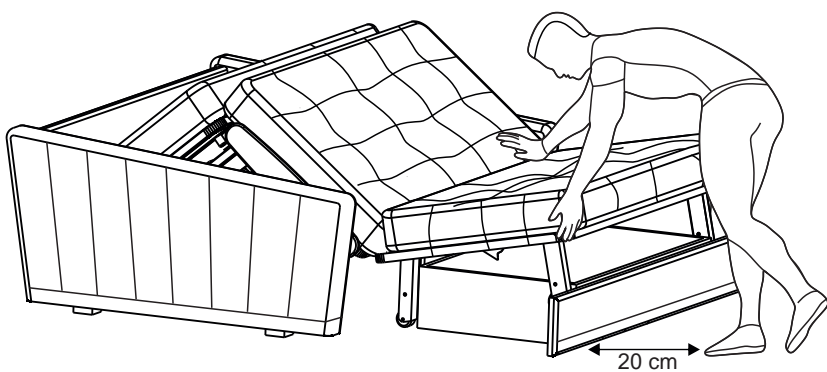
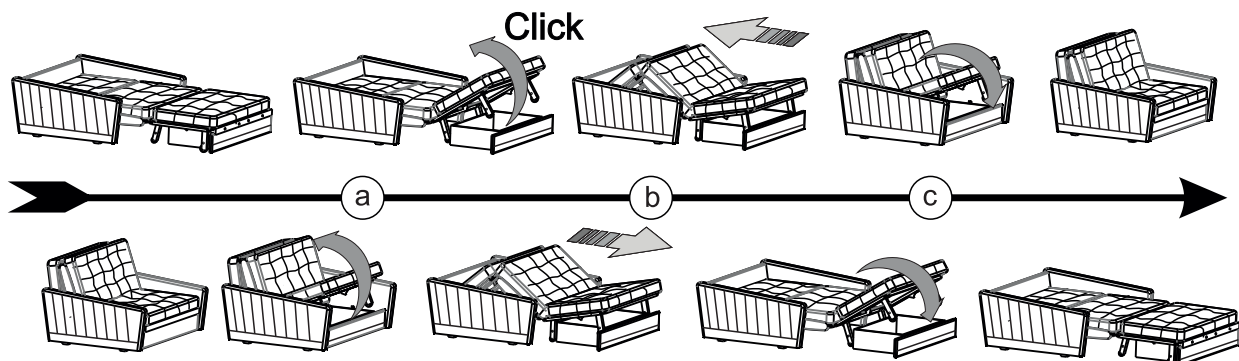

Ja dīvāna sēdekli nevar pacelt, atvienojiet transportēšanas lipenes.

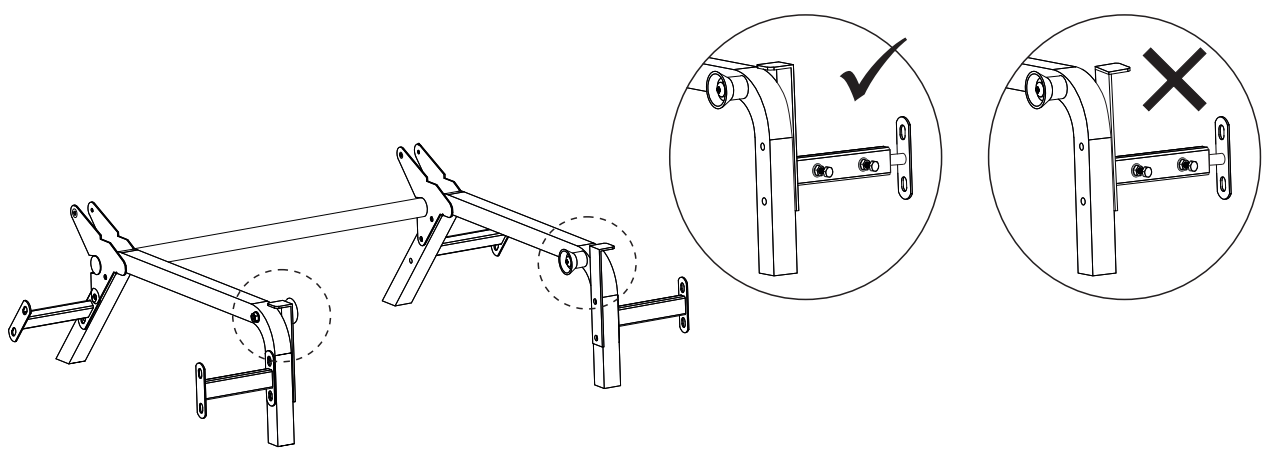

Ja dīvāna sēdekli nevar aizbīdīt, pārbaudiet mehānisma balstu pozīciju.

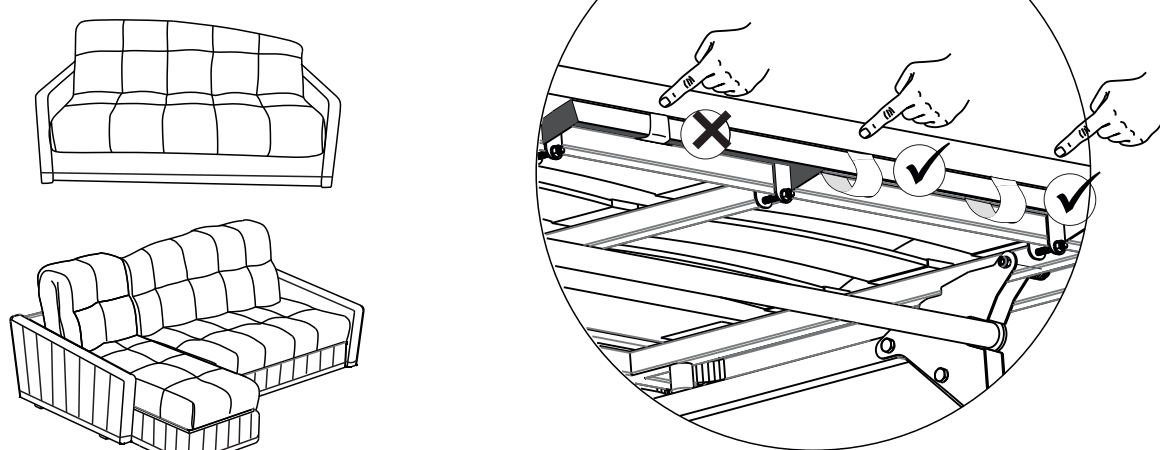

Ja dīvāna atzveltnes pozīcija ir šķība, atslābiniet kontaktlentes galvgalī

Ja starp matraci un roku balstu ir liela atstarpe, paceliet sēdekļa zonu un atslābiniet kontaktlentes

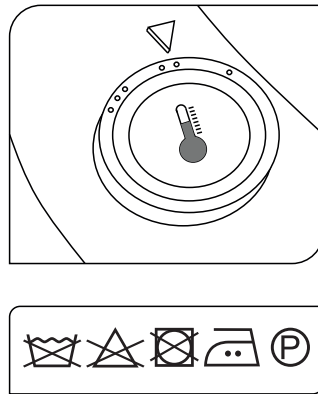
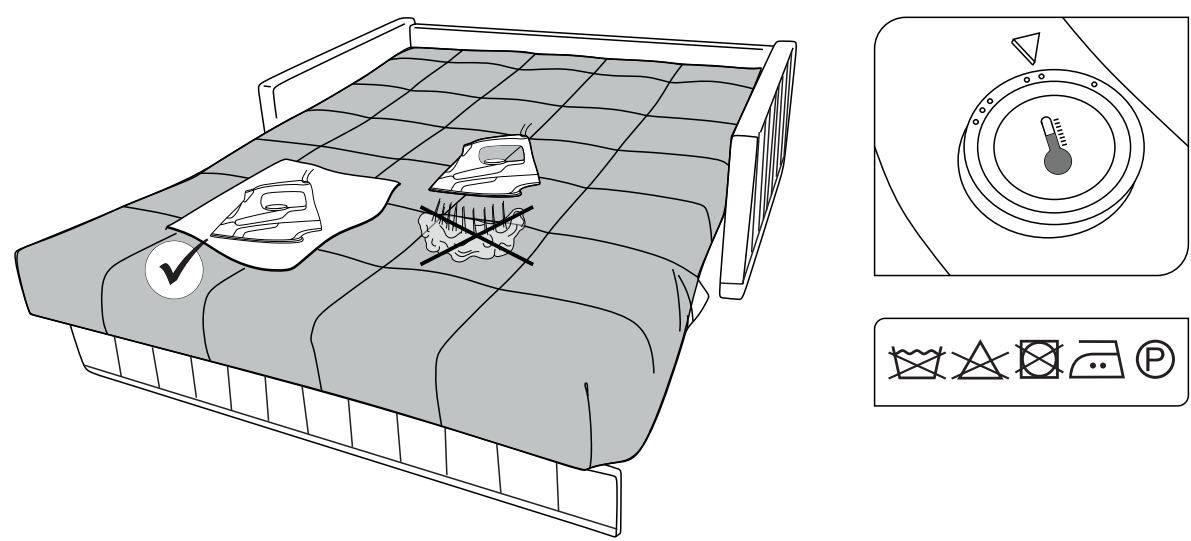
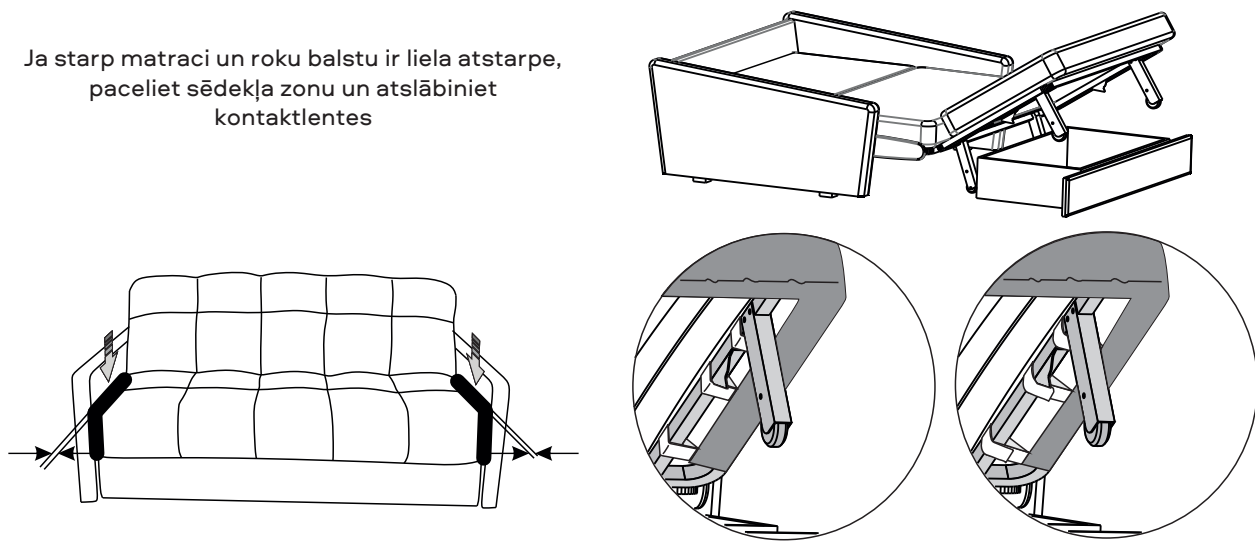



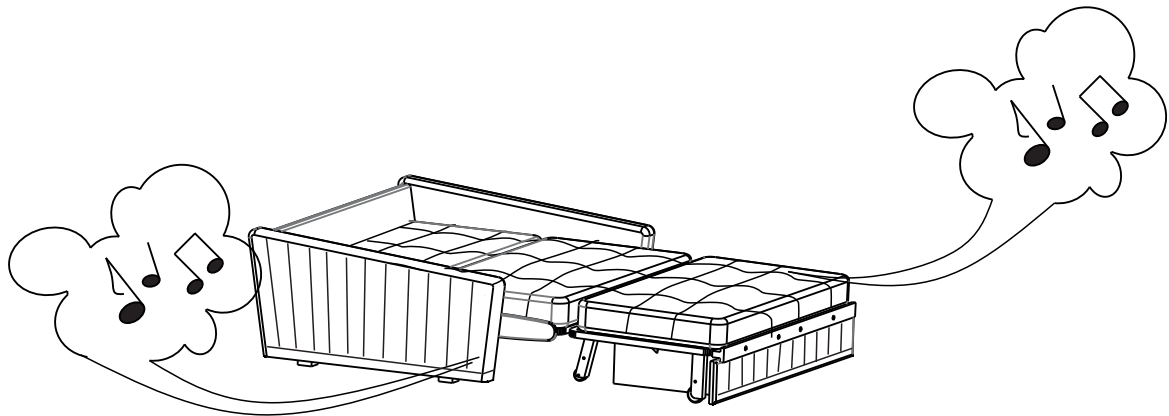

Atcerieties: mehānisma metāla elementu raksturīgā čīkstēšana pastāvīgas transformācijas laikā ir normāla situācija. Dīvāna centrā ir izturīga metāla konstrukcija, kas ikdienā dīvānu ļauj transformēt par gultu. Transformācijas un darbības laikā smērviela starp dažādām mehānisma daļām var izžūt un parādās metāla elementu berze vienam pret otru. Lai izvairītos no šīs berzes rašanās un mehānisma čīkstēšanas transformācijas vai darbības laikā, svarīgi ievērot ražotāja ieteikumus. Mehānisma čīkstēšanas gadījumā berzes elementi ir jāieeļļo

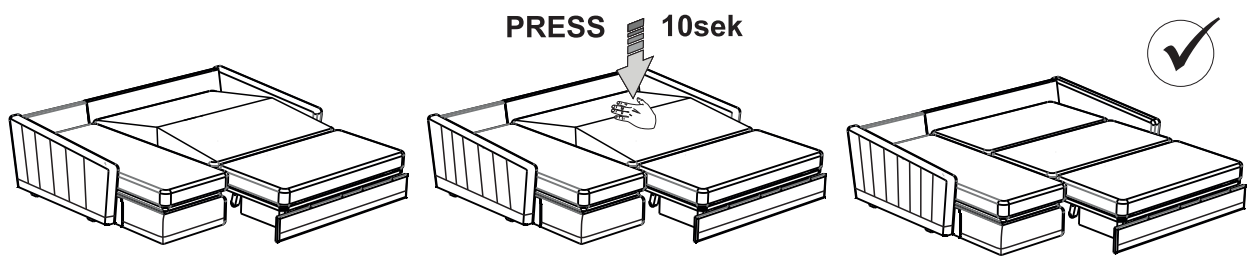
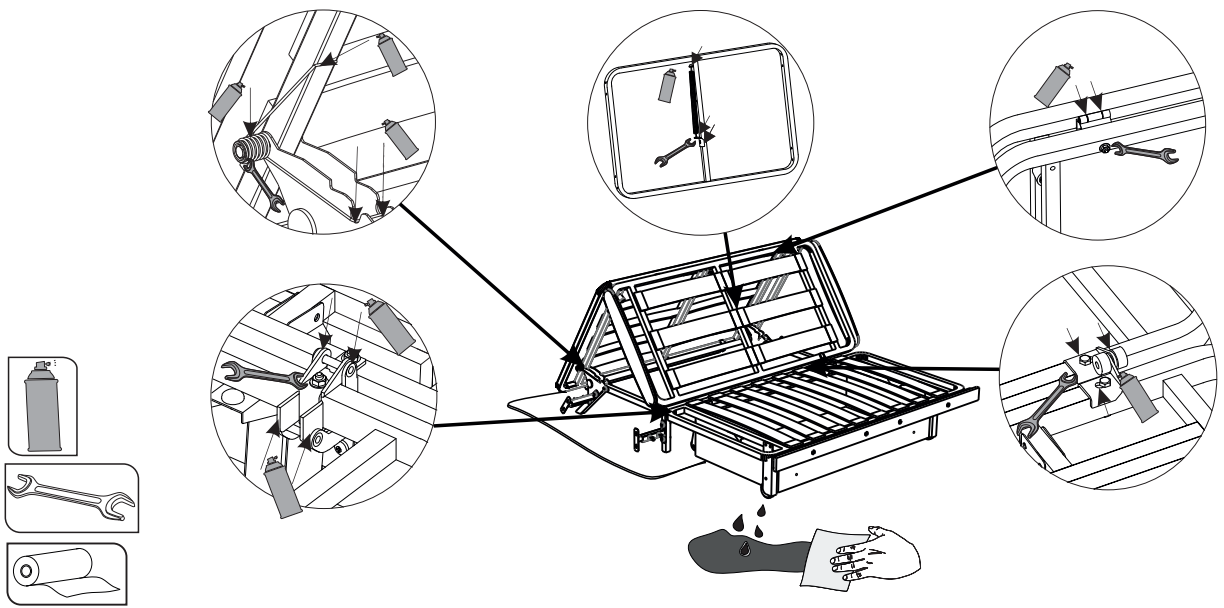







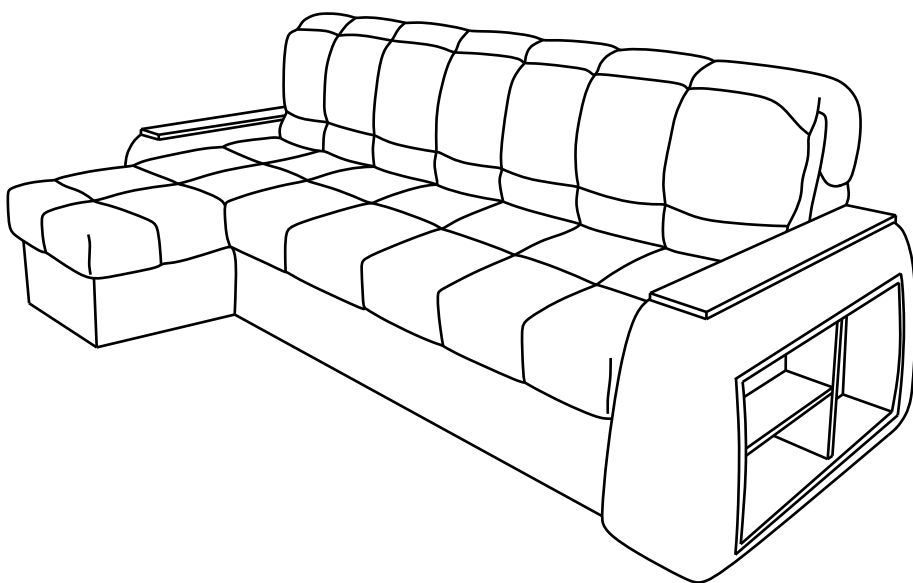
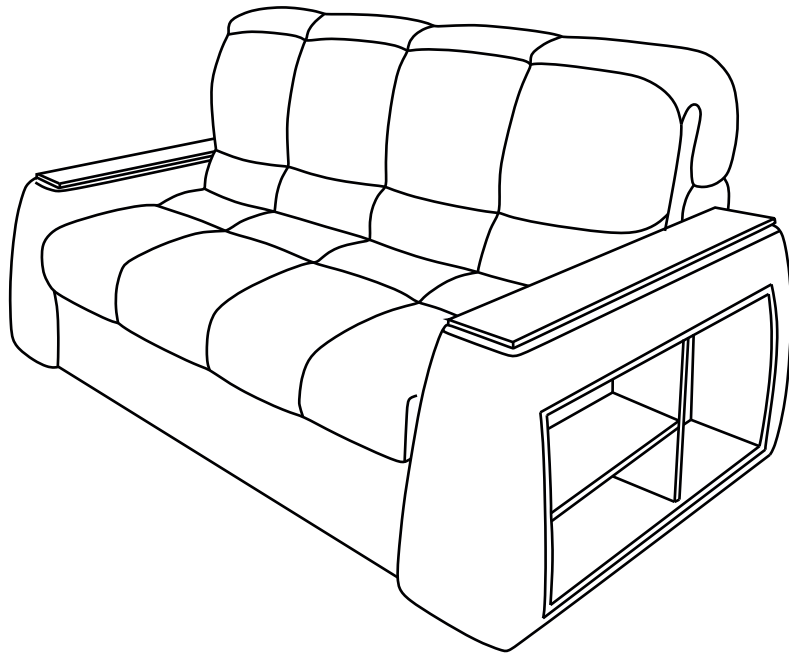



# SUNSET NOVA

LV



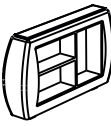
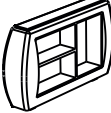
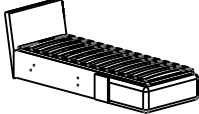

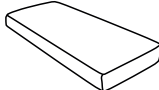

Sleep.8



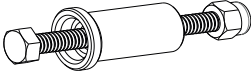
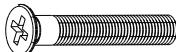

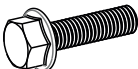
## Dīvāna komplektācija

Iepakojums	Detaļa	Artikuls	Nosaukums	Daudzums
№ 1		D01	Transformācijas mehānisms	1
		D26	Transformācijas mehānisma balsts	1
		D04	Atzveltne	1
		D05	Apaļtapa	1
		D07	Stepēts pārvalks	1
			Iepakojums ar furnitūru	1
			Montāžas instrukcija, auduma paraugs	1
№ 2		D06	Roku balsts	1
№ 3		D06	Roku balsts	1
№ 4 papildu opcija, pasūtot dīvānu ar kanapē		D14	Kanapē	1
		D11	Kanapē spilvens	1
		D08	Kanapē pārvalks, pārvalka auduma paraugs	1
			Kanapē iepakojums ar furnitūru	1
			Montāžas instrukcija, auduma paraugs	1
Piegada atseviši		D20	Matracis	1
		D21	Kanapē matracis	1

### Dīvona furnitūras saraksts

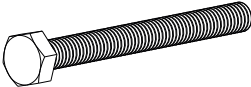
Iepakojums	Daļa	Artikuls	Nosaukums	Daudzums
Iepakojums ar furnitūru		DF02 DF15 DF16	Skrūve M6x65 Plastmasas ieliktnis Uzgrieznis M6 (paškontr.)	2
		DF11	Gremdskrūve M6x30	3
		DF31	Atspere ar āķiem	2
		DF06	Skrūve M8x45	4
		DF56	Skrūve M8x30	8
		DF42	Paplāksne M8	4

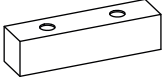

### Kanap' furnitūras saraksts

Iepakojums	Daļa	Artikuls	Nosaukums	Daudzums
Iepakojums ar furnitūru		DF30	Kanapē atspere (tikai mazajam kanapē)	2
		DF09	Skrūve M8x80	10
		DF19	Uzgrieznis M8	6
		DF42	Paplāksne M8	14
		DF74	Kanapē regulēšanas klucis	4
		DF75	Mehānisma apstāšanās	2

**Pirms montāžas darbiem:**

- 1) Pārbaudiet detaļu iepakojuma izskatu un pilnību!** Prasības par to bojājumiem tiek pieņemtas tikai par izstrādājumiem BEZ montāžas pēdām.
- 2) Saglabājiet iepakojumu un instrukciju līdz montāžas beigām!** Ja montāžas procesā tiek atklāts produkta defekts un nepilnība, Jums ir jā saglabā iesaiņojums, līdz tirdzniecības uzņēmuma pārstāvis atbrauks pie Jums.
- 3) Pārbaudiet detaļu un piederumu skaitu atbilstoši pasūtījuma komplektācijas sarakstam.** Ražotājs patur tiesības veikt izstrādājuma konstruktīvās izmaiņas, nomainīt furnitūru un stiprinājumus ar analogiem, kas nepasliktina izskatu un neietekmē produkta funkcionālās īpašības. Nepilnības vai sadalījuma gadījumā apvelciet trūkstošās daļas numuru un paziņojiet veikalam par nomaiņu.
- 4) Izpildiet šajā instrukcijā norādīto montāžas kārtību!** Montāžas un lietošanas instrukcijas neievērošana anulē ražotāja garantijas atbildību.
- 5) Lai uzstādītu divāngultu, izvēlieties līdzenu grīdas virsmu!** Pie grīdas izliekumiem un augstiem paklājiem ir iespējamas novirzes divāngultas pārveidošanas mehānisma darbībā, izstrādājuma formas deformācijas.
- 6) Veiciet divāngultas montāžas darbus divatā.** Pārvietojiet visas detaļas uzmanīgi, bez raustīšanās, novietojiet tās droši, izvairieties no viņu krišanas un triecieniem!
- 7) Pārvietojiet mēbeles un to daļas, tikai nedaudz paceļot.** Tas novērsīs deformācijas un lūzumus.
- 8) Montāžas laikā noteikti ieeļļojiet pacēlāja mehānismu saskaņā ar instrukcijām!** Tas ļaus izvairīties no priekšlaicīgas čīkstēšanas. Atkārtoti ieeļļojiet, pievelciet izteikti vaļīgas skrūves un uzgriežņus vismaz reizi sešos mēnešos.

**Montāžas darbiem nepieciešams:**

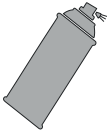
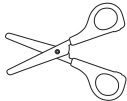
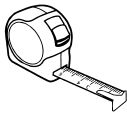
	Skrūvgriezis krusta
	Atvērta uzgriežņu atslēga №13 x 1 Atvērta uzgriežņu atslēga №10 x 2
	Papīra dvielis
	Silikona izsmidzināmā smērviela
	Šķēres
	Mērlente

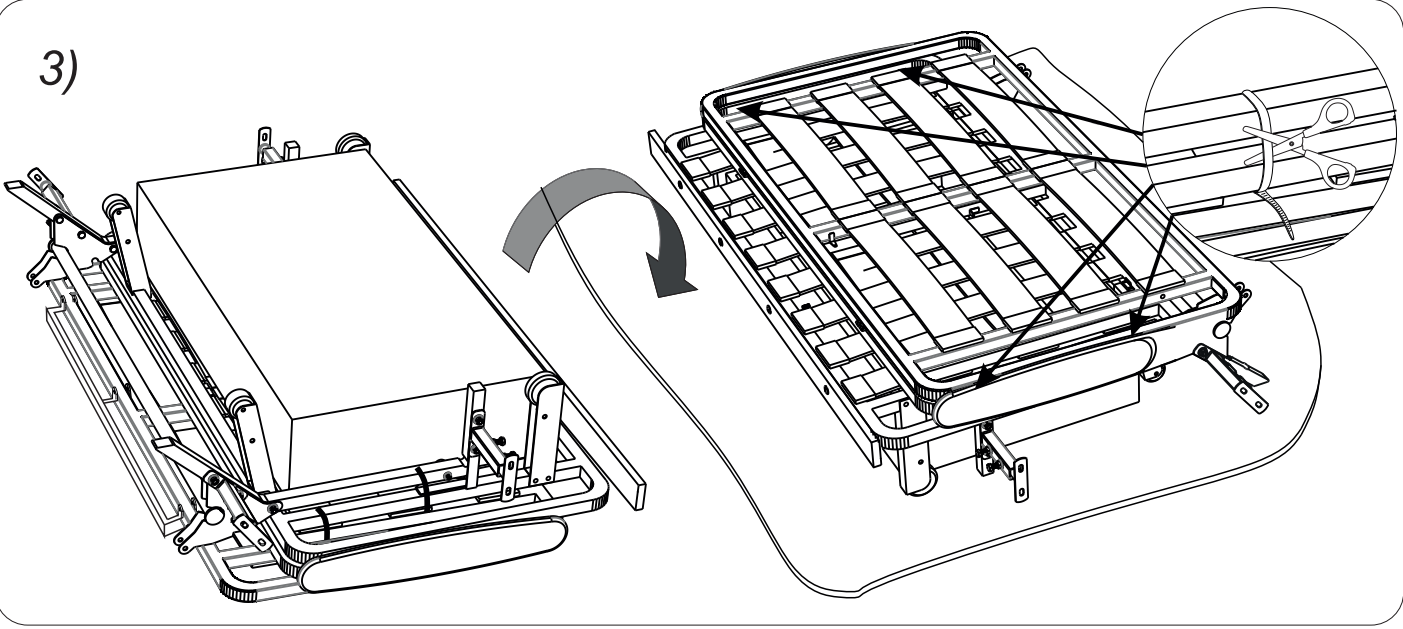
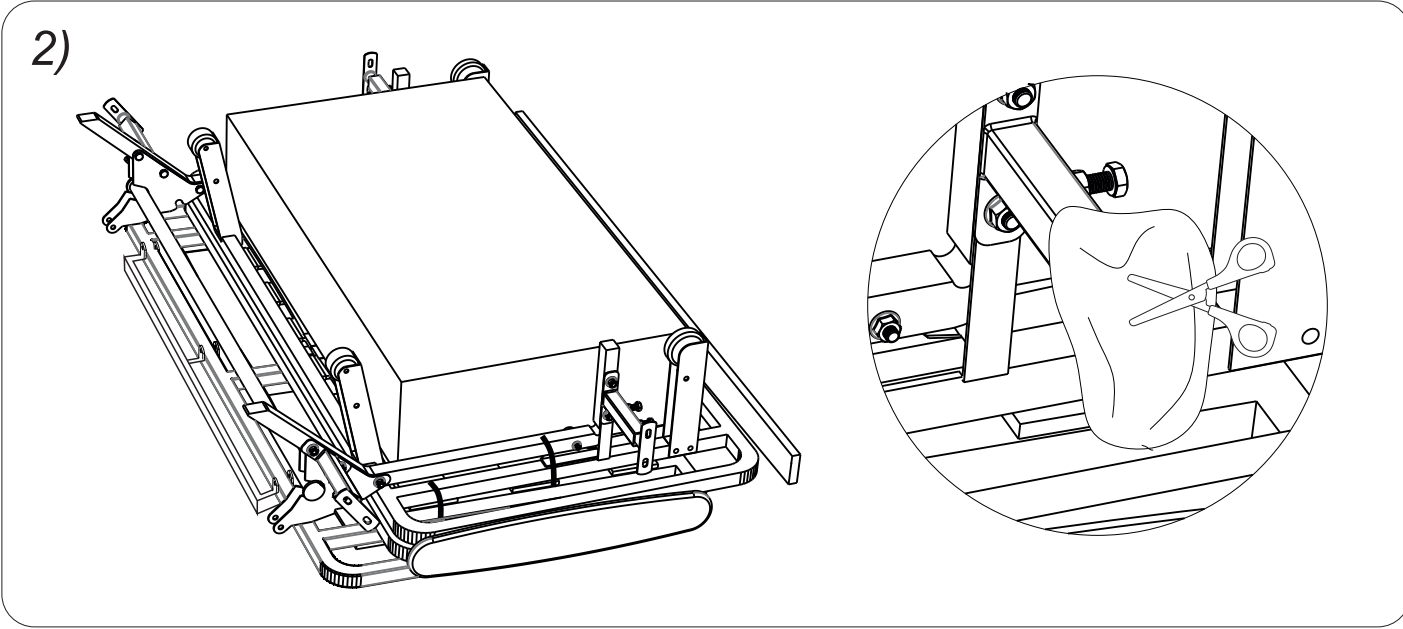
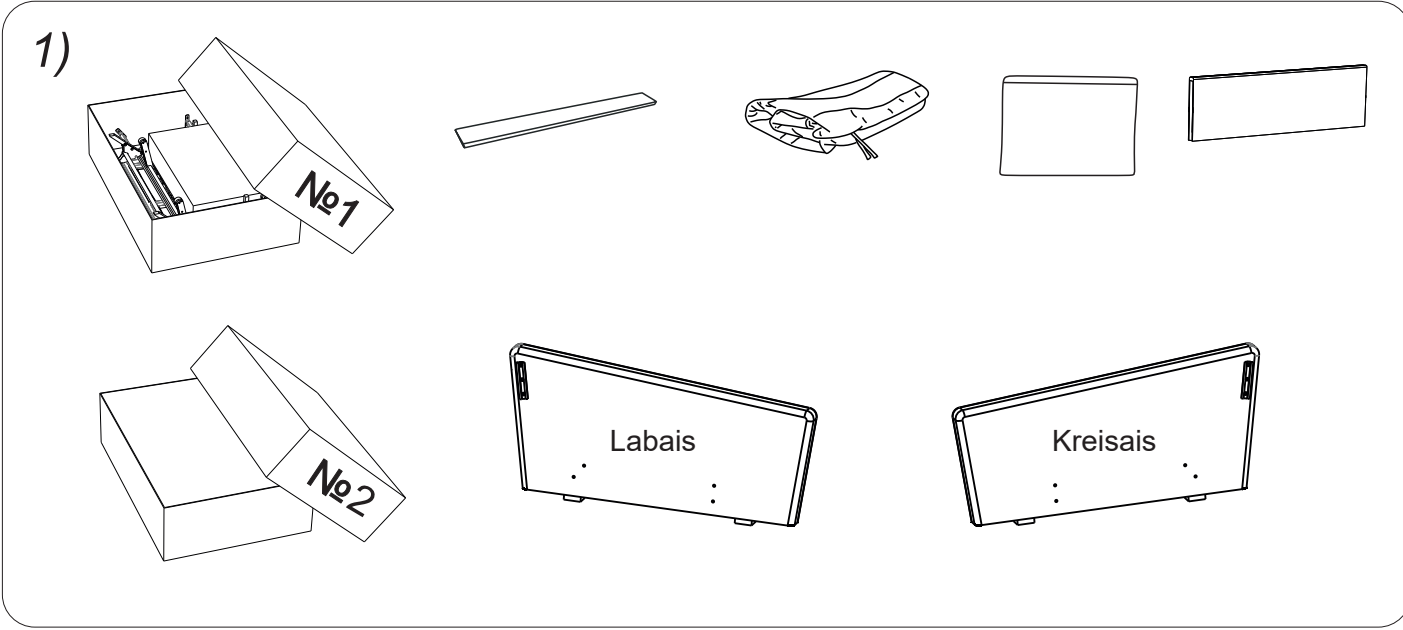

4)

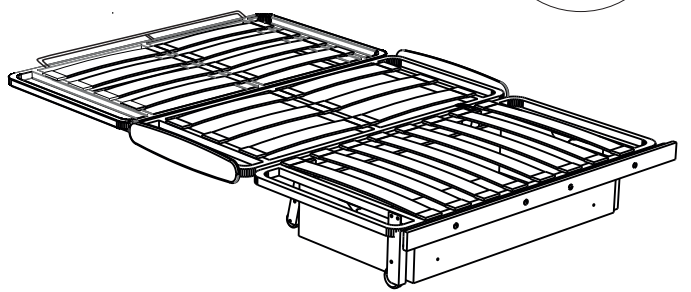
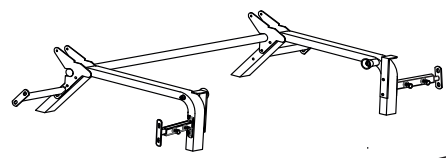
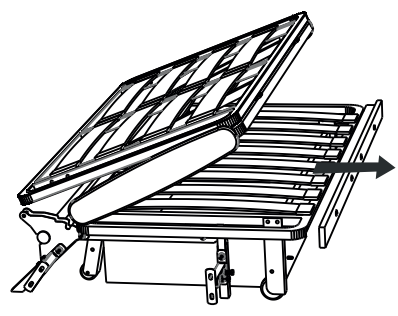

rāmi noņemt no pamatnes

5)

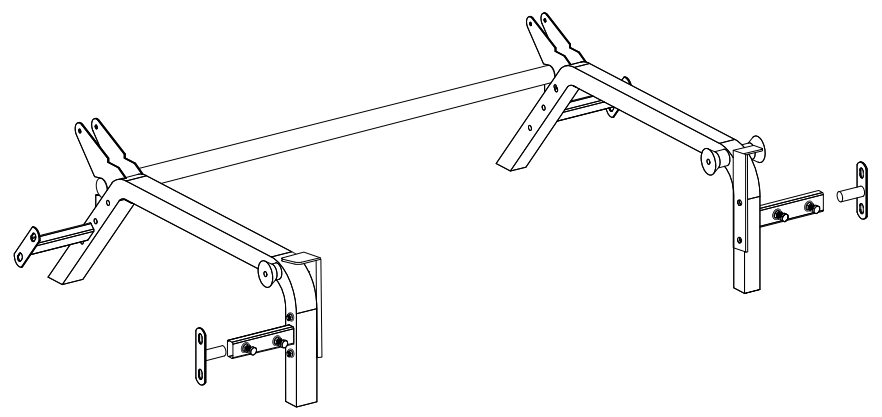
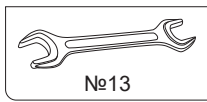
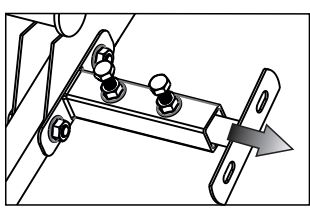
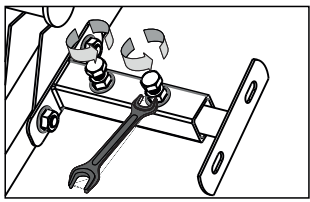

6)

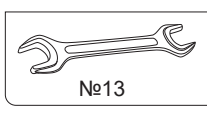
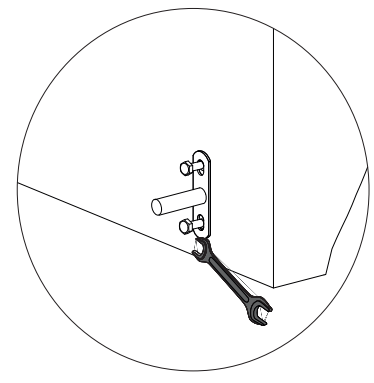
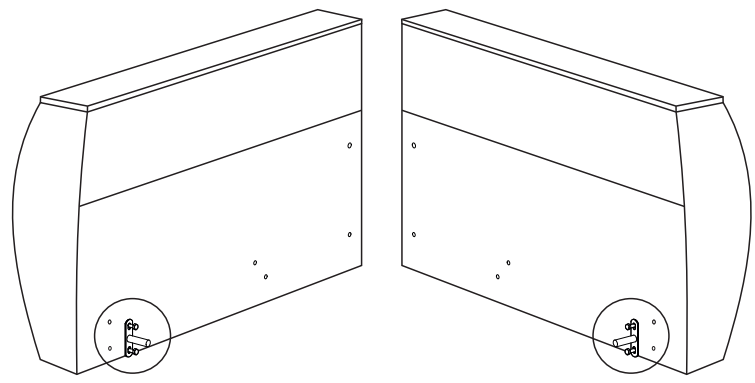

Montējot stūra dīvānu, uzstādīt kronšteinu vienā roku balstā (no tās puses, kas ir pretēja kanapē)

7)

Nepievelciet stingri

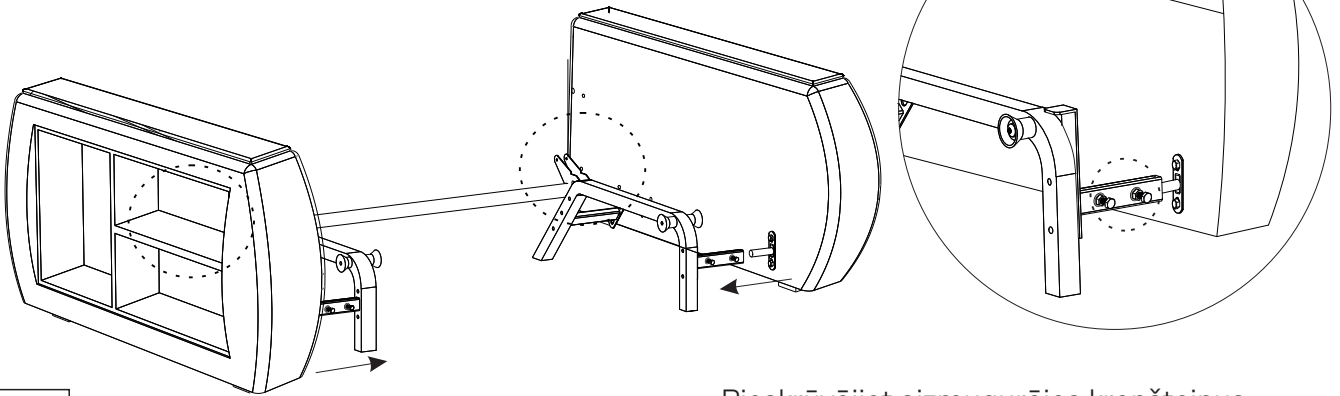

Pieskrūvējiet aizmugurējos kronšteinus.  
Priekšējo kronšteinu skrūves nav  
pievilktas.

8)

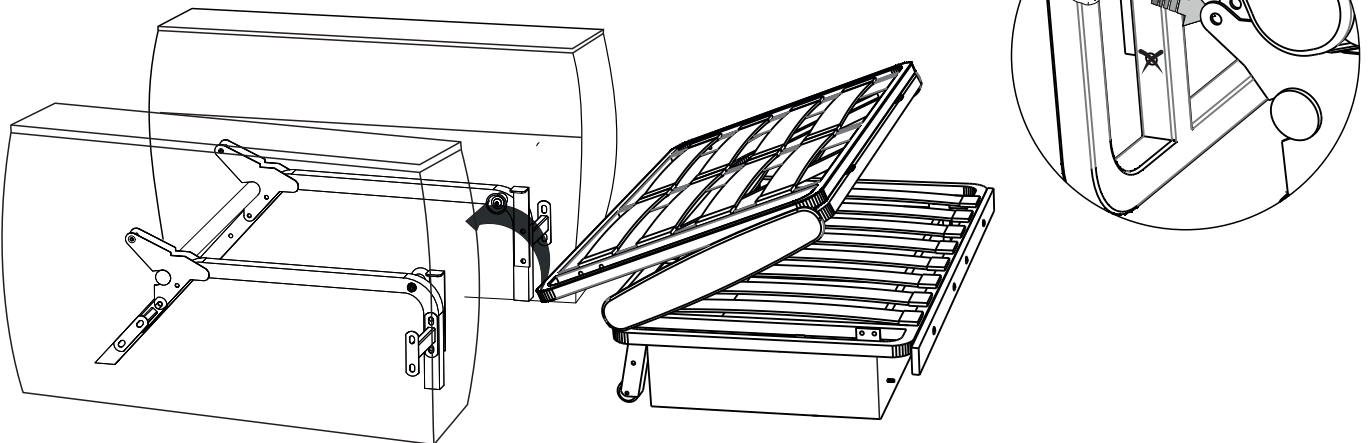

9)

Nepievelciet stingri

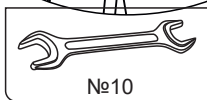
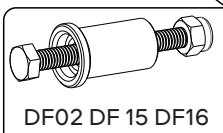
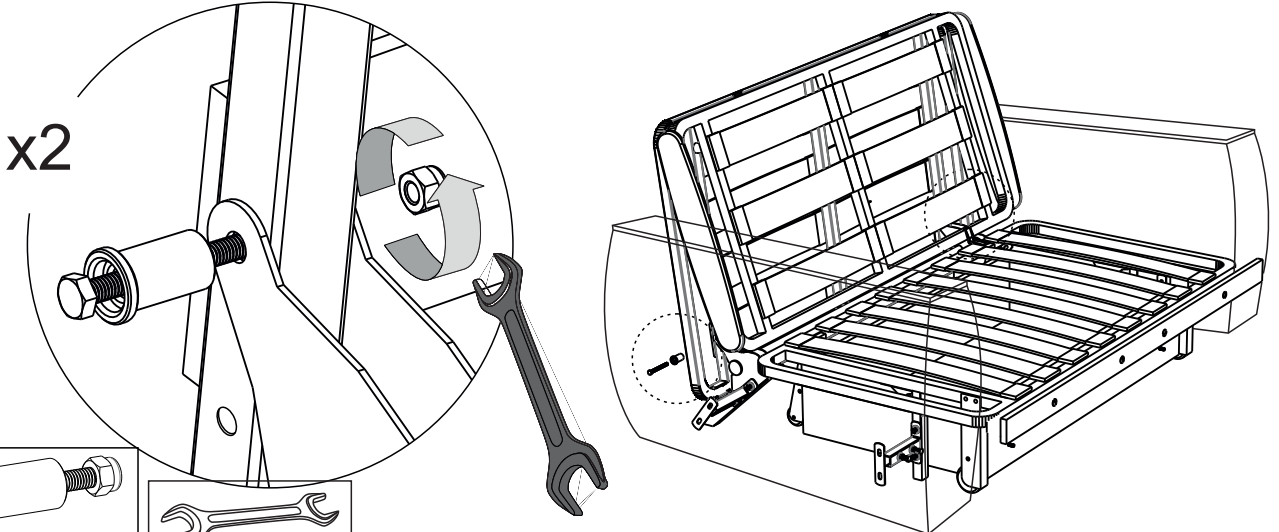



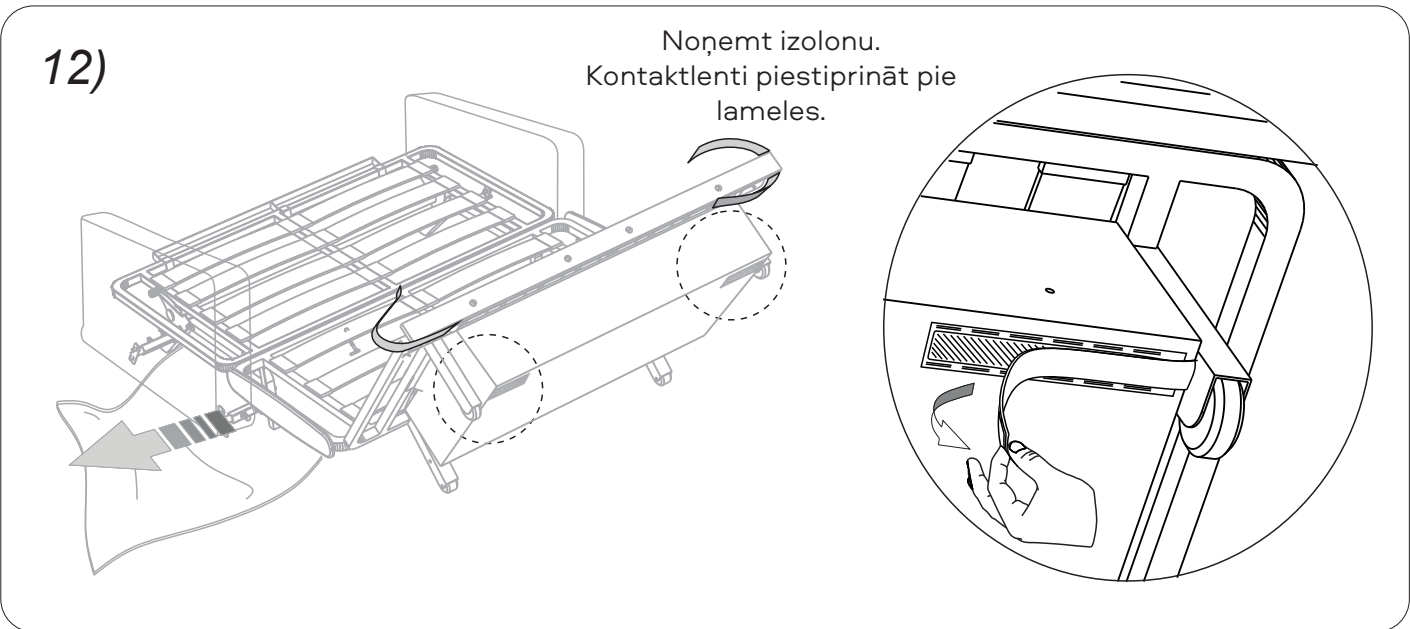
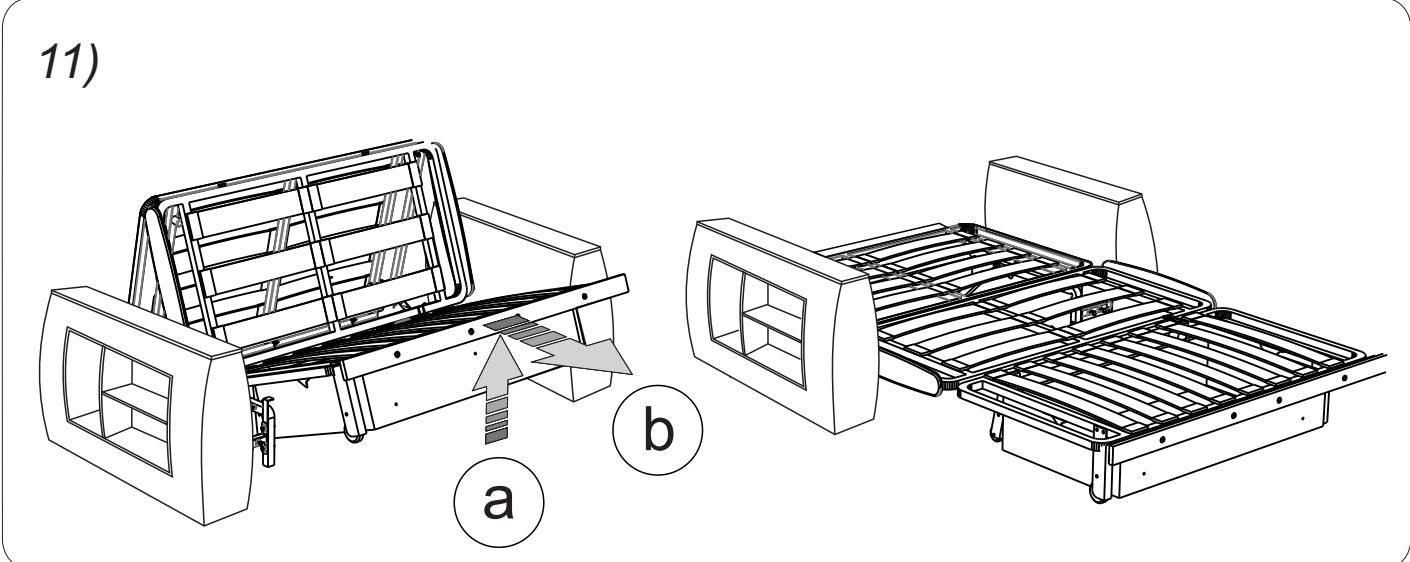
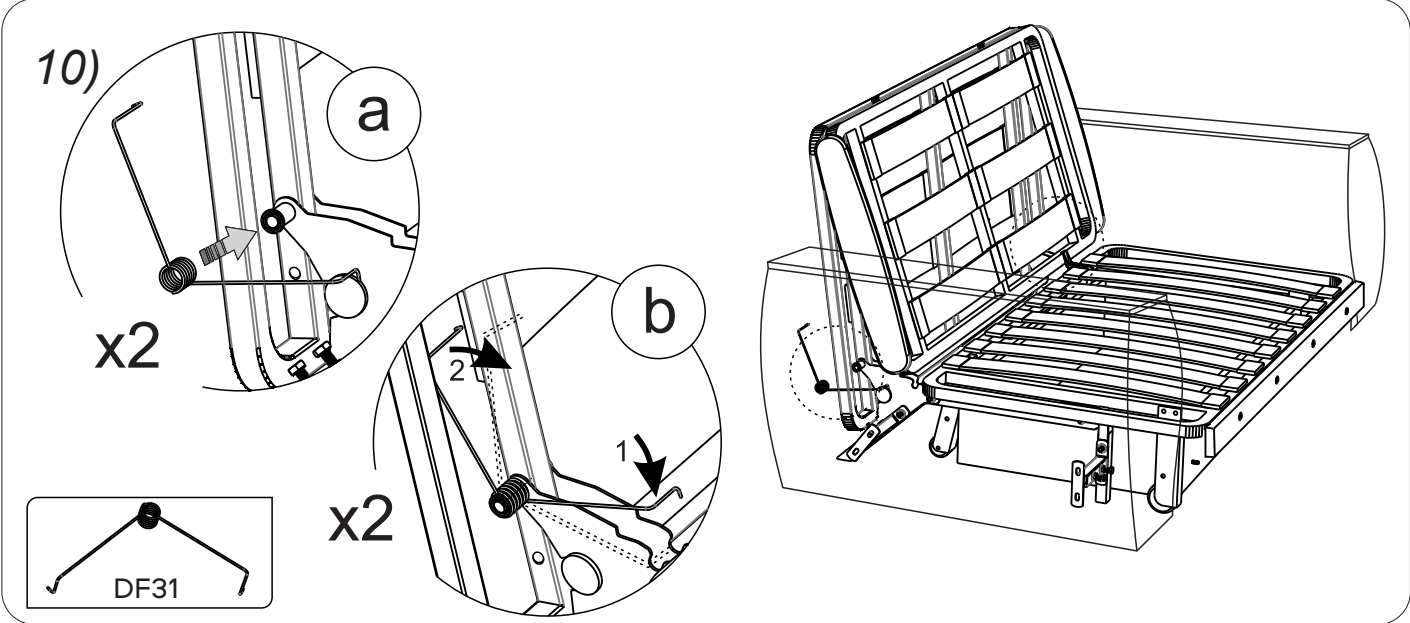

13)

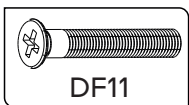
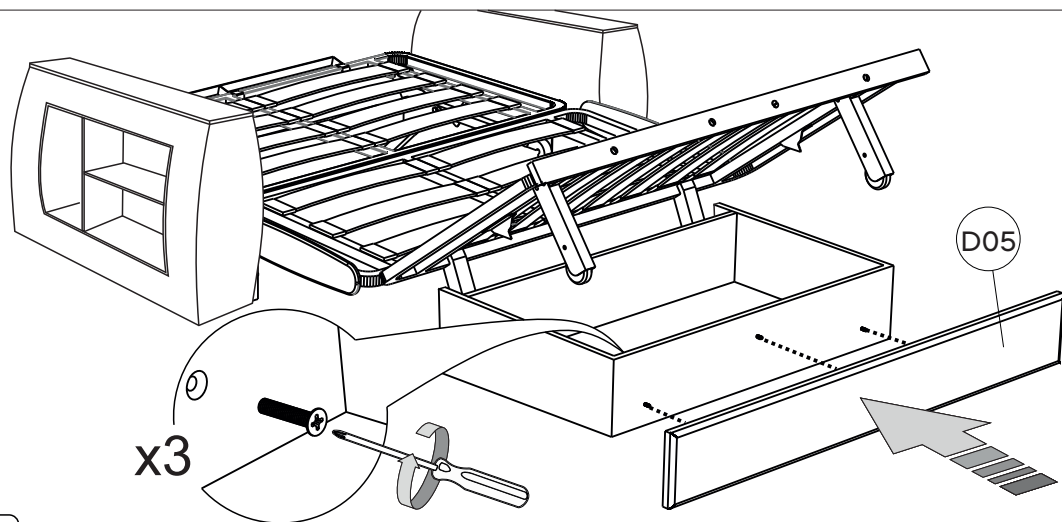

Karaļa dibenu nosaka sēru joslas klātbūtne.

14)

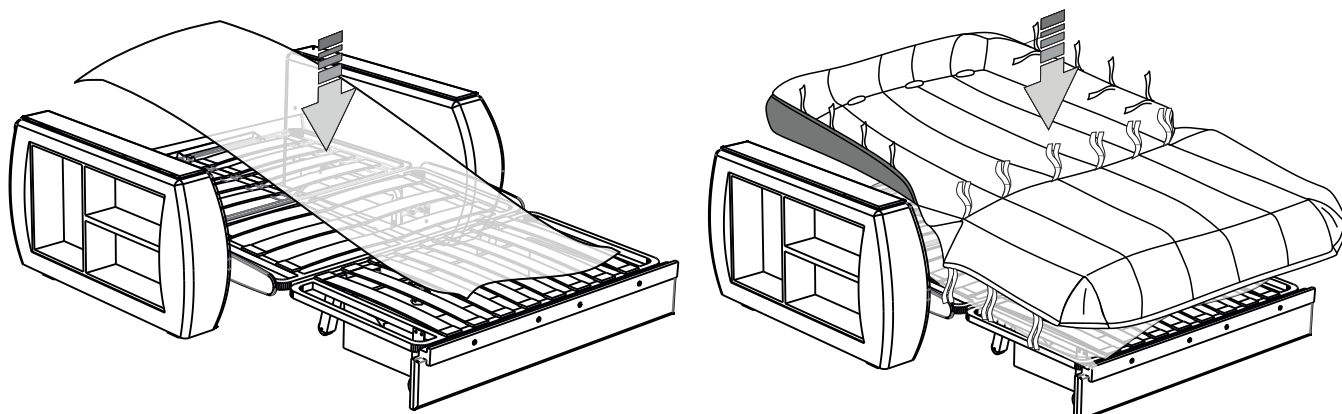

Plēvi no dīvāna iesaiņojuma uzklāt uz mehānisma pārvalka aizsardzībai no smērvielas

15)

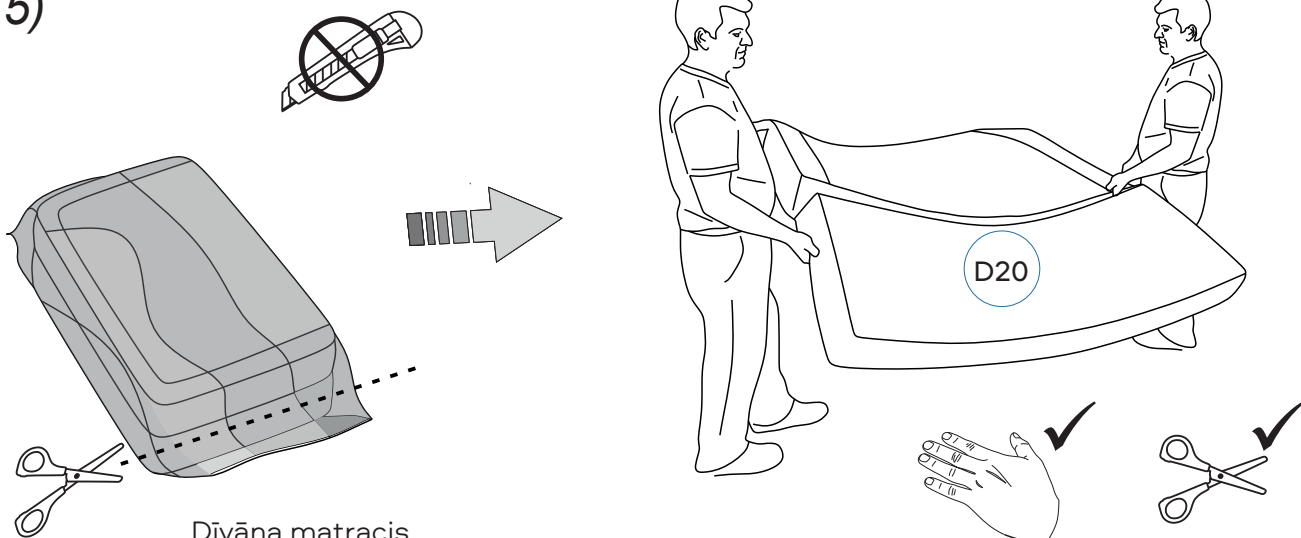

Dīvāna matracis

16)

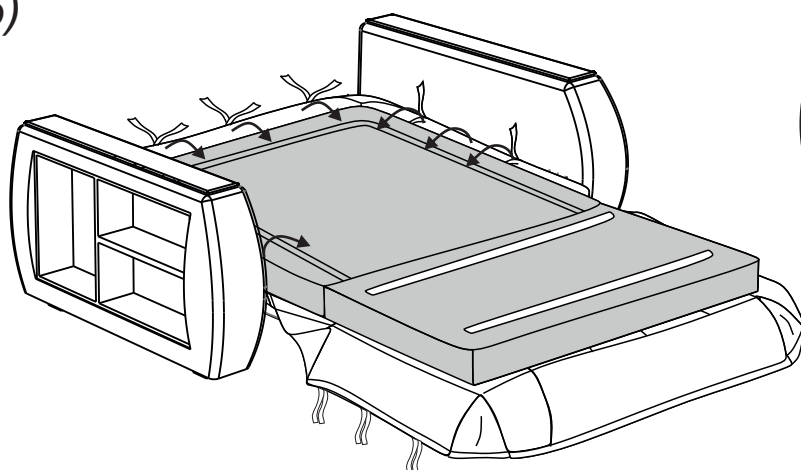

Izlīdziniet matrača un pārvalka vīles un stūrus.  
Galvgaļa galā kontaktlentes izvilkot caur atverēm pārvalkā.

17)

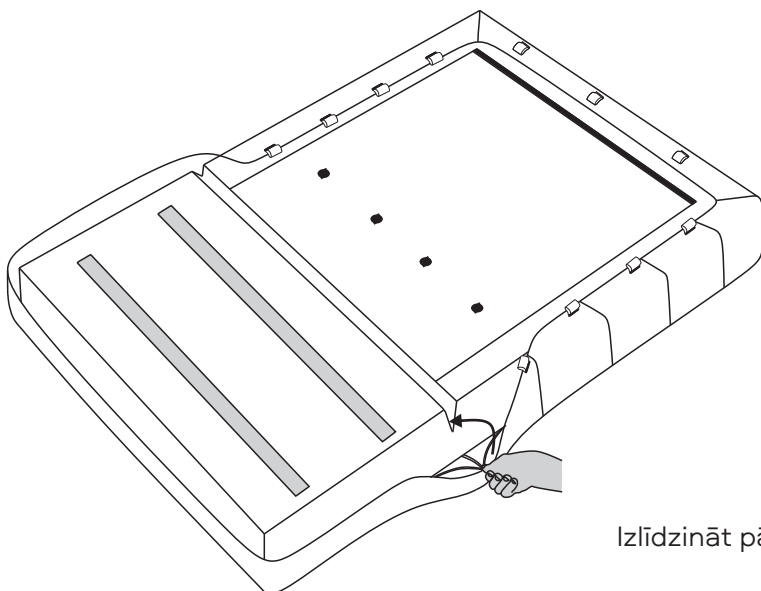

Izlīdzināt pārvalka un matrača vīles.

18)

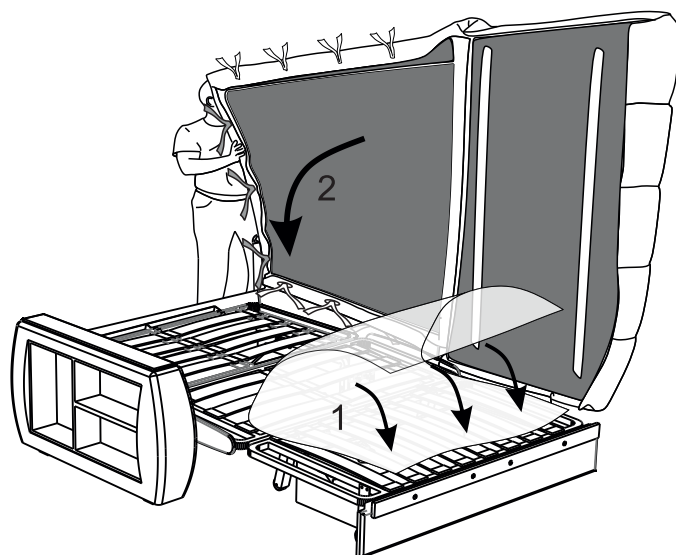

19)

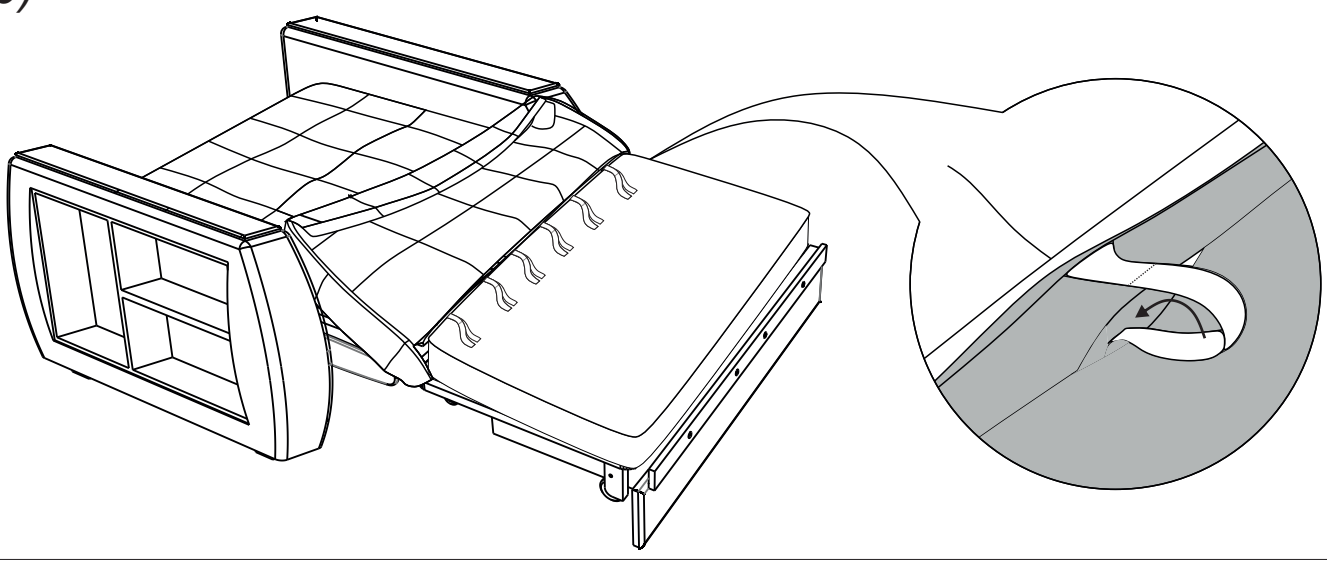

20)

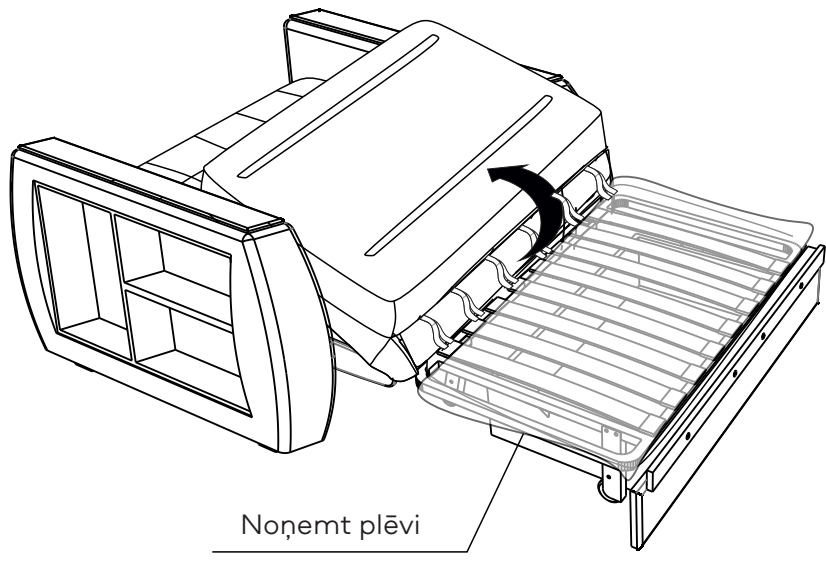

Noņemt plēvi

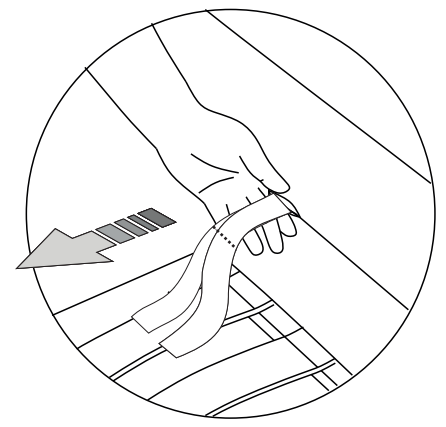

21)

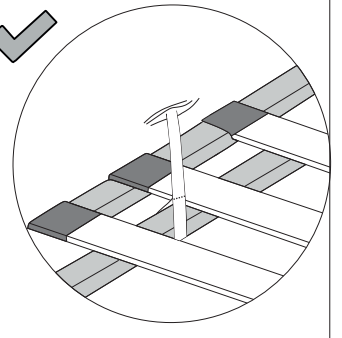
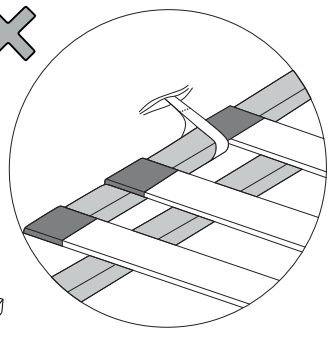
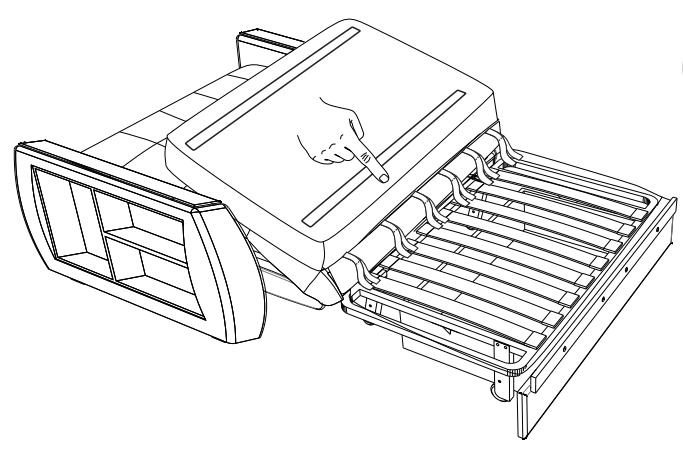

Kontaktlentes nostiprināt,  
stingri pievelkot līdz  
šuves līnijai

22)

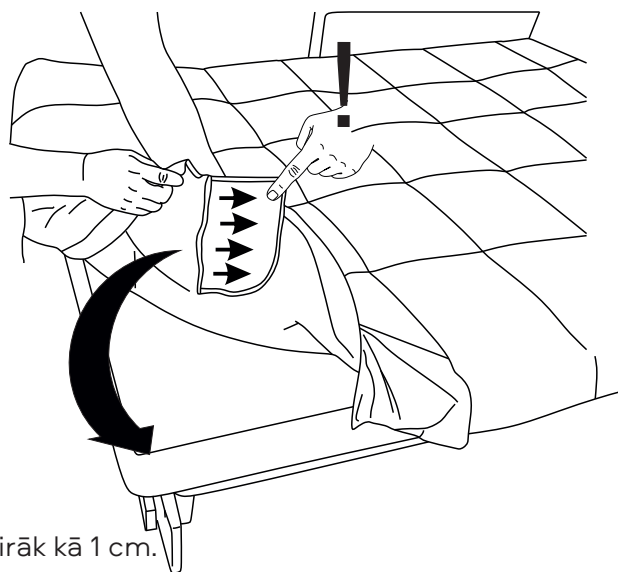
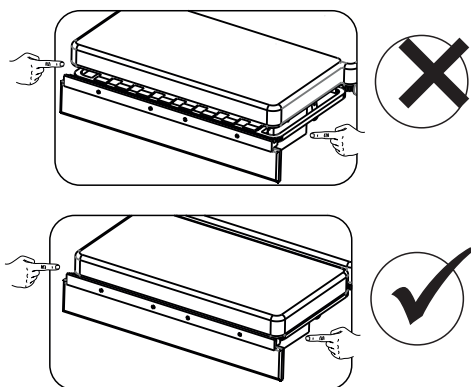

Matracim vajadzētu izvirzīties ārpus Līstes malas ne vairāk kā 1 cm.

23)

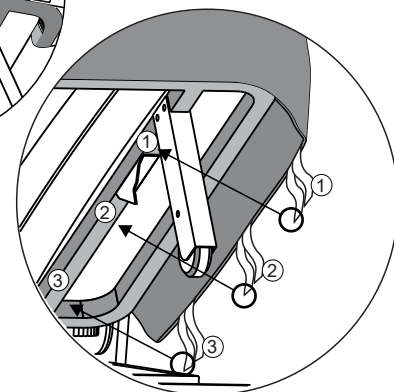
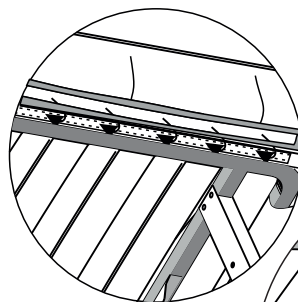
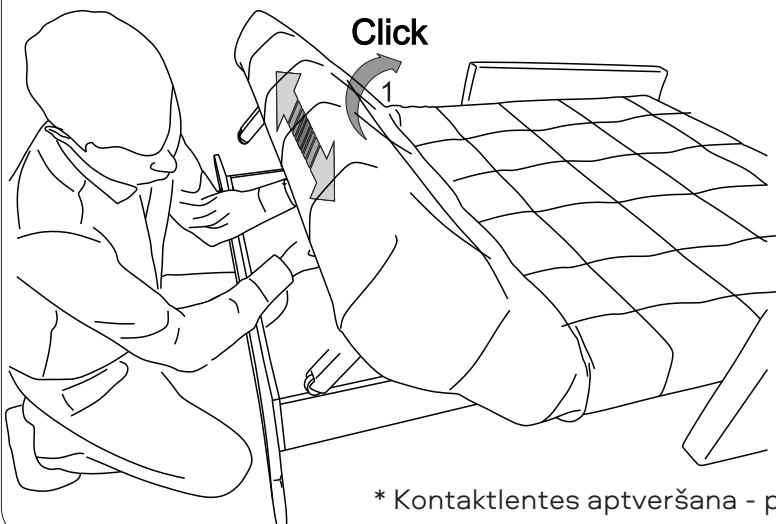

\* Kontaktlentes aptveršana - pilns aplis

24)

Savākt lieko pārvalka daļu matrača locījuma vietā, lai atvieglotu transformāciju

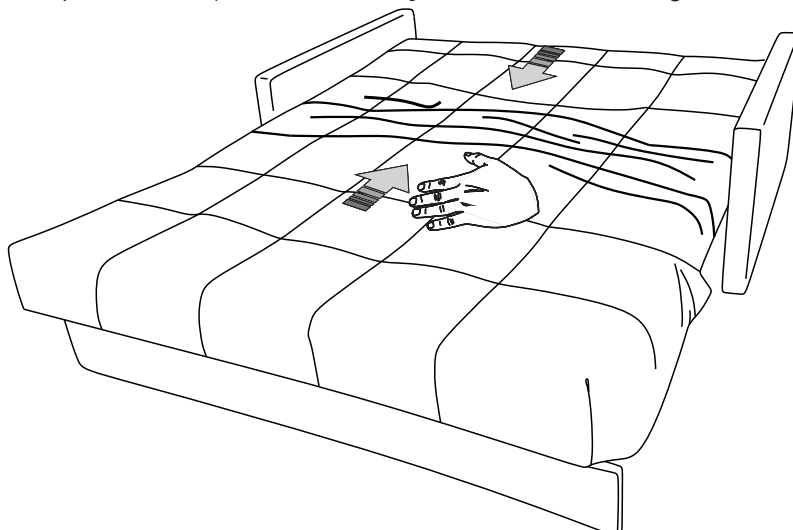

25)

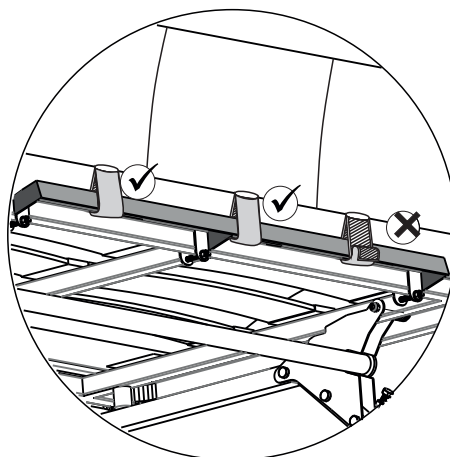
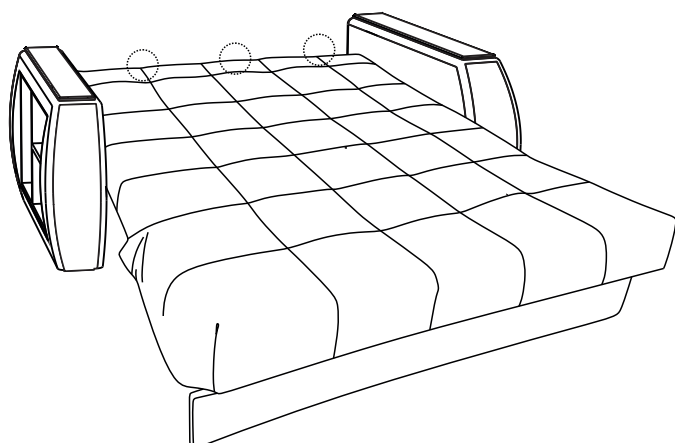

26)

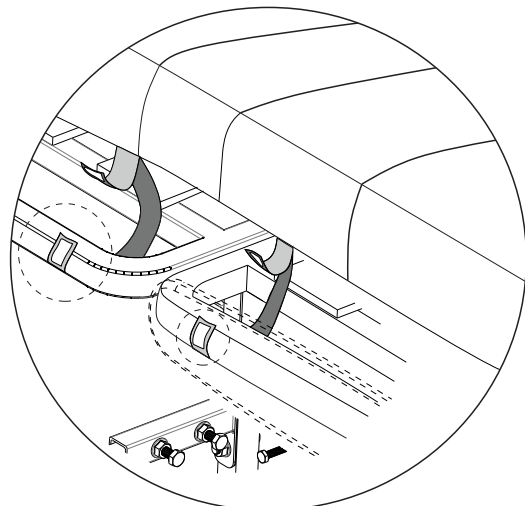
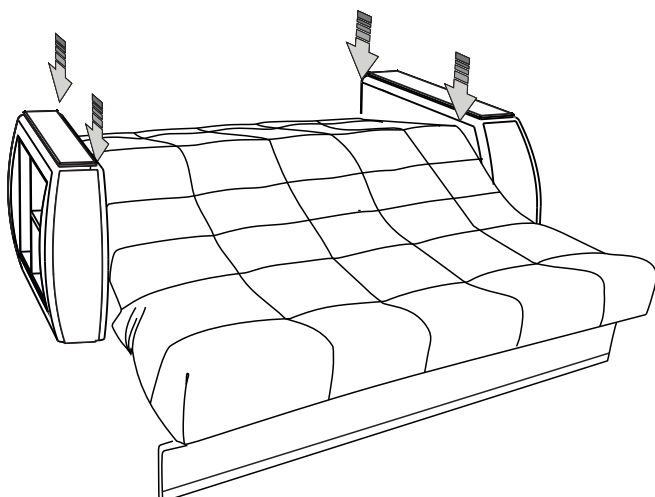

Pārvietojiet dīvānu daļēji atlocītā stāvoklī  
Fiksējot kontaktlentes, tām jābūt maksimāli pievilktām.

27)

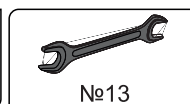
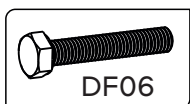
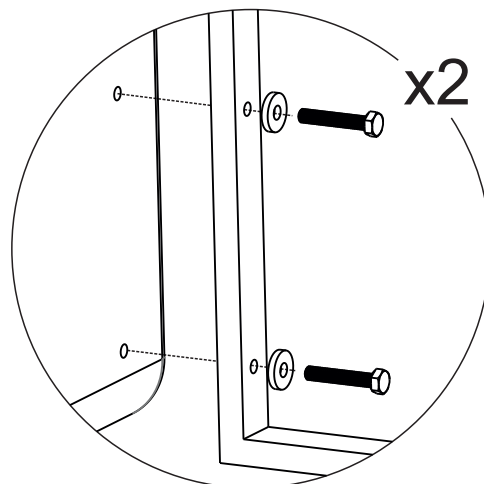
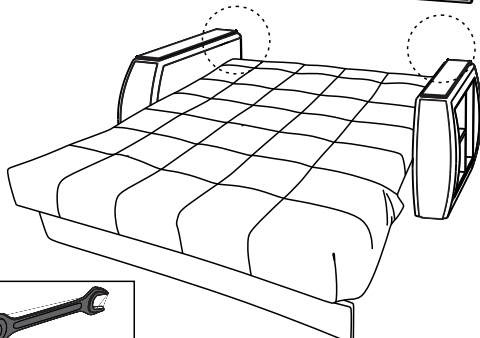
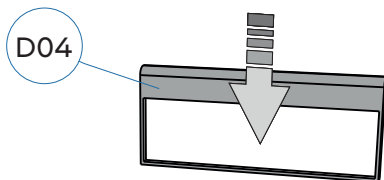



Ja ir kanapē, pāriet pie stūra dīvāna montāžas

28)

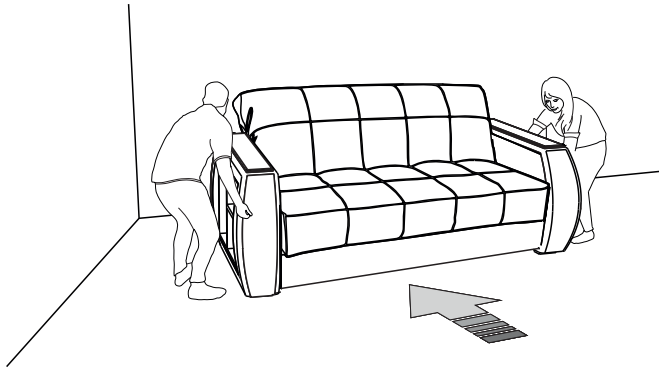

$A \approx B$  <sup>OK</sup> 

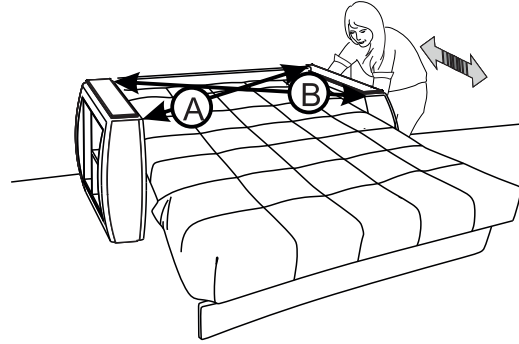

Uzstādiet dīvānu pastāvīgas darbības vietā

29)

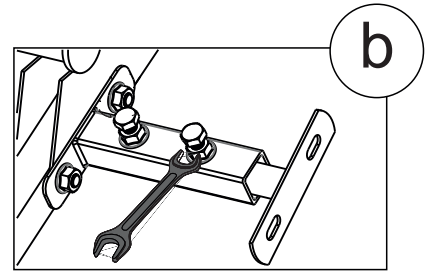
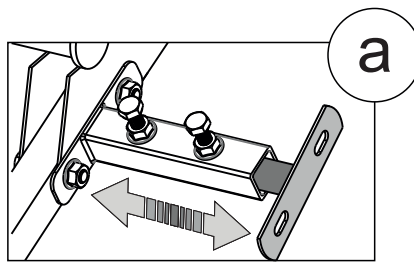
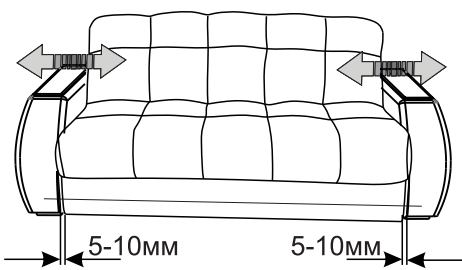

Pievilkt

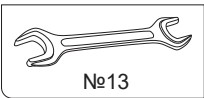

30)

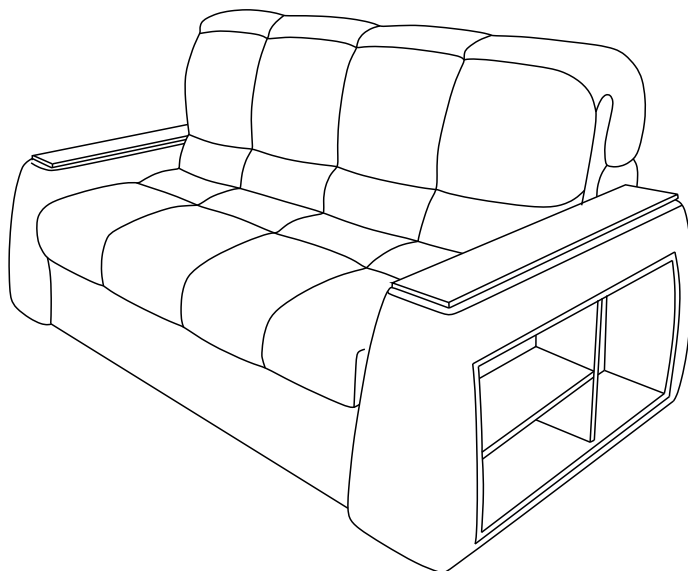



Stūra dīvāna montāža

31)

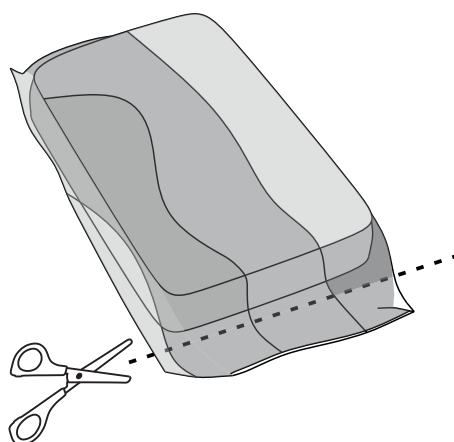
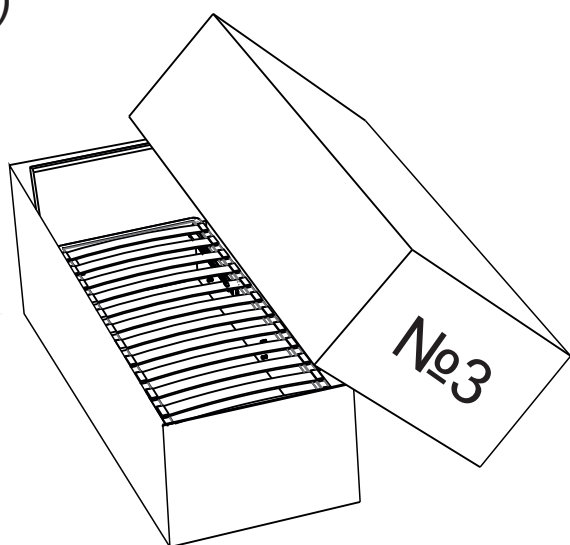

32

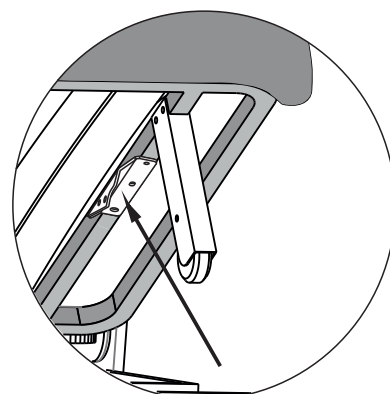
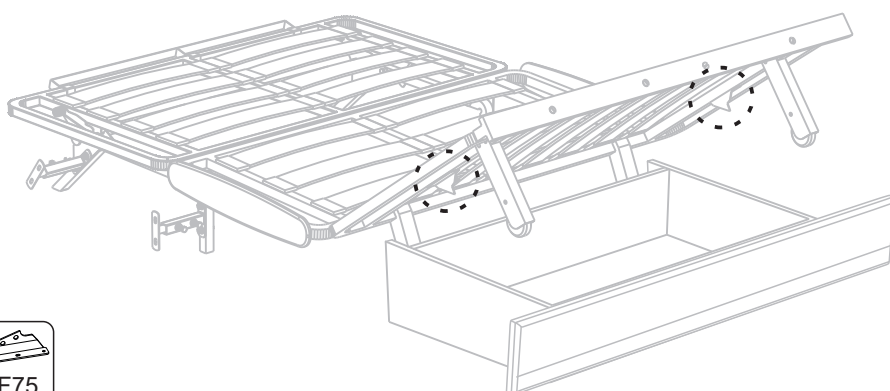

33)

Atsperes montē tikai mazā kanapē

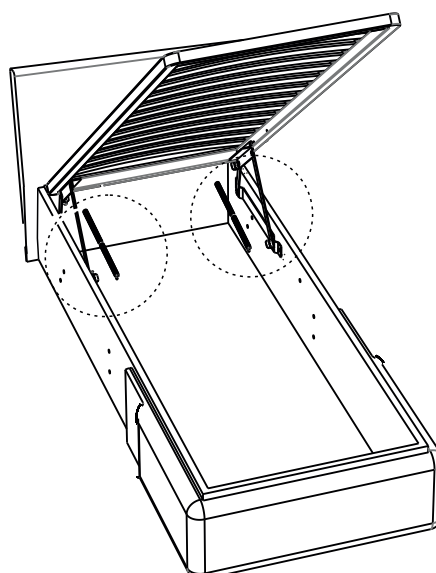
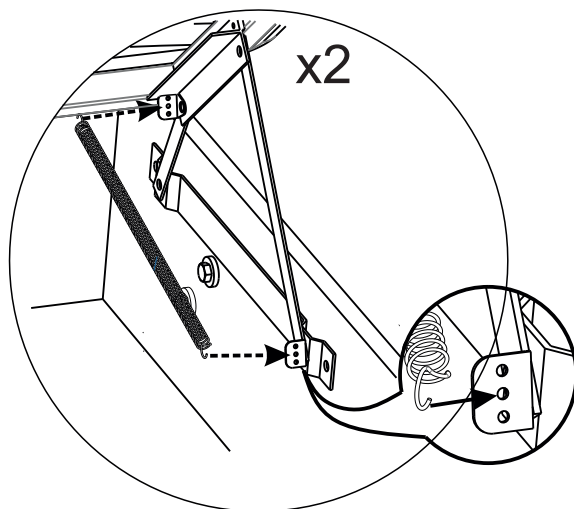

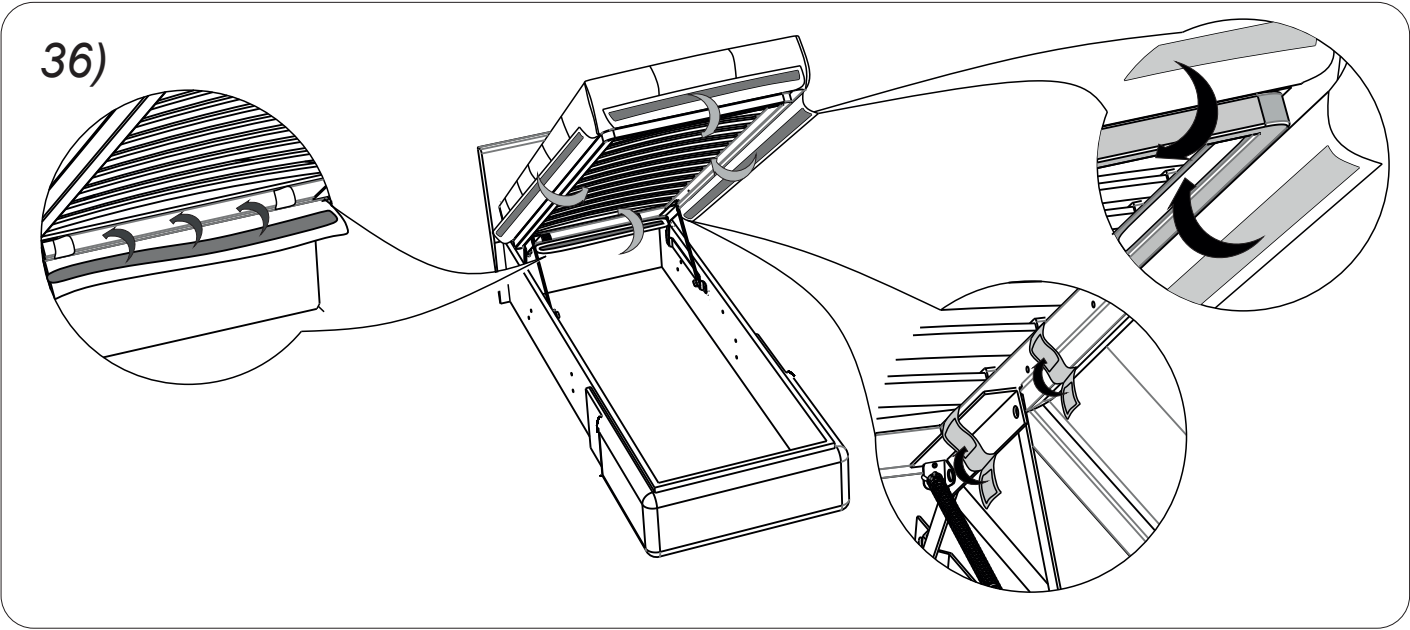
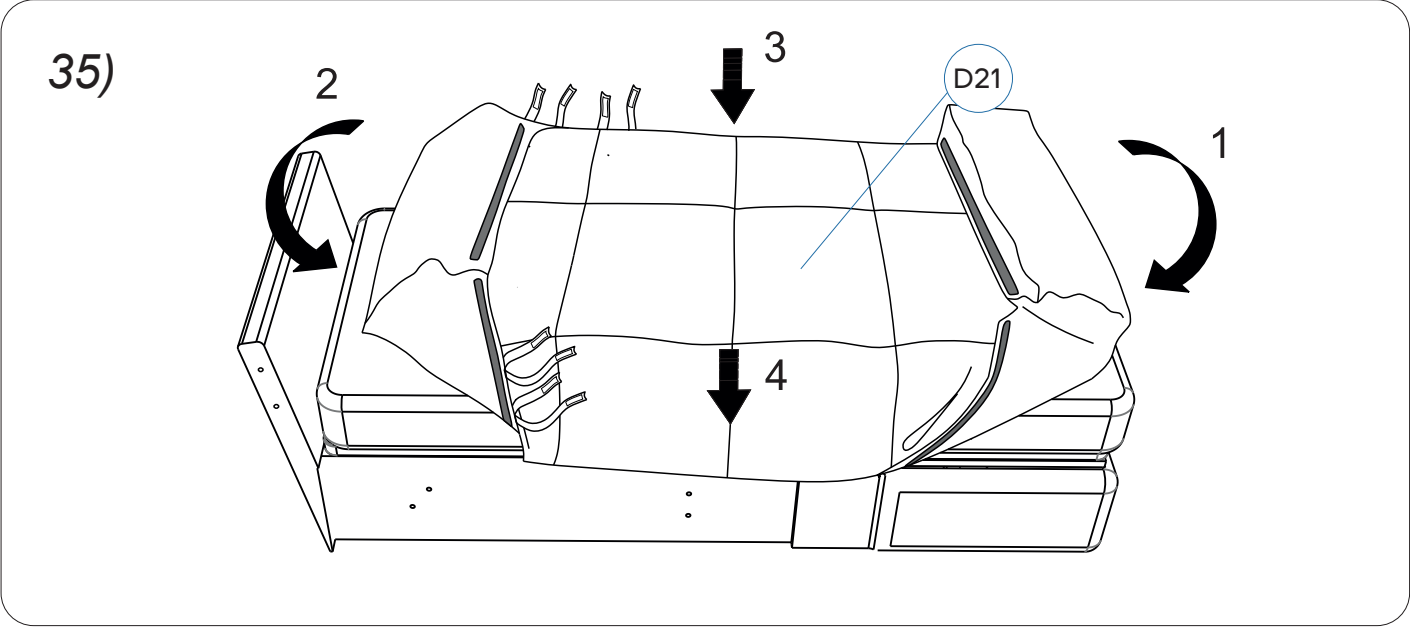
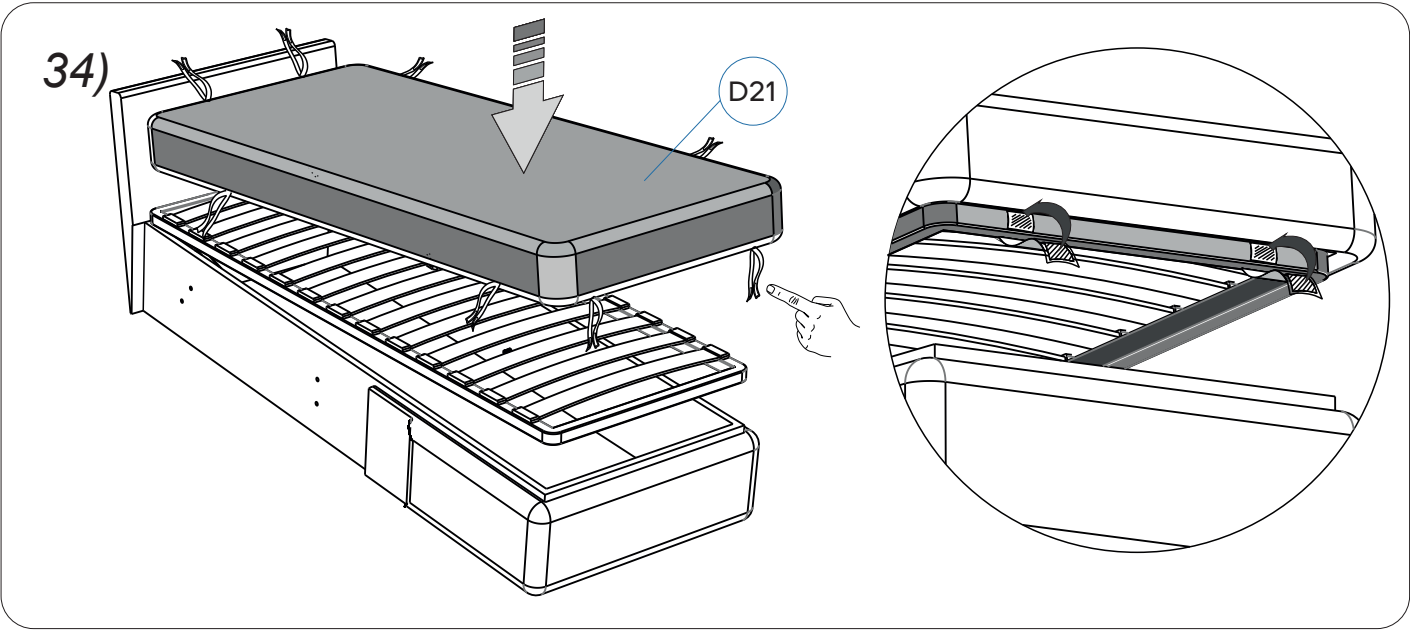

37)

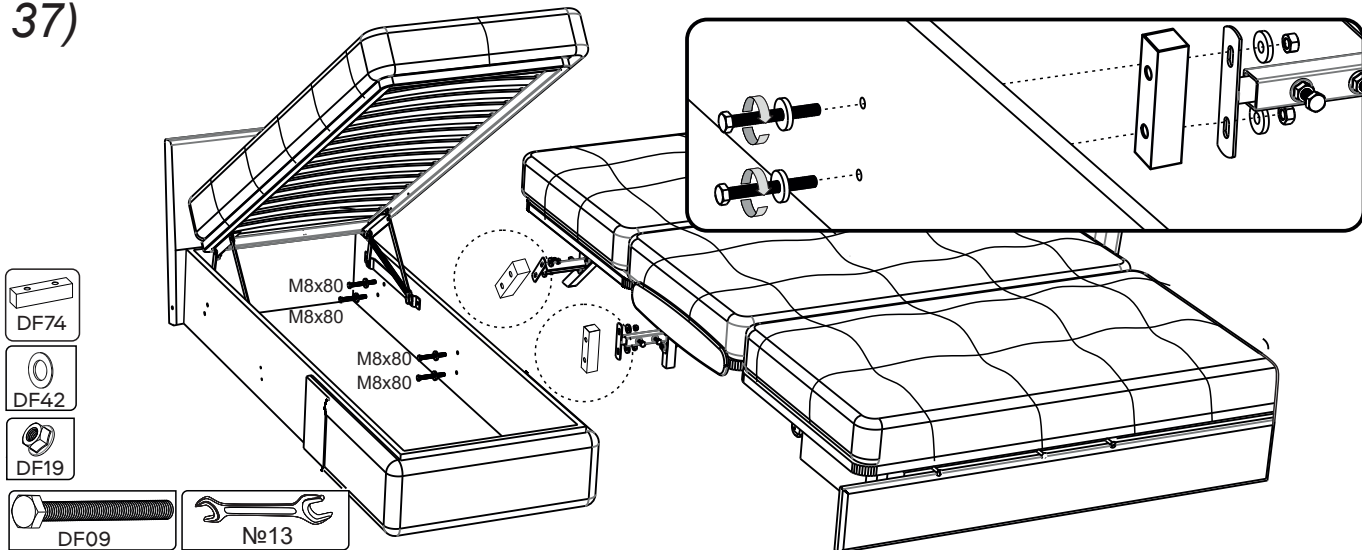

38)

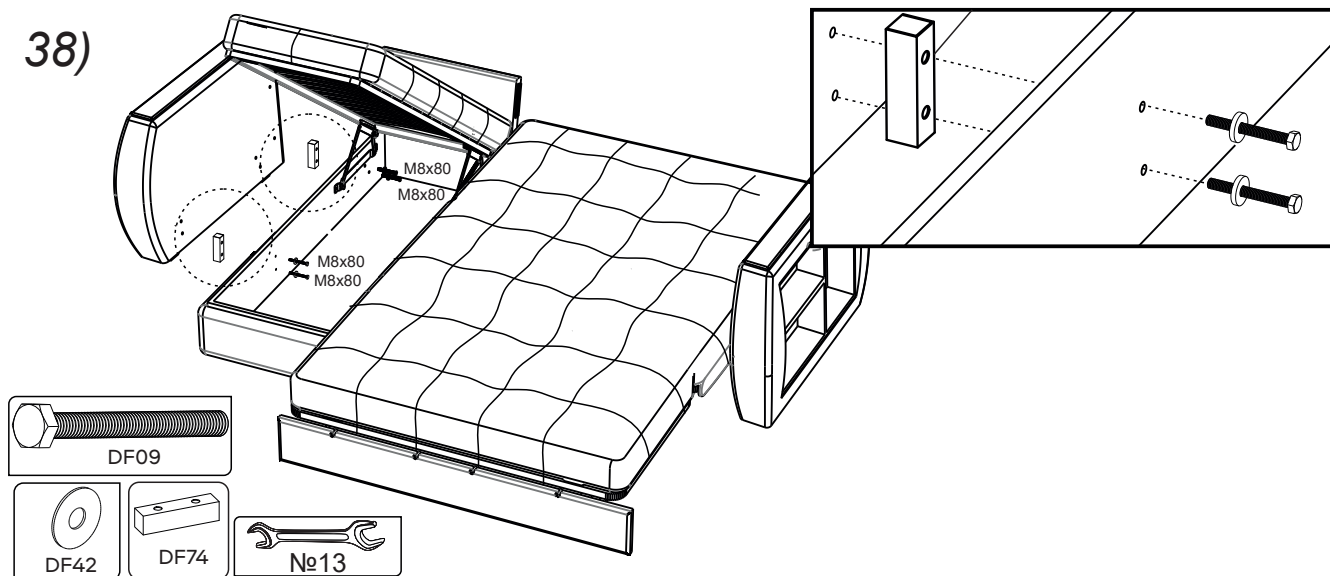

39)

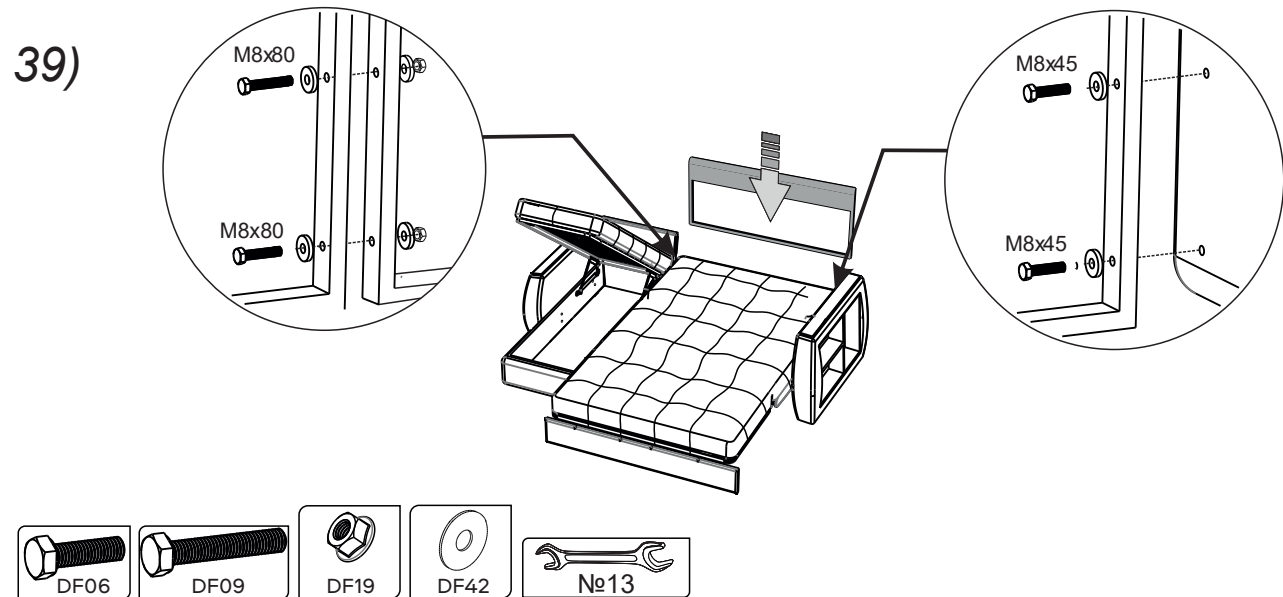

40)

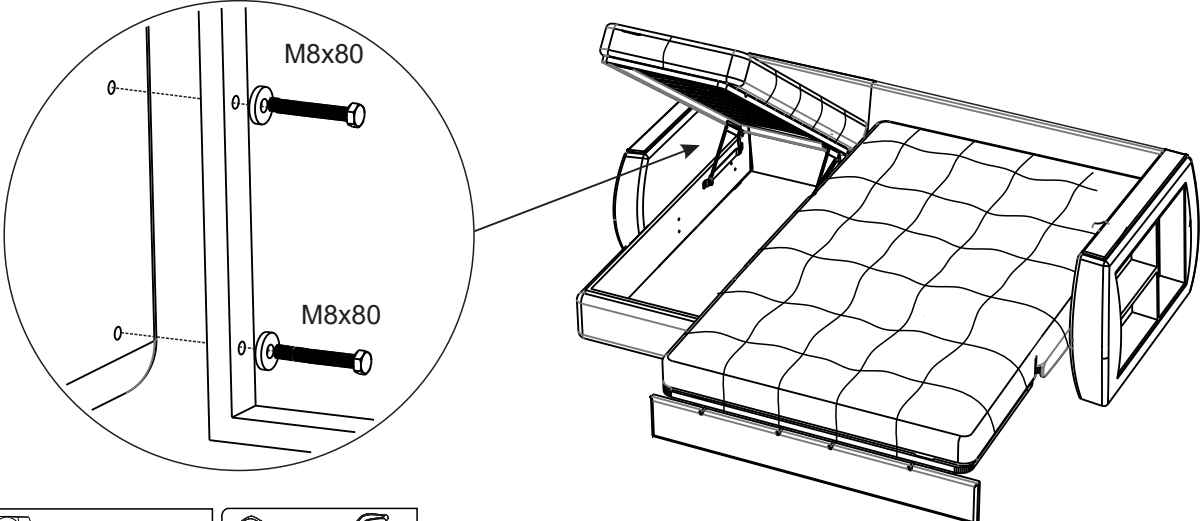

M8x80

M8x80

DF42

DF09

№13

41)

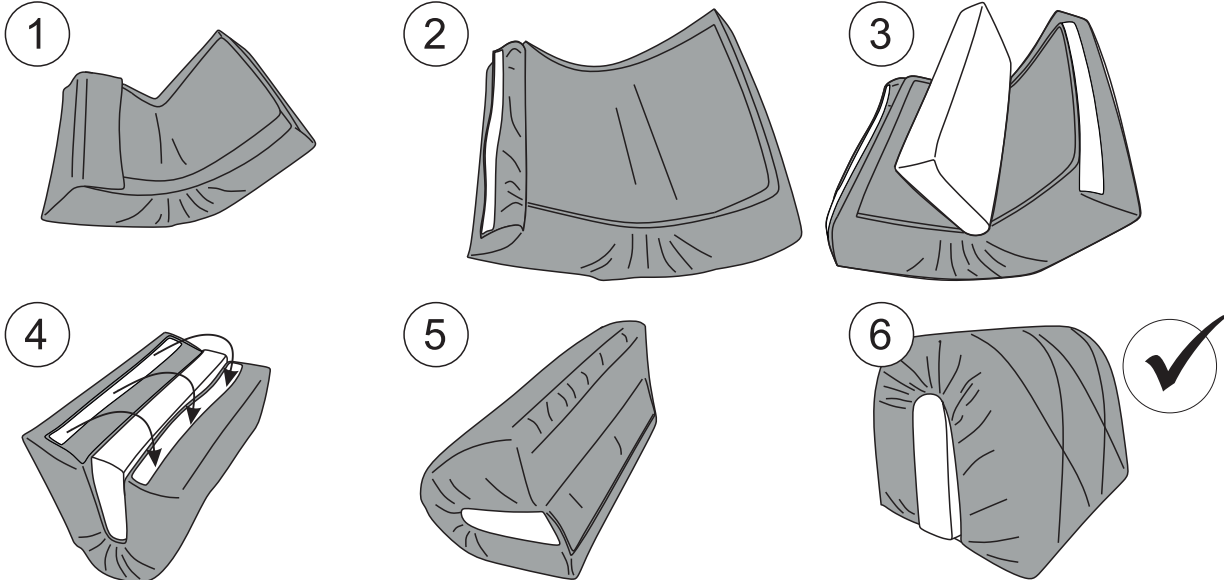

1

2

3

4

5

6

42)

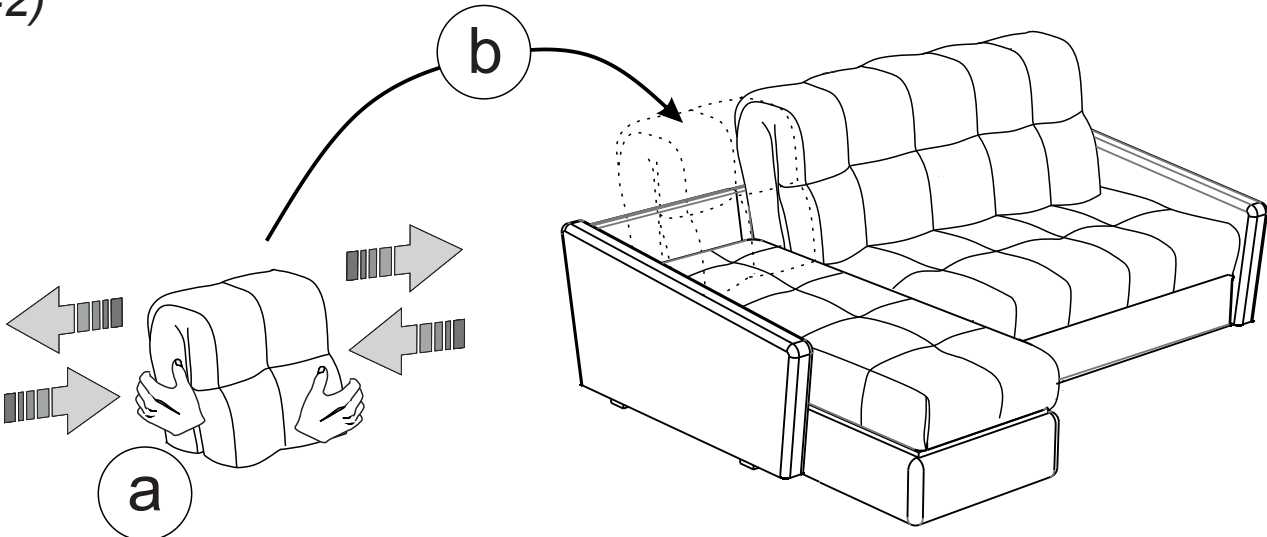

a

b

43)

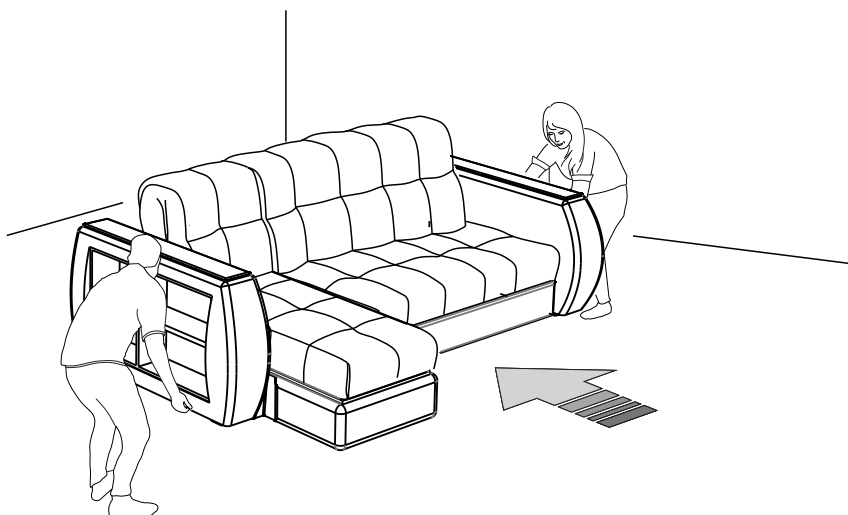

Uzstādiet dīvānu pastāvīgas darbības vietā

44)

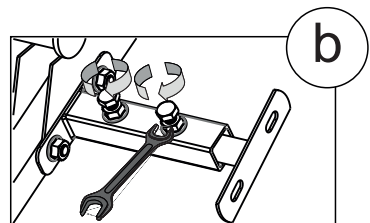
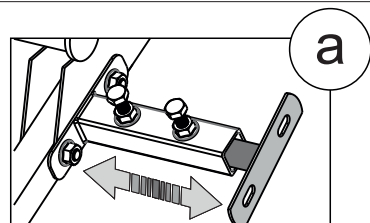
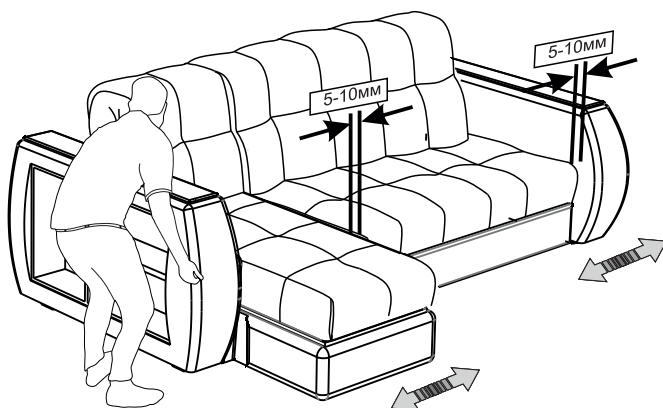

Pievilkt



45)

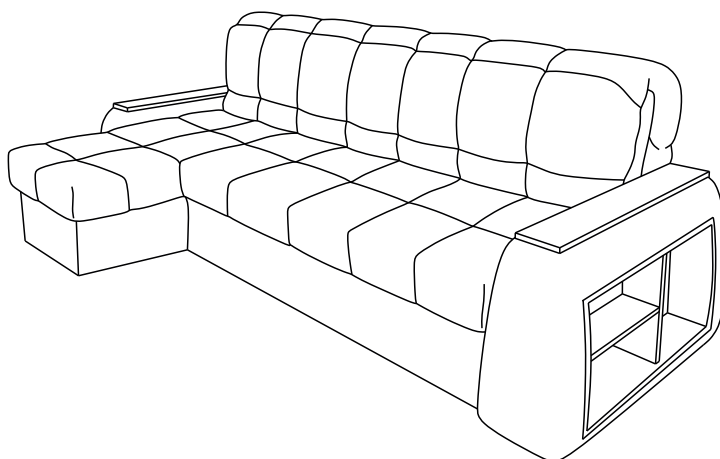

Dīvāna transformācijas kārtība

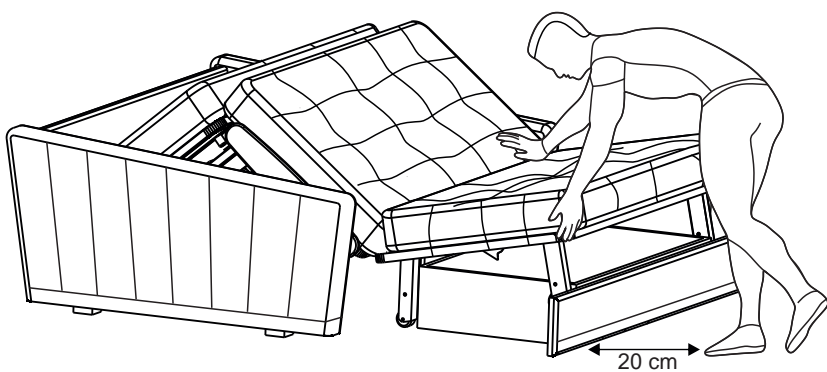
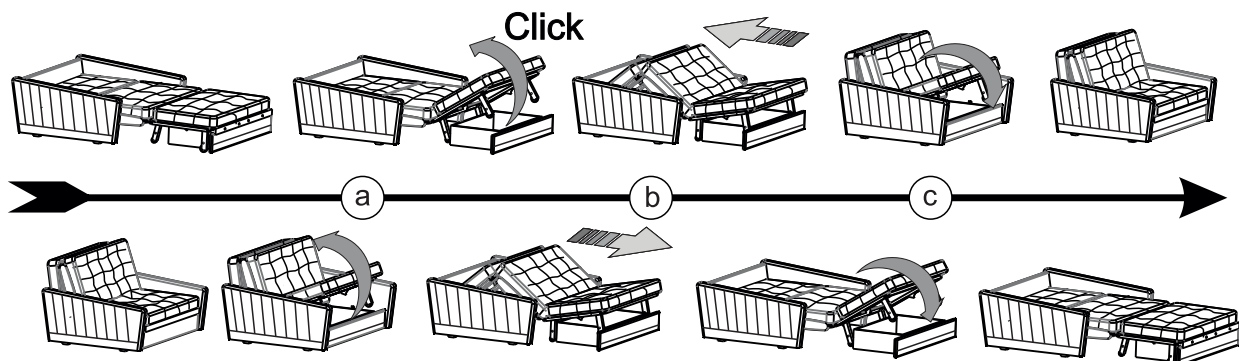

Ja dīvāna sēdekli nevar pacelt, atvienojiet transportēšanas lipenes.

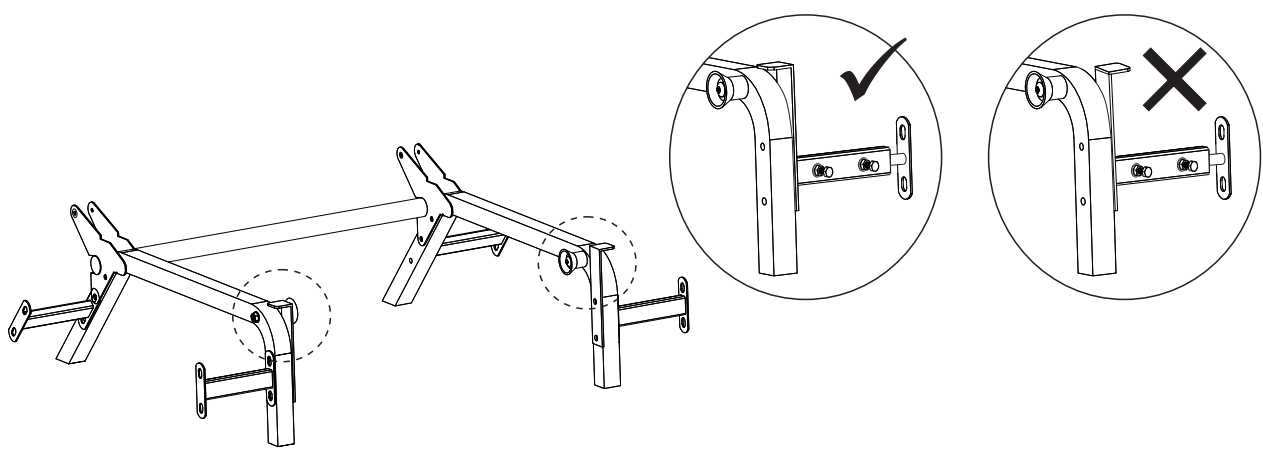

Ja dīvāna sēdekli nevar aizbīdīt, pārbaudiet mehānisma balstu pozīciju.



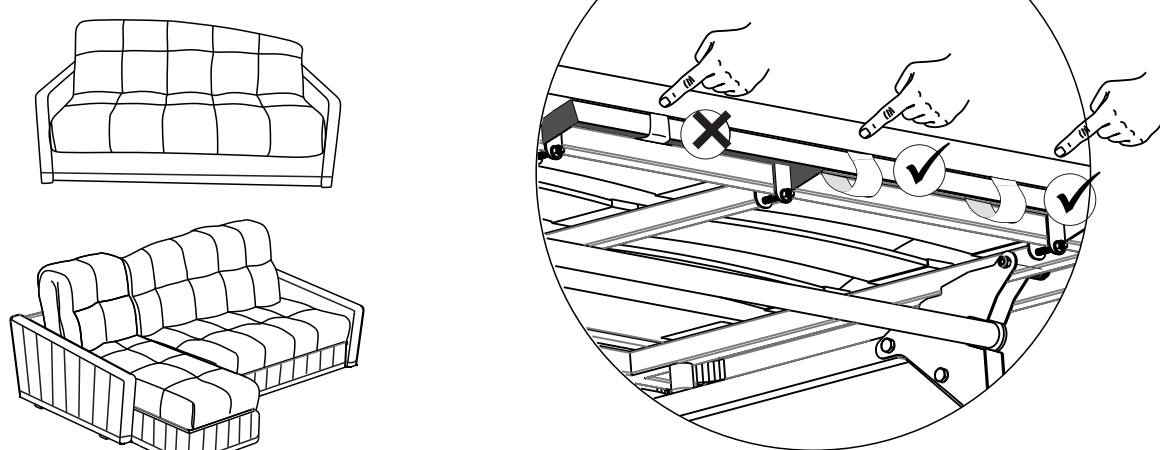

Ja dīvāna atzveltnes pozīcija ir šķība, atslābiniet kontaktlentes galvgalī

Ja starp matraci un roku balstu ir liela atstarpe, paceliet sēdekļa zonu un atslābiniet kontaktlentes

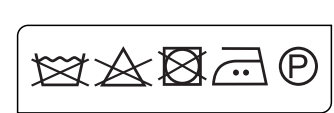
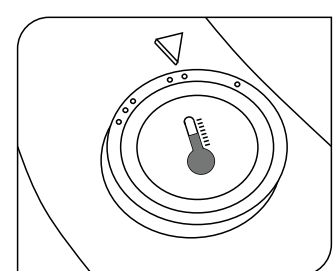
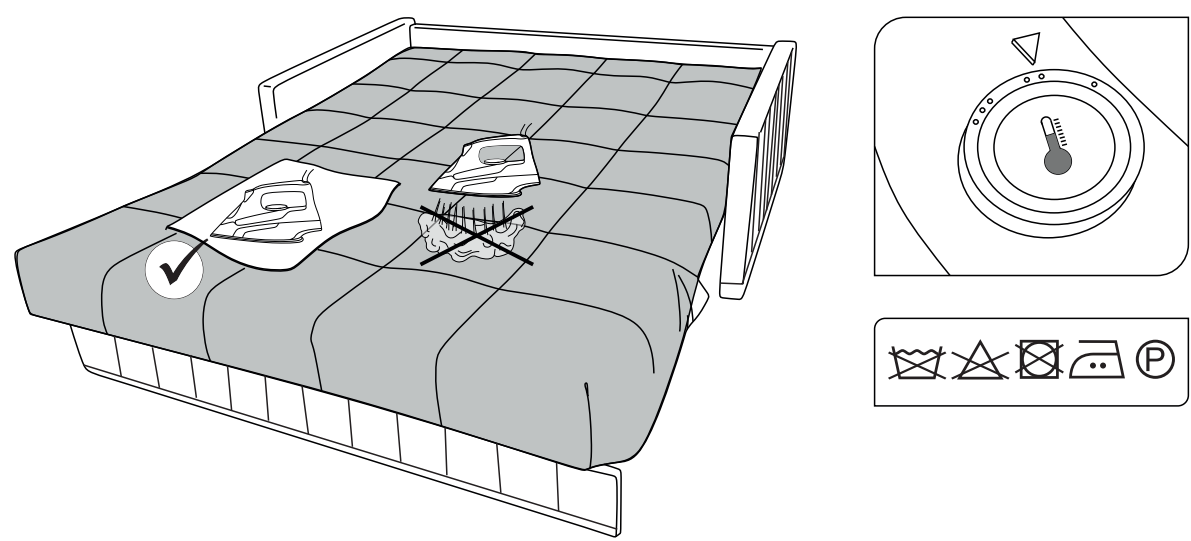
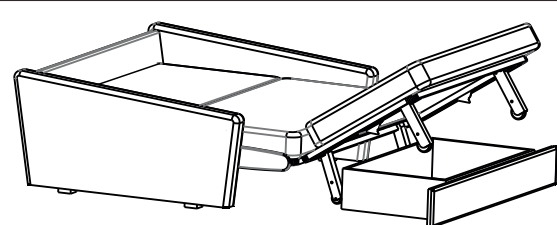
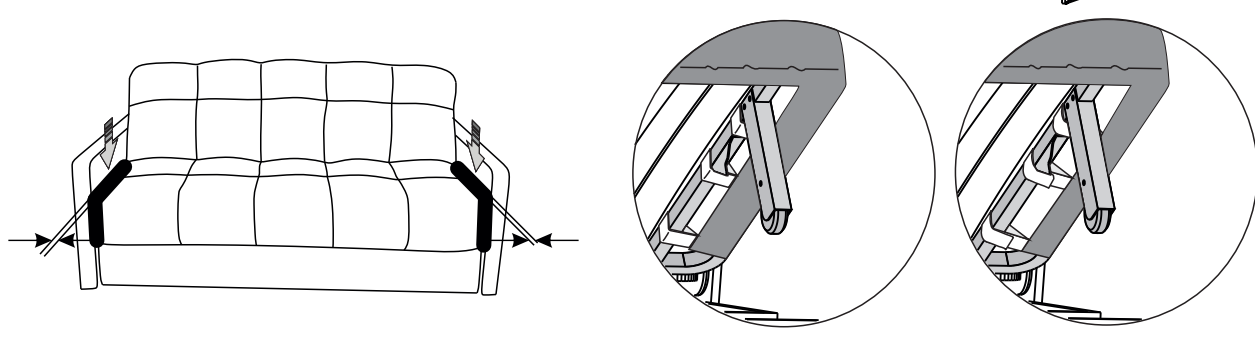



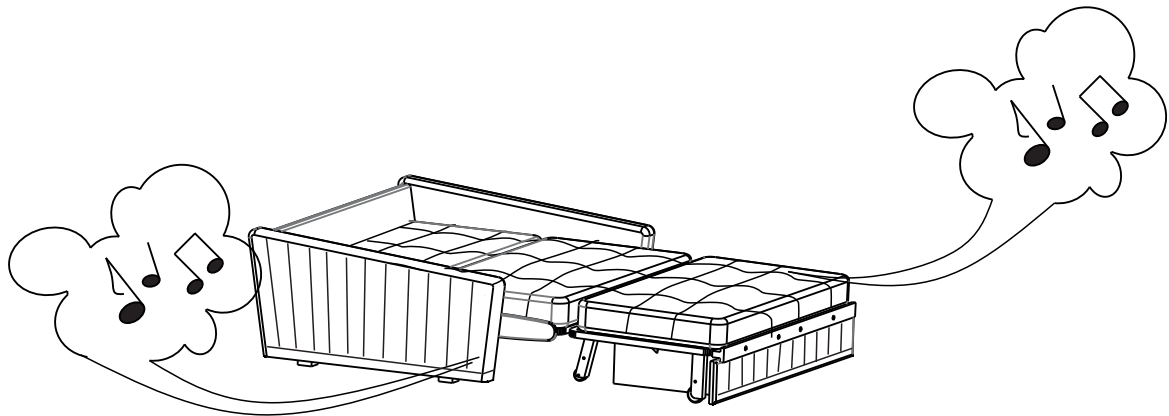

Atcerieties: mehānisma metāla elementu raksturīgā čīkstēšana pastāvīgas transformācijas laikā ir normāla situācija. Dīvāna centrā ir izturīga metāla konstrukcija, kas ikdienā dīvānu ļauj transformēt par gultu. Transformācijas un darbības laikā smērviela starp dažādām mehānisma daļām var izžūt un parādās metāla elementu berze vienam pret otru. Lai izvairītos no šīs berzes rašanās un mehānisma čīkstēšanas transformācijas vai darbības laikā, svarīgi ievērot ražotāja ieteikumus. Mehānisma čīkstēšanas gadījumā berzes elementi ir jāieeļļo

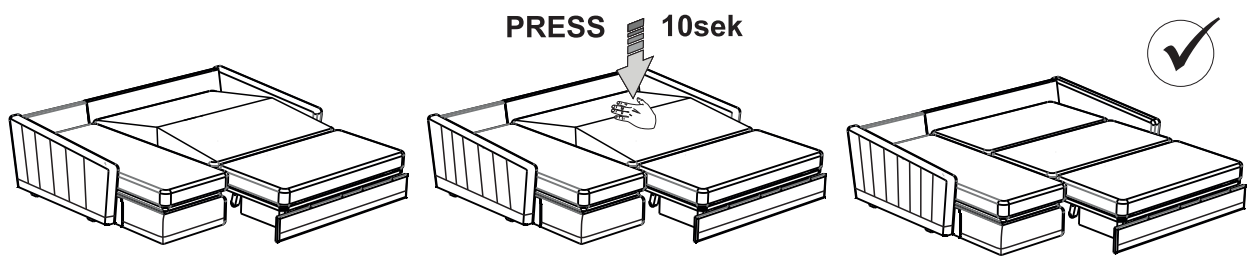
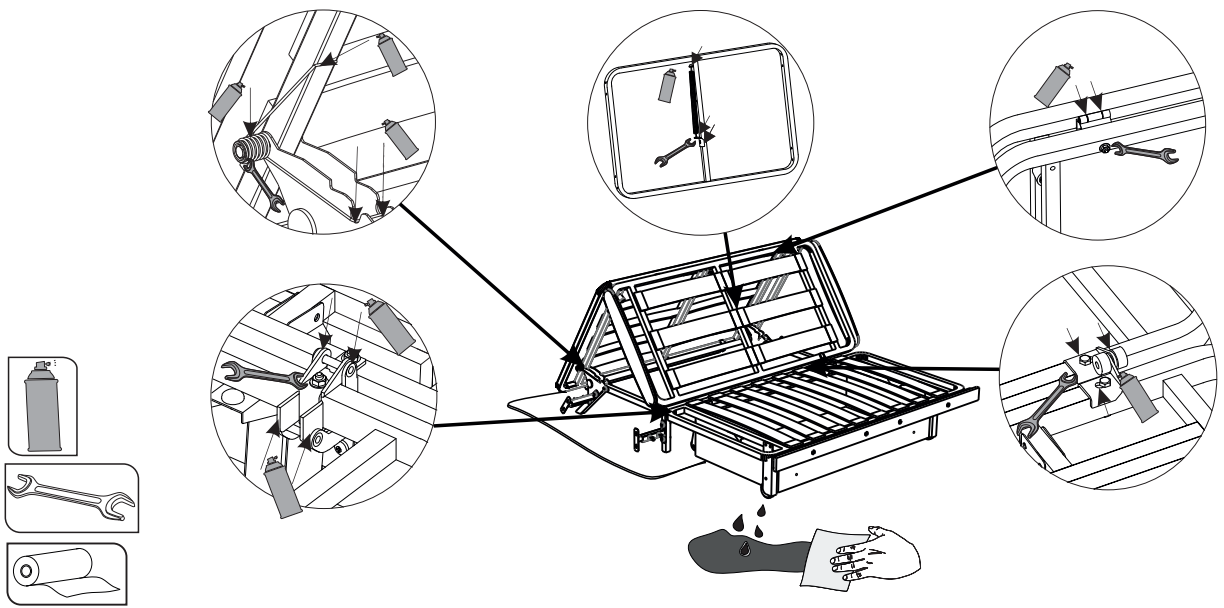





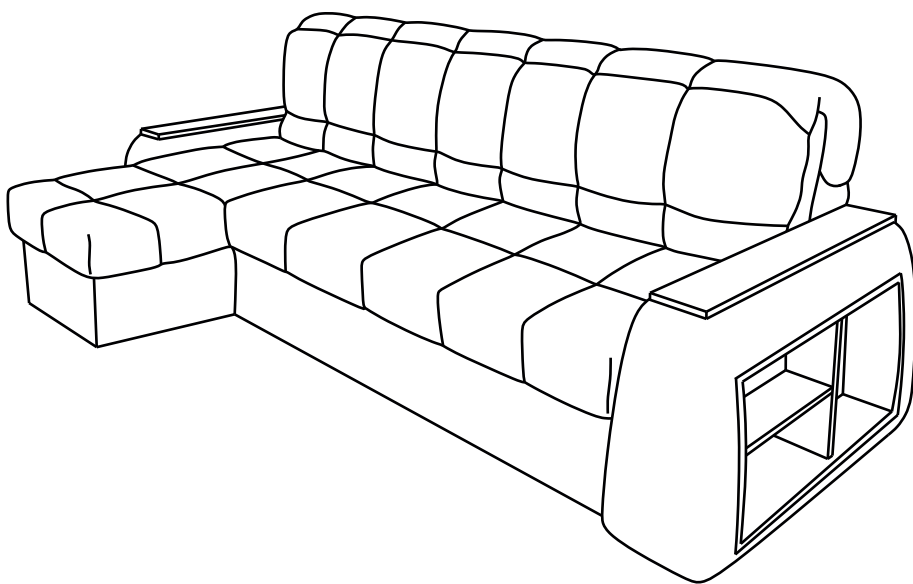
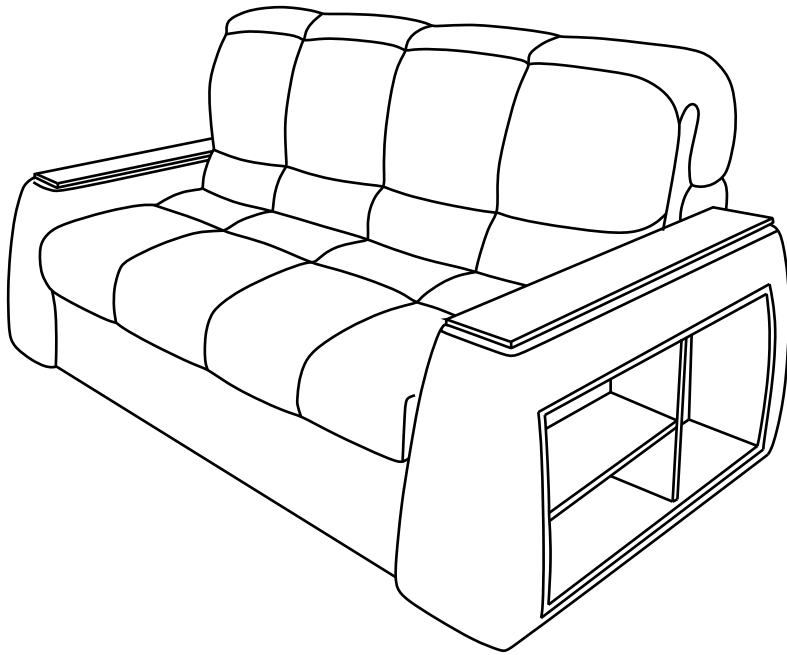

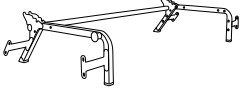

# SUNSET NOVA

EL



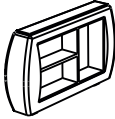
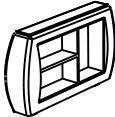
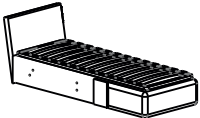

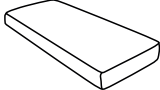

Sleep.8

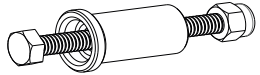
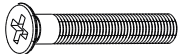

## Εξαρτήματα του καναπέ

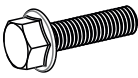
Συσκευασία	Εξάρτημα	Κωδικός εξαρτήματος	Ονομασία	Ποσότητα
Nº 1		D01	Μηχανισμός μετατροπής	1
		D26	Στήριξη μηχανισμού μετασχηματισμού	1
		D04	Πλάτη	1
		D05	Πλαίσιο	1
		D07	Κάλυμμα καναπέ καπιτονέ	1
			Συσκευασία με εξαρτήματα	1
			δείγμα υφάσματος, ονομαστική ταμπέλα	1
Nº 2		D06	Υποβραχιόνιο	1
Nº 3		D06	Υποβραχιόνιο	1
Nº 4 επιπρόσθετη επιλογή κατά την παραγγελία του καναπέ με γωνία		D14	Γωνία	1
		D11	Μαξιλάρι γωνίας	1
		D08	Κάλυμμα γωνίας, δείγμα του υφάσματος της γωνίας	1
			Συσκευασία με εξαρτήματα	1
			δείγμα υφάσματος, ονομαστική ταμπέλα	1
Παρέχεται ξεχωριστά		D20	Στρώμα	1
		D21	Στρώμα καναπέ	1

### Κατάλογος εξαρτημάτων του καναπέ

Συσκευασία	Εξάρτημα	Κωδικός εξαρτήματος	Όνομασία	Ποσότητα
Συσκευασία με εξαρτήματα		DF02 DF15 DF16	Βίδα M6x65 Βύσμα πλαστικό Περικόχλιο M6 (αυτοελεγχ.)	2
		DF11	Βίδα με βυθιζόμενη κεφαλή M6x30	3
		DF31	Ελατήριο με γάντζους	2
		DF06	Βίδα M8x45	4
		DF56	Βίδα M8x30	8
		DF42	Ροδέλα M8	4

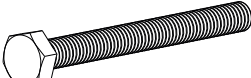

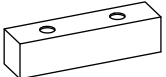
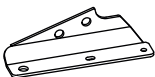
### Κατάλογος εξαρτημάτων του γωνιακού καναπέ

Συσκευασία	Εξάρτημα	Κωδικός εξαρτήματος	Όνομασία	Ποσότητα
Συσκευασία με εξαρτήματα		DF30	Ελατήριο στη γωνία (μόνο για μικρή γωνία)	2
		DF09	Βίδα M8x80	10
		DF19	Παξιμάδι M8	6
		DF42	Ροδέλα M8	14
		DF74	Επένδυση γωνίας M8	4
		DF75	Διακοπή μηχανισμού	2

Πριν από τη συναρμολόγηση:

- 1) Ελέγξτε την εμφάνιση και την ακεραιότητα των εξαρτημάτων στη συσκευασία!** Οι αξιώσεις για ζημιά γίνονται αποδεκτές μόνο για προϊόντα ΧΩΡΙΣ ίχνη συναρμολόγησης.
- 2) Αφήστε τη συσκευασία και τις οδηγίες μέχρι το τέλος της συναρμολόγησης!** Εάν εντοπίσετε ένα ελάττωμα και ένα ημιτελές προϊόν κατά τη διαδικασία συναρμολόγησης, είναι απαραίτητο να διατηρήσετε τη συσκευασία έως ότου φύγει ο εκπρόσωπος της εμπορικής εταιρείας.
- 3) Ελέγξτε τον αριθμό εξαρτημάτων και εξαρτημάτων στη λίστα.** Ο κατασκευαστής διατηρεί το δικαίωμα να κάνει αλλαγές στο σχεδιασμό του προϊόντος, να αντικαταστήσει το υλικό και το υλικό με παρόμοια που δεν επηρεάζουν την εμφάνιση και δεν επηρεάζουν τις λειτουργικές ιδιότητες του προϊόντος. Σε περίπτωση ατελούς ή θραύσης, κάντε κύκλο στον αριθμό του ελλείποντος τμήματος και αναφέρετέ το στο κατάστημα για να το αντικαταστήσετε.
- 4) Ακολουθήστε τη διαδικασία συναρμολόγησης που παρέχεται σε αυτό το εγχειρίδιο!** Η μη τήρηση των οδηγιών συναρμολόγησης και λειτουργίας ακυρώνει την εγγύηση του κατασκευαστή.
- 5) Για να εγκαταστήσετε έναν καναπέ-κρεβάτι, επιλέξτε ένα επίπεδο πάτωμα!** Σε καμπύλες δαπέδου και ψηλά χαλιά αποκλίσεις στην εργασία του μηχανισμού μετατροπής ενός καναπέ-κρεβάτι, είναι δυνατές παραμορφώσεις της μορφής ενός προϊόντος.
- 6) Συναρμολογήστε τον καναπέ-κρεβάτι μαζί.** Μετακινήστε προσεκτικά όλα τα μέρη, χωρίς σπασμούς, στοιβάζονται σταθερά, αποφύγετε τις πτώσεις και τα χτυπήματά τους!
- 7) Μετακινήστε ελαφρά τα έπιπλα και τα μέρη του.** Αυτό θα εξαλείψει τις παραμορφώσεις και τις βλάβες.
- 8) Φροντίστε να λιπάνετε το μηχανισμό ανύψωσης κατά τη συναρμολόγηση σύμφωνα με τις οδηγίες!** Αυτό θα αποτρέψει την πρόωρη τριβή. Επαναλάβετε τη λίπανση, σφίξτε σαφώς χαλαρά μπουλόνια και παξιμάδια τουλάχιστον μία φορά κάθε έξι μήνες.

**Για τη συναρμολόγηση θα χρειαστείτε:**

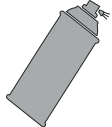
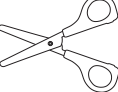
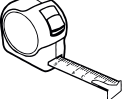
	Κατσαβίδι εγκάρσιας κεφαλής
	Γαλλικό κλειδί Νο13 x 1 Γαλλικό κλειδί Νο10 x 2
	Χαρτοπετσέτα
	Λιπαντικό σπρέι σιλικόνης
	Ψαλίδι
	Ρουλέτα

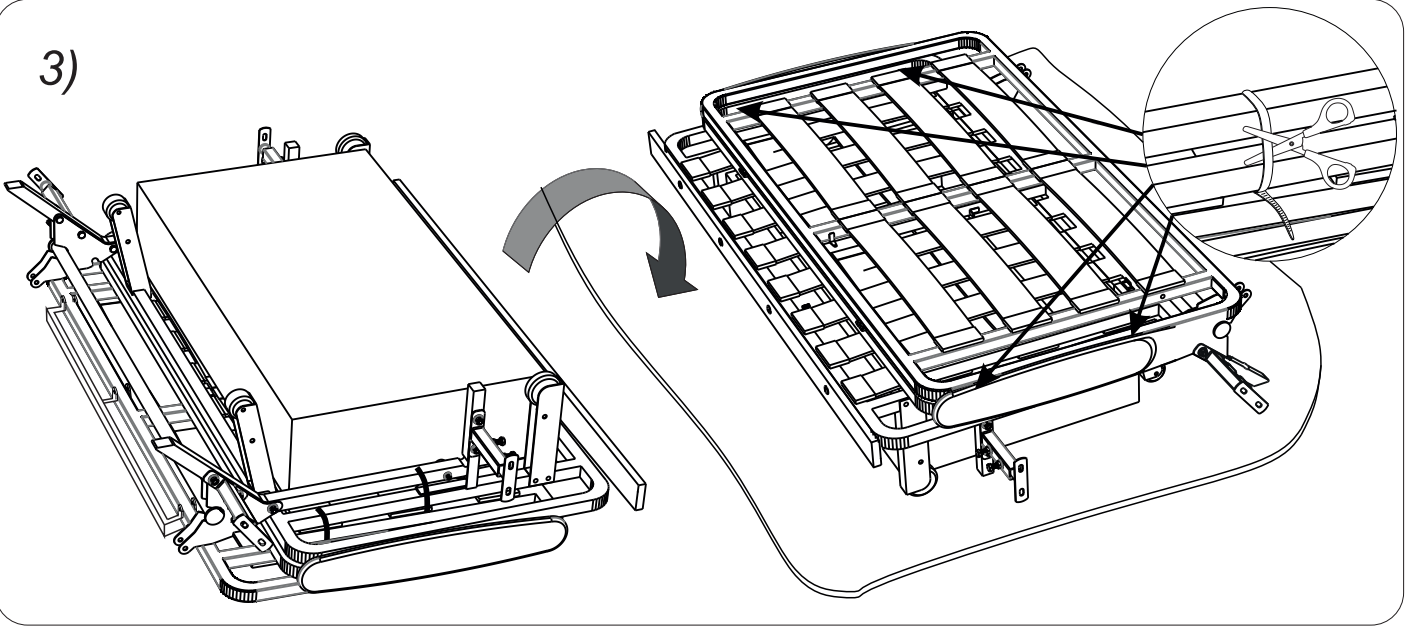
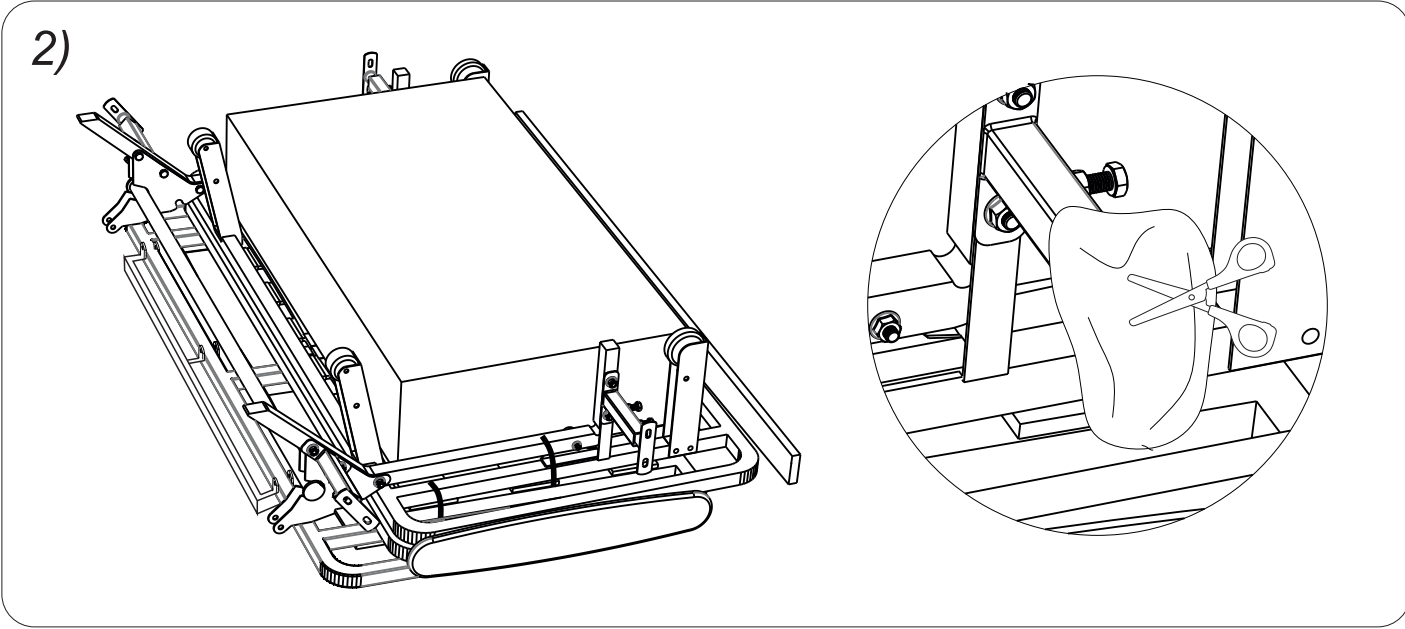
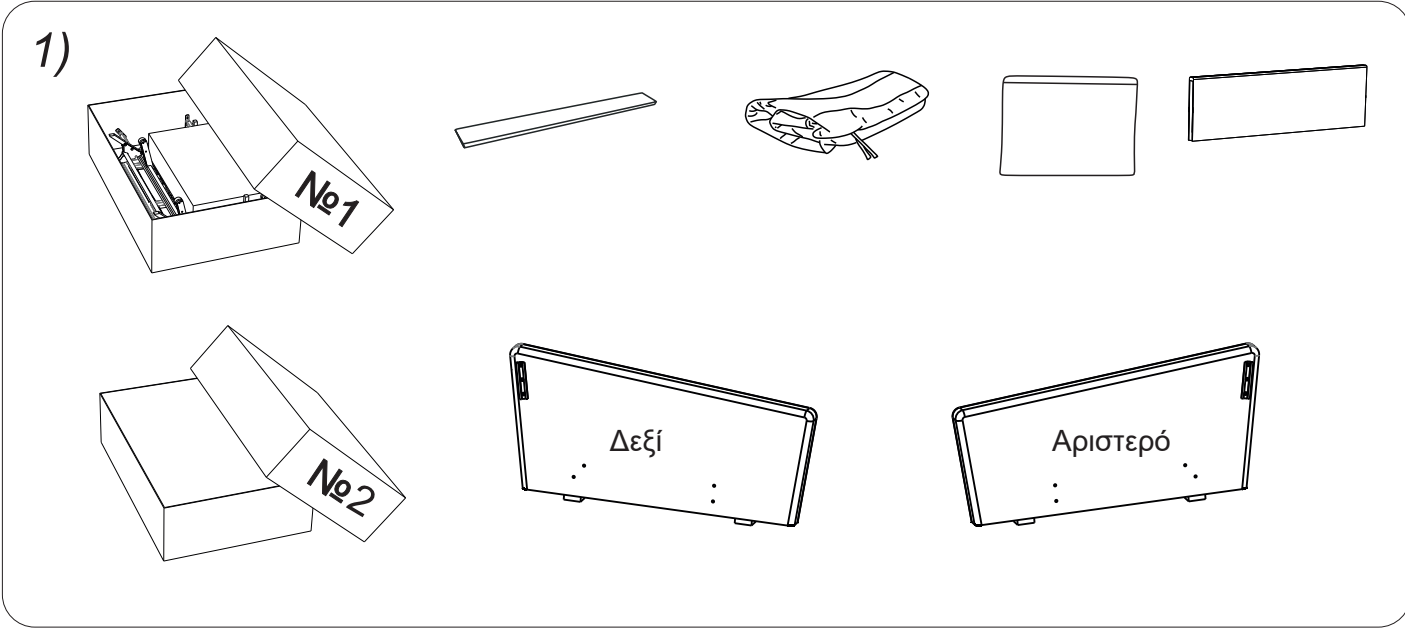

4)

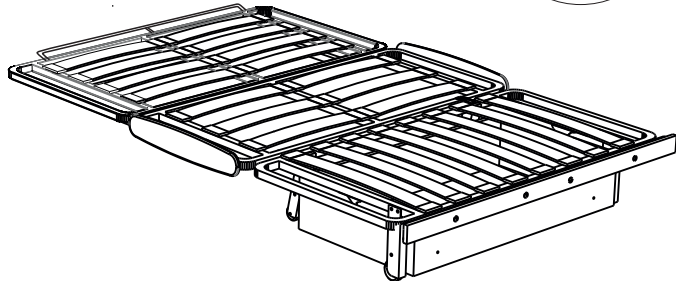
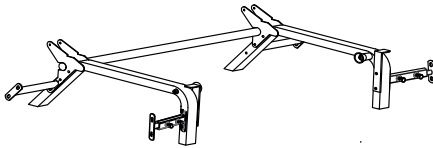
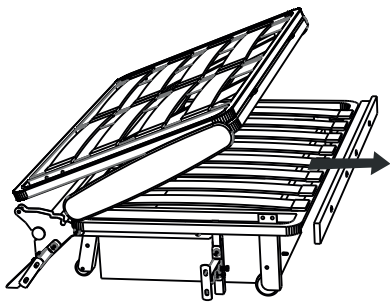

Να αφαιρέσετε το πλαίσιο από τη βάση

5)

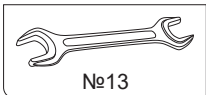
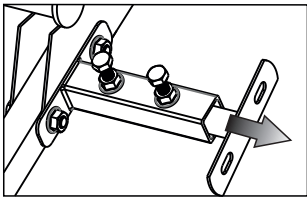
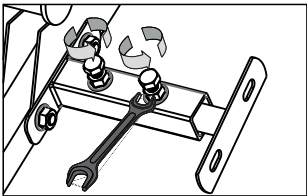

№13

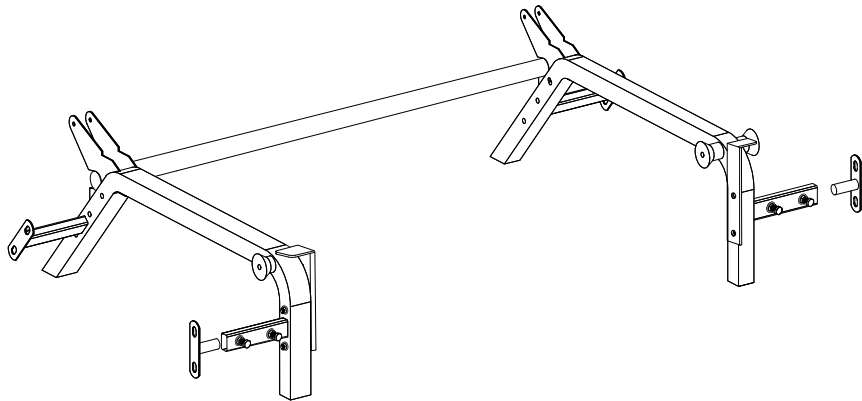

6)

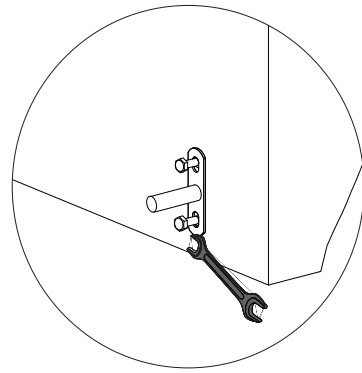
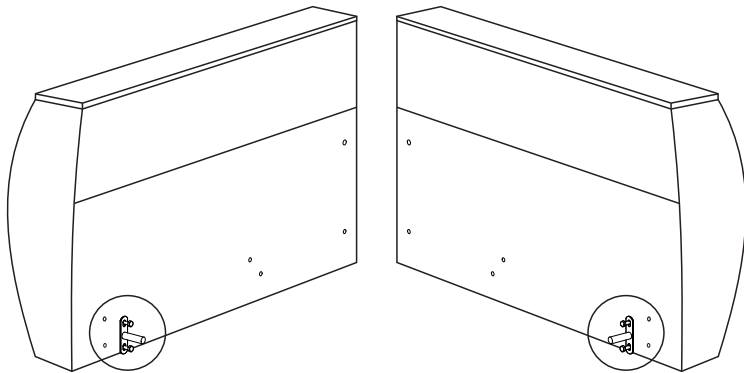

DF56

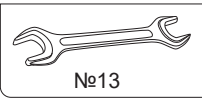

№13

Κατά τη συναρμολόγηση της γωνίας το υποστήριγμα να τοποθετηθεί σε ένα από τα υποβραχιόνια (από την πλευρά, αντίθετη στον τοίχο)



7)

Να μην σφίγγετε πολύ

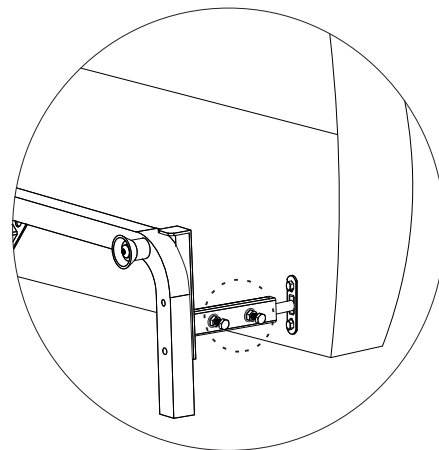
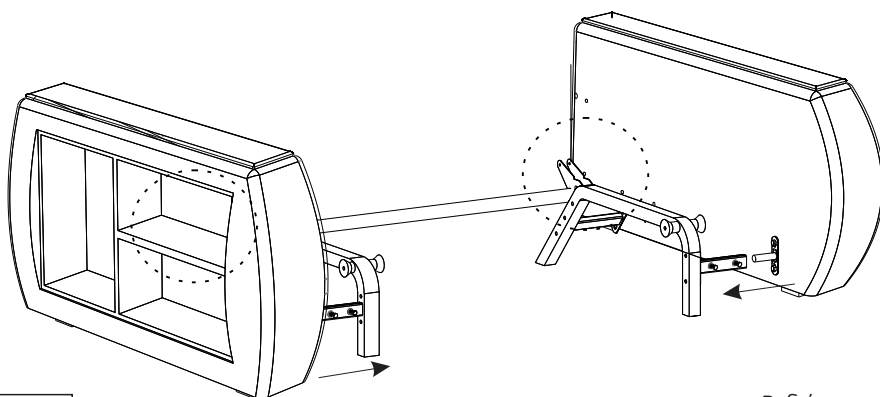

DF56

Βιδώστε τα οπίσθια υποστηρίγματα.  
Να μην σφίγγετε τις βίδες των πρόσθιων  
υποστηριγμάτων

8)

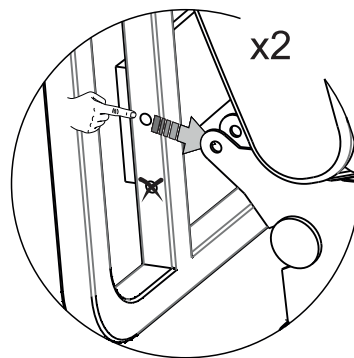
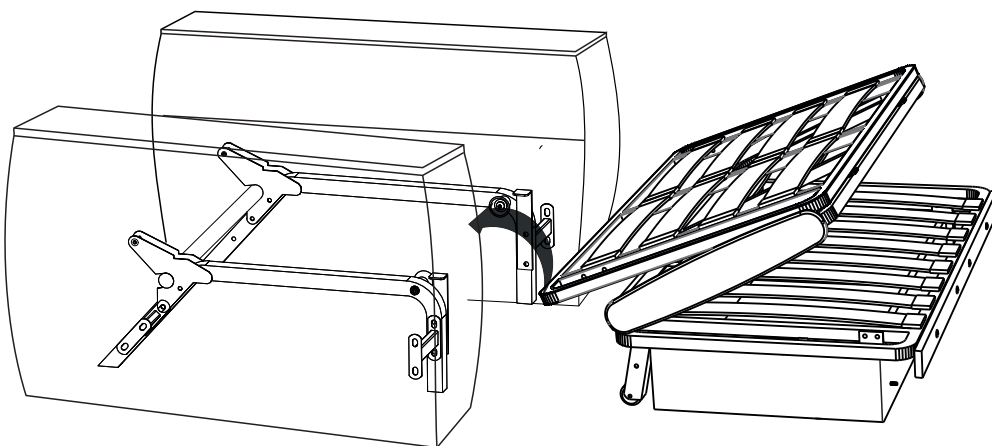

9)

x2

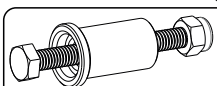
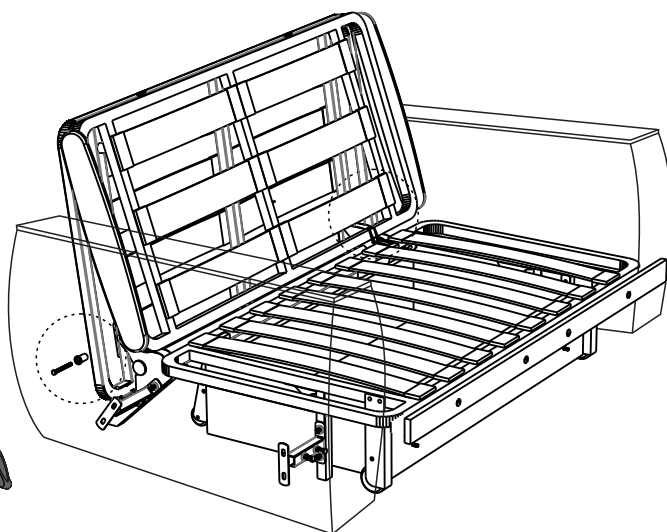
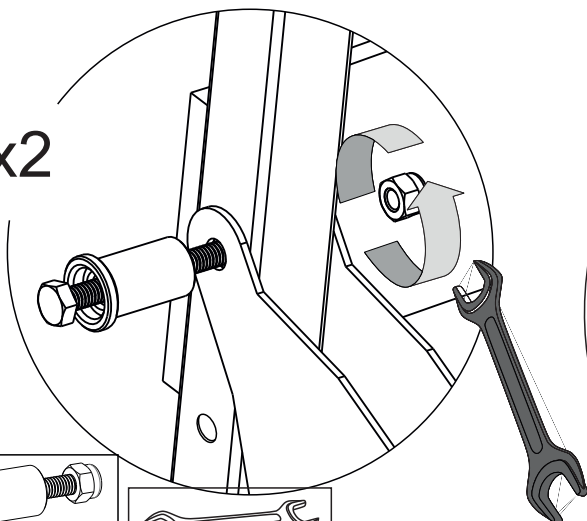

DF02 DF 15 DF16

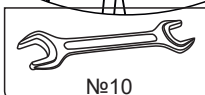

№10

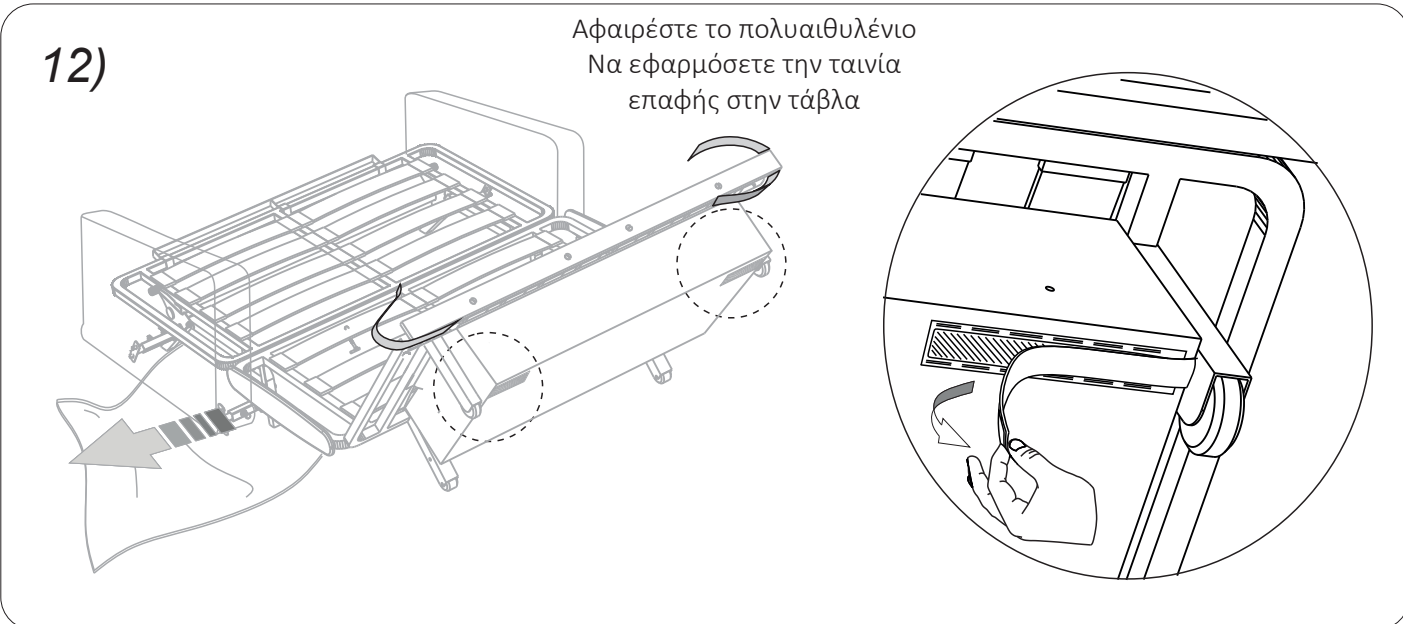
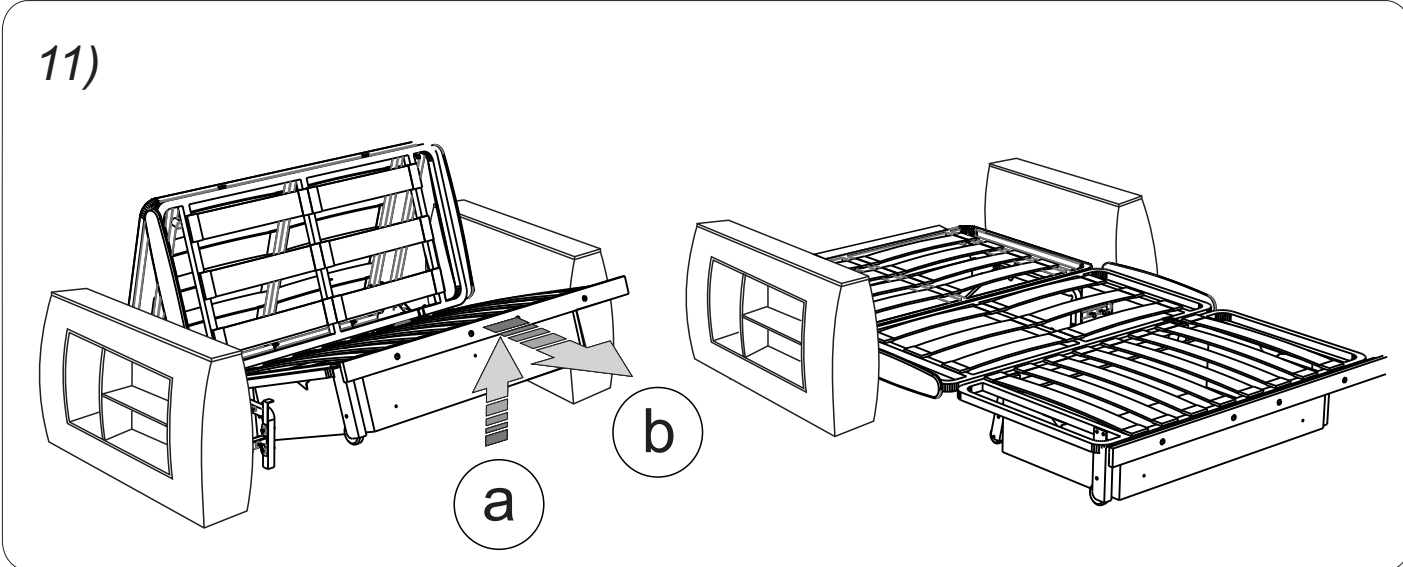
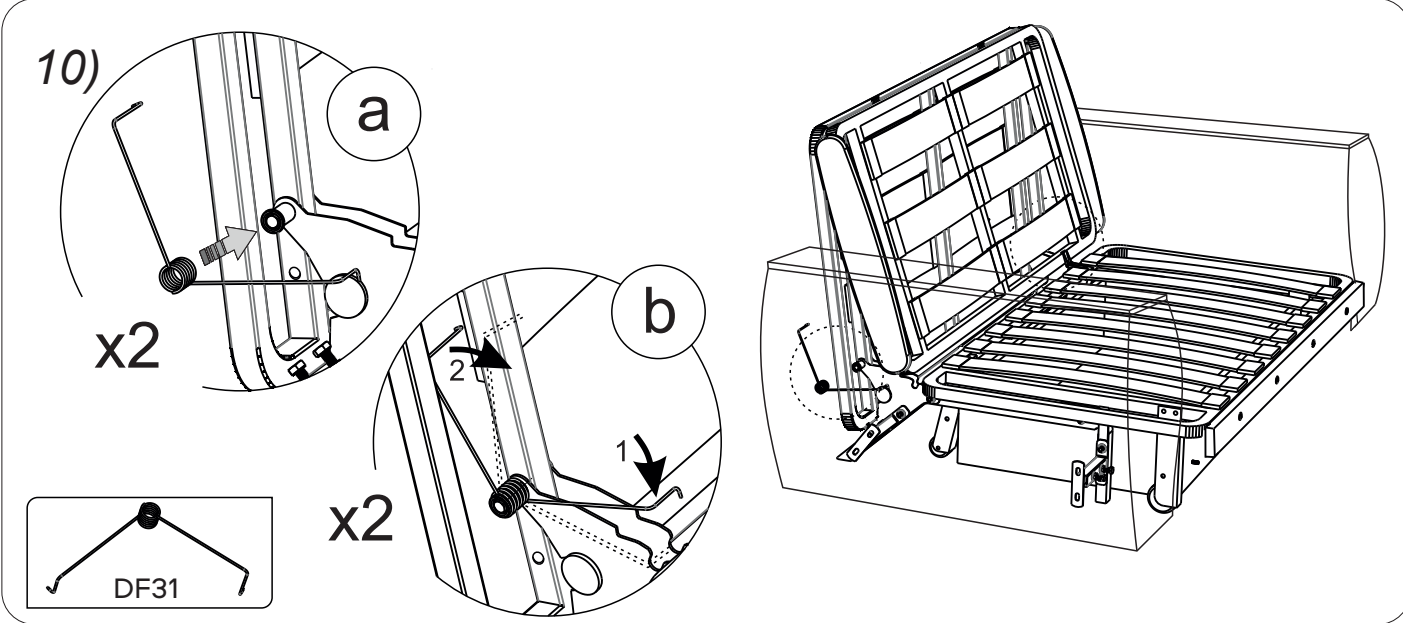

13)

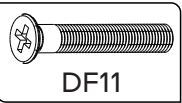
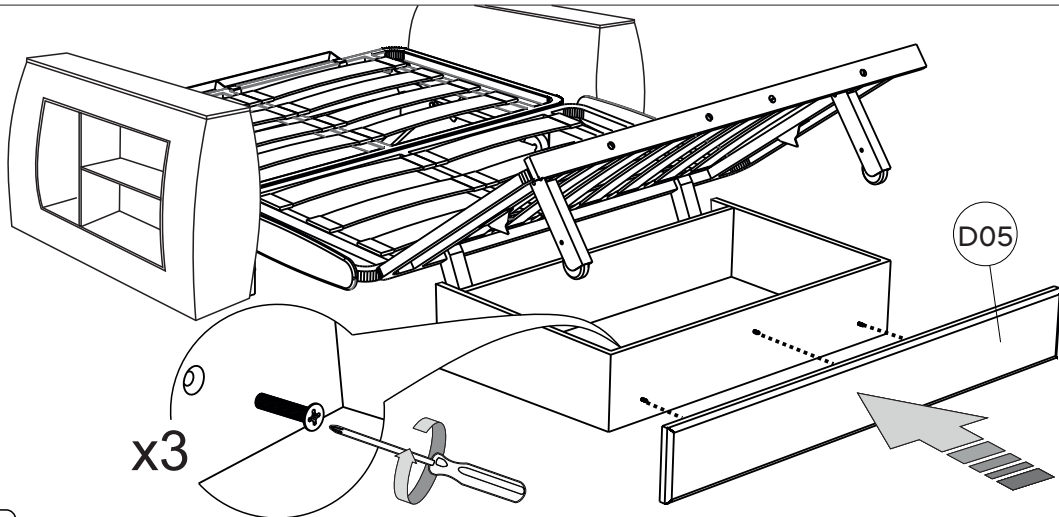

Τοποθετήστε την μεμβράνη από τη συσκευασία του καναπέ στον μηχανισμό για να προστατέψετε το κάλυμμα από τη λίπανση.

14)

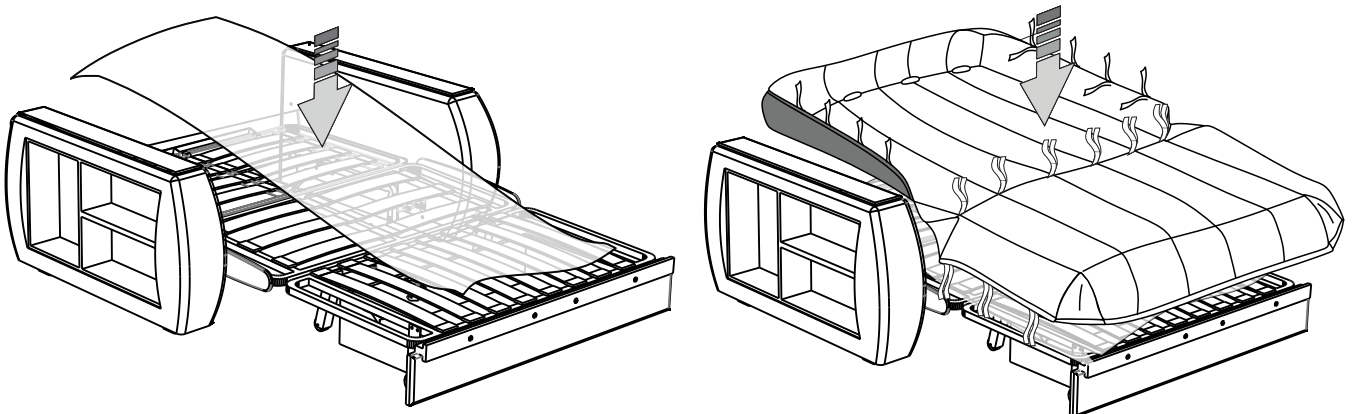

Να τοποθετήσετε τη μεμβράνη από τη συσκευασία του καναπέ πάνω στο μηχανισμό ώστε να προστατέψετε το κάλυμμα από το λιπαντικό.

15)

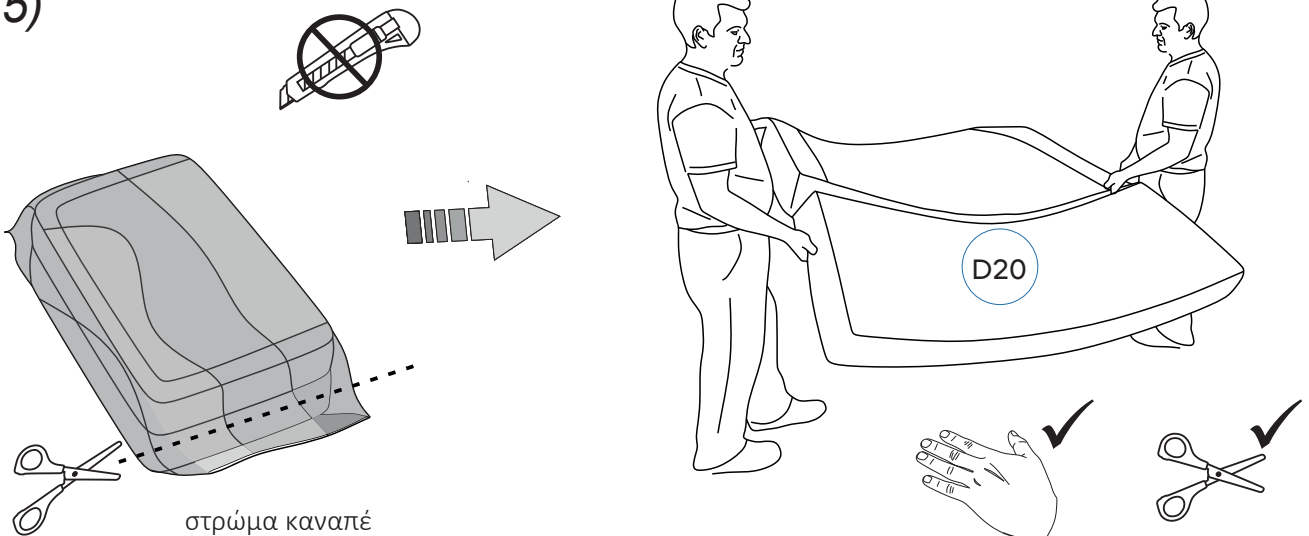

στρώμα καναπέ

16)

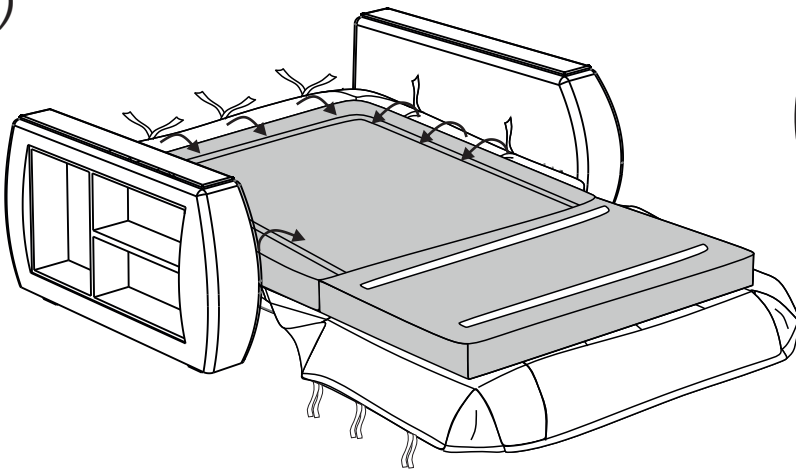

Να ισιώσετε τις ραφές και τις γωνίες του στρώματος και του καλύμματος. Στην κεφαλή να περάσετε τις συνδετικές ταινίες στις σπές μέσα στο κάλυμμα.

17)

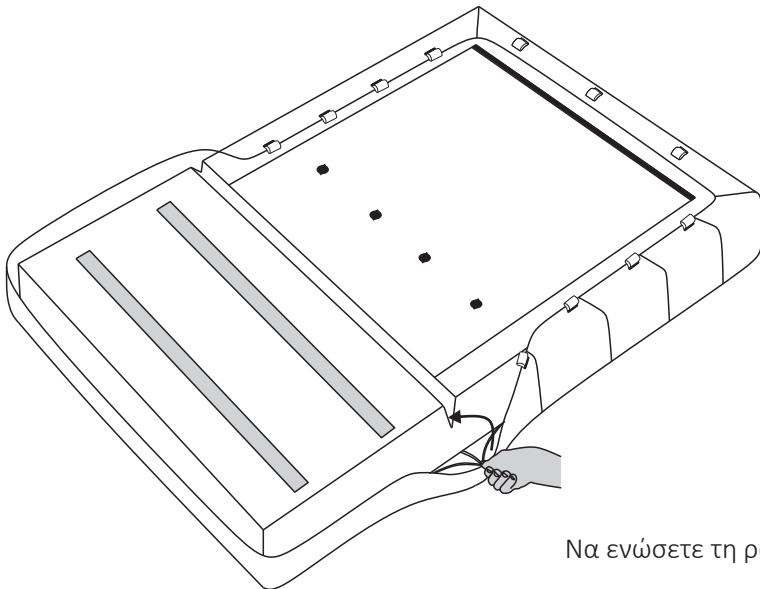

Να ενώσετε τη ραφή του καλύμματος και του στρώματος

18)

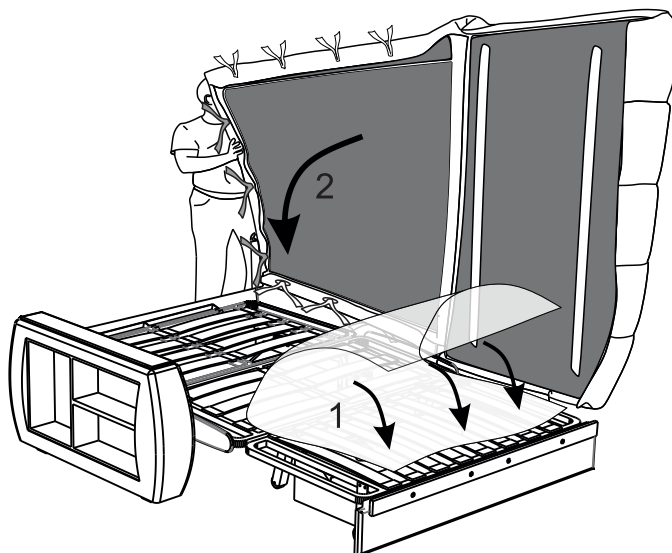

19)

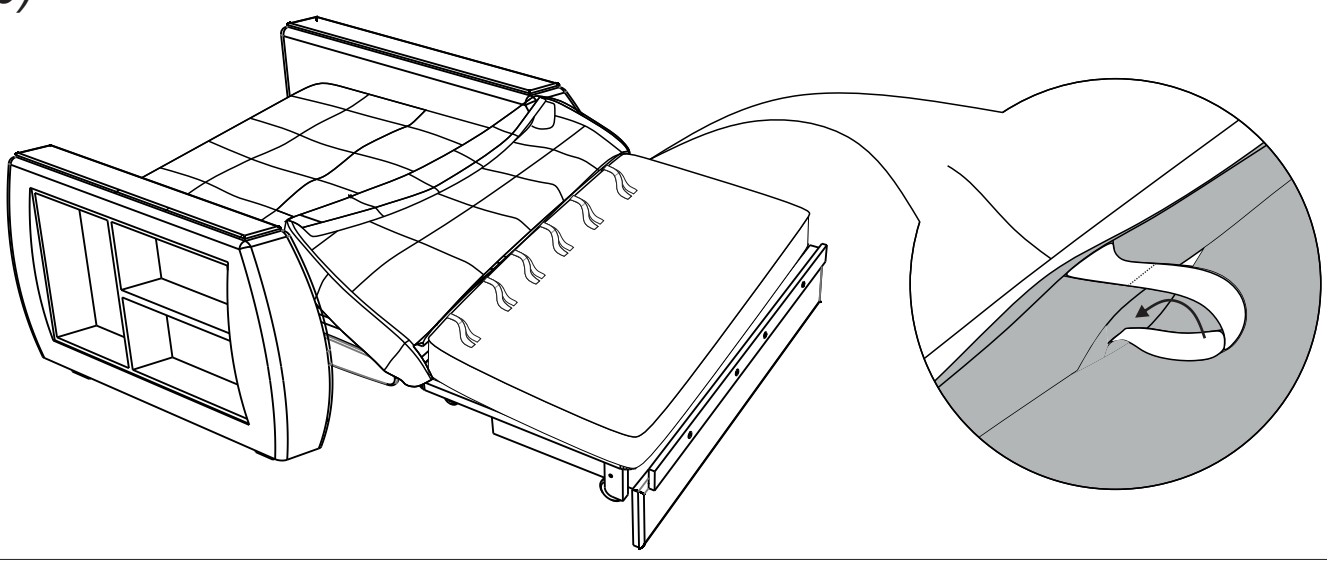

20)

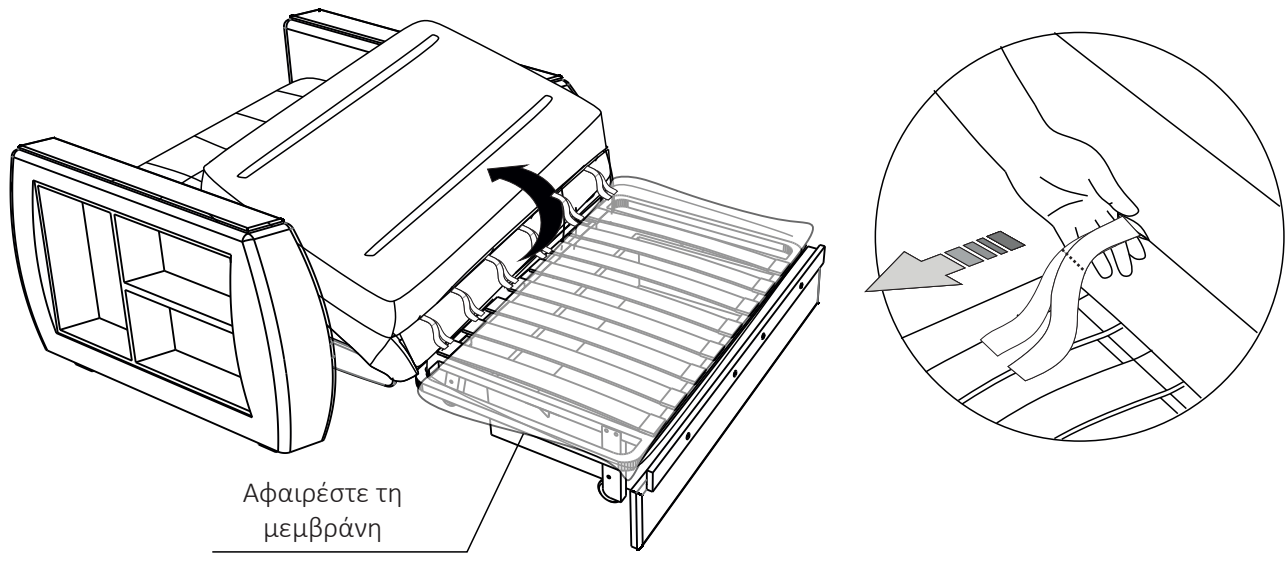

Αφαιρέστε τη μεμβράνη

21)

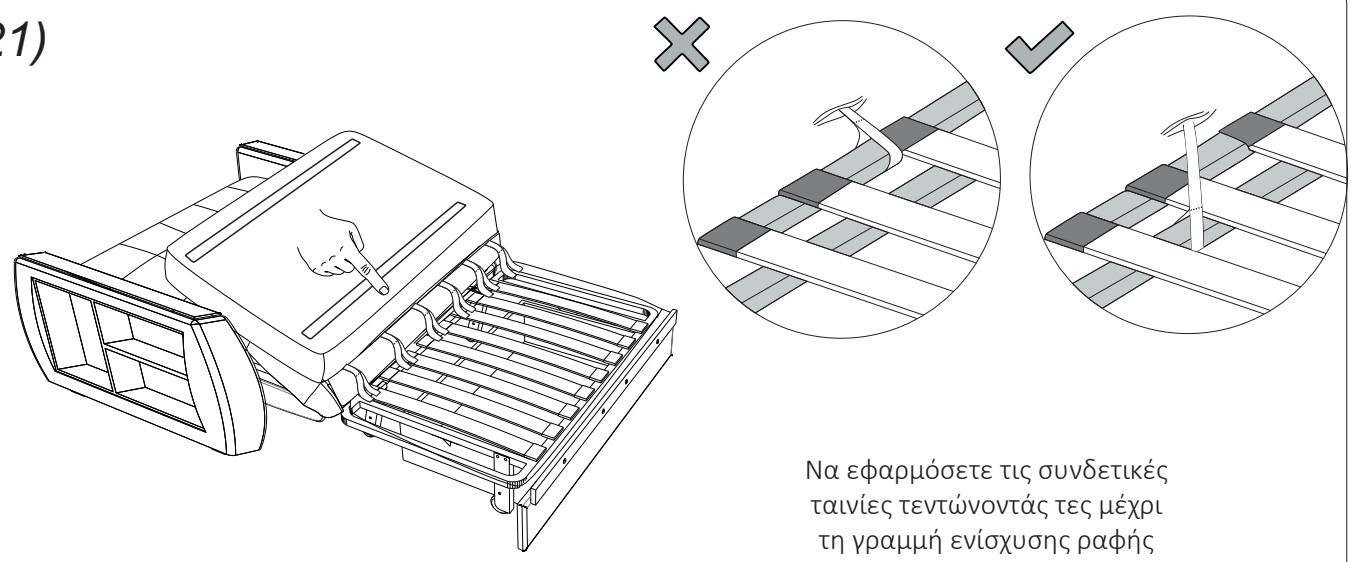

Να εφαρμόσετε τις συνδετικές ταινίες τεντώνοντάς τες μέχρι τη γραμμή ενίσχυσης ραφής



22)

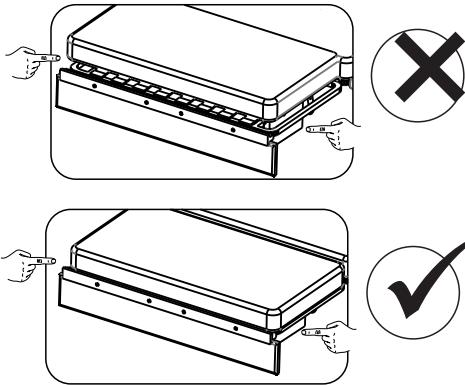

Το στρώμα δεν πρέπει να προεξέχει από την άκρη της ράγας για περισσότερο από 1 εκ

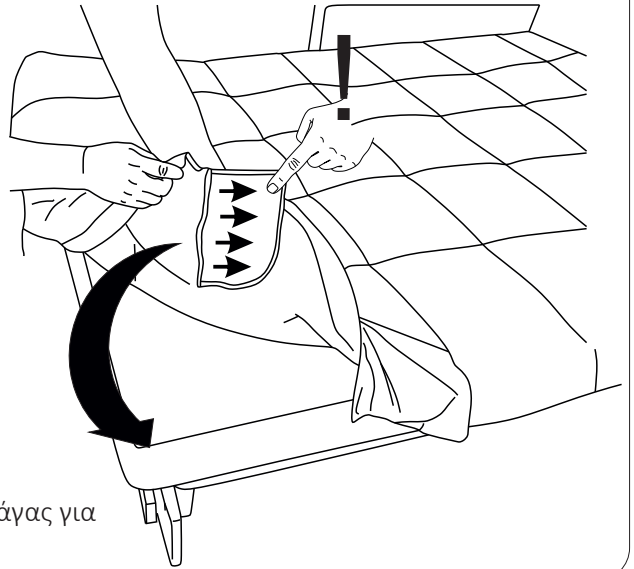

23)

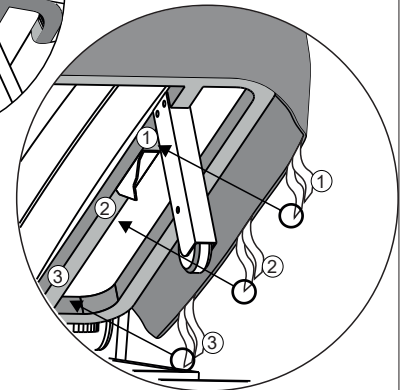
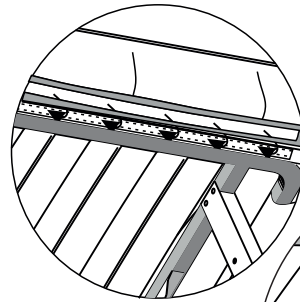
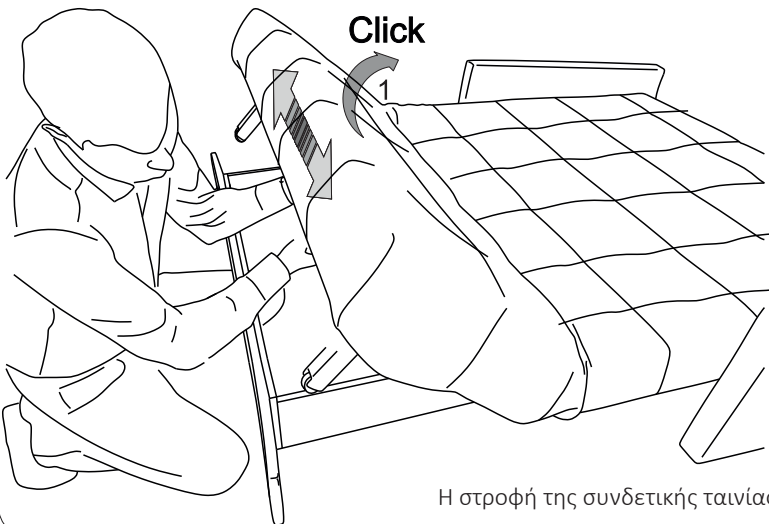

Η στροφή της συνδετικής ταινίας — ολόκληρος κύκλος

24)

Να μαζέψετε τα περισευμένα μέρη του καλύμματος στο σημείο της άκρης ώστε να διευκολύνετε τον μετασχηματισμό

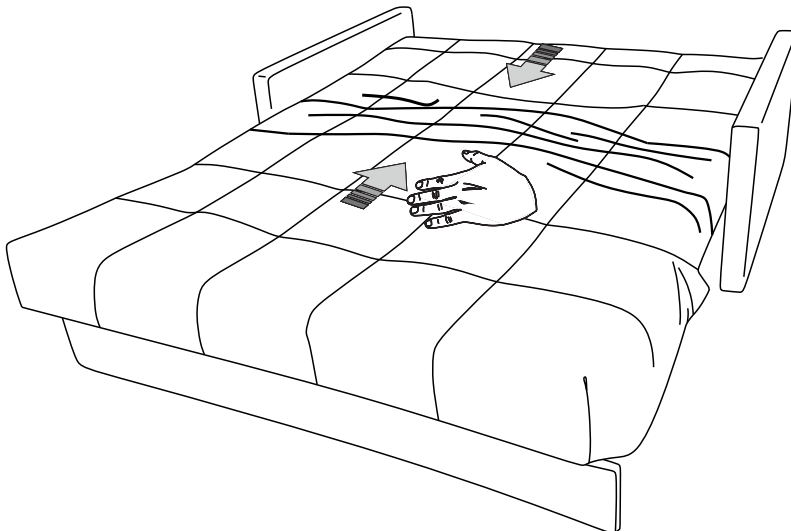

25)

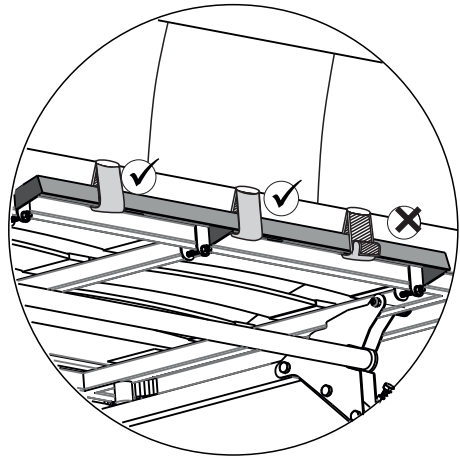
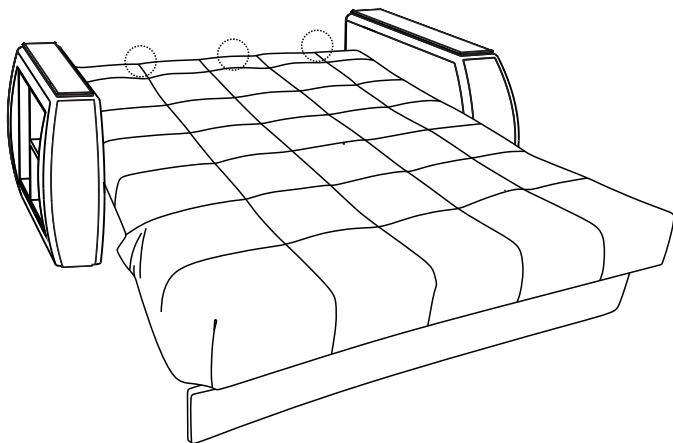

26)

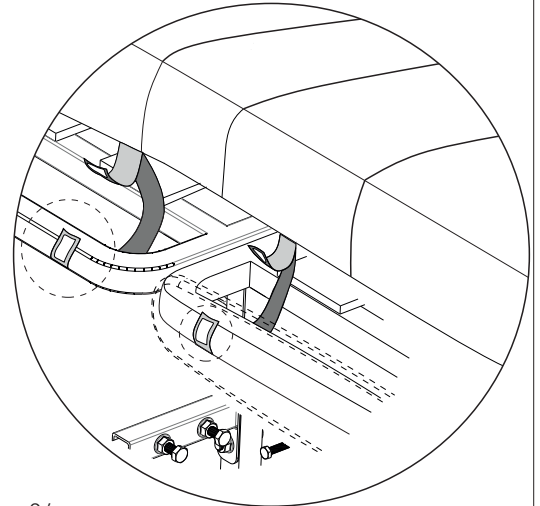
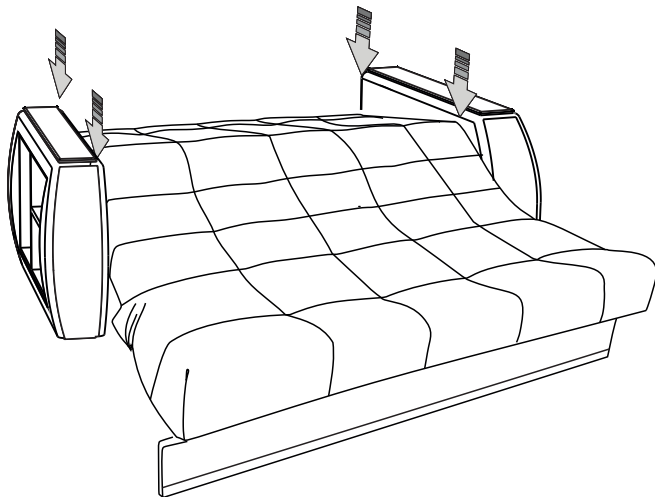

Μετασηματίστε τον καναπέ σε μισάνοιχτη θέση.  
Στη στερέωση οι συνδετικές ταινίες πρέπει να είναι πλήρως τεντωμένες

27)

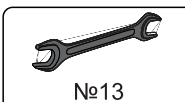
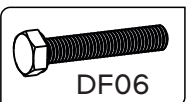
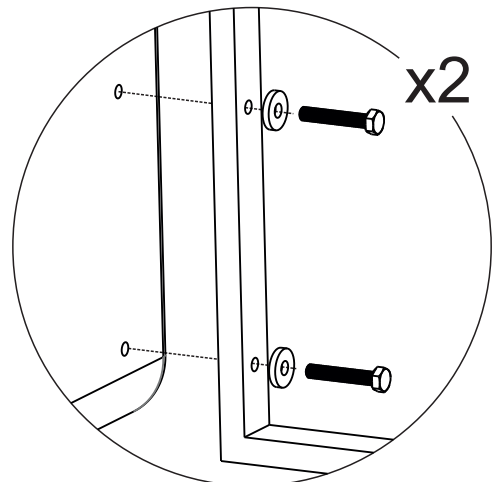
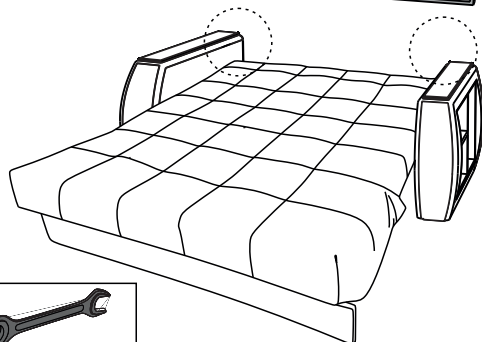
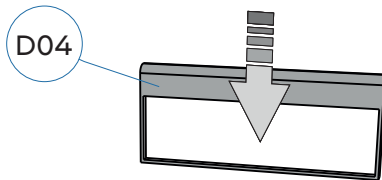



Εάν υπάρχει γωνία να προχωρήσετε στη συναρμολόγηση του καναπέ με γωνία

28)

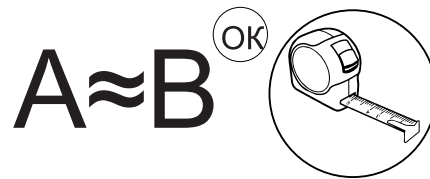
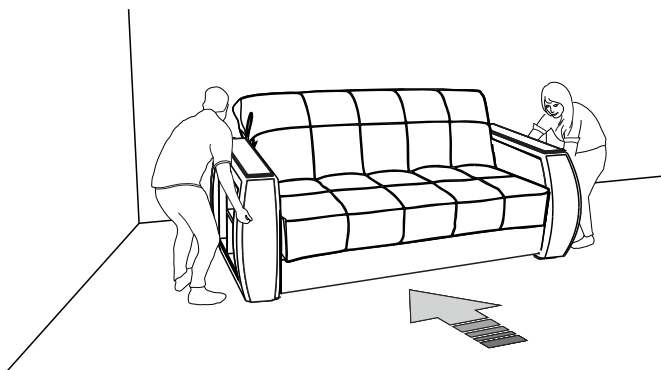

Τοποθετήστε τον καναπέ στη θέση όπου θα βρίσκεται μόνιμα

29)

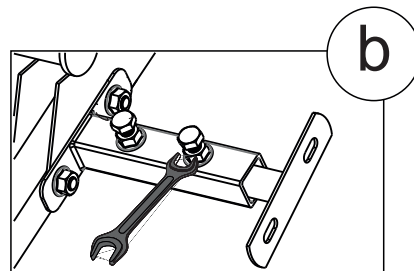
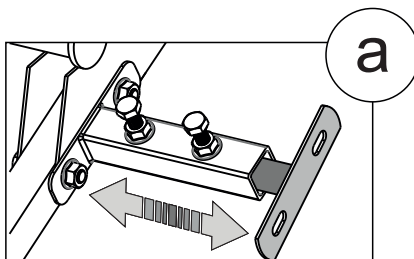
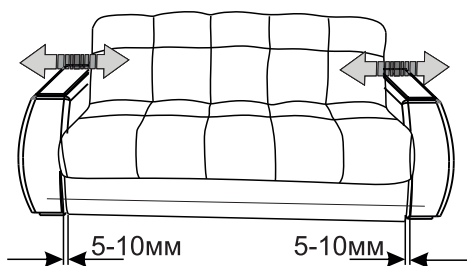

Σφίξτε!

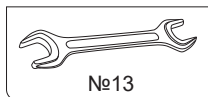

30)

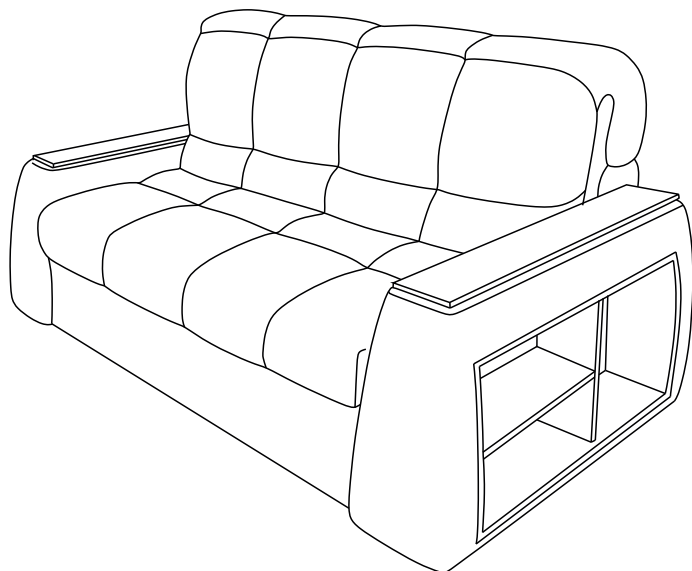

31)

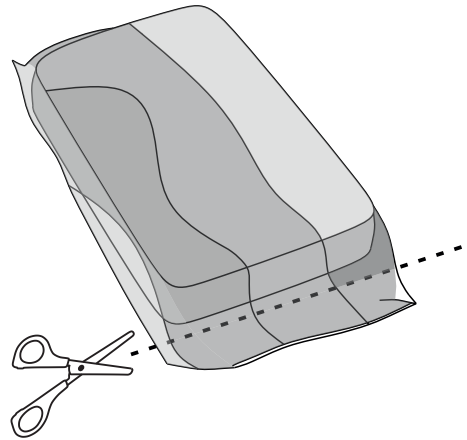
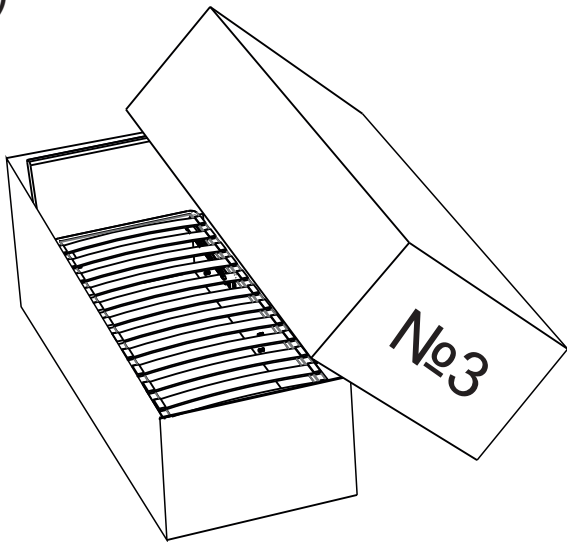

32

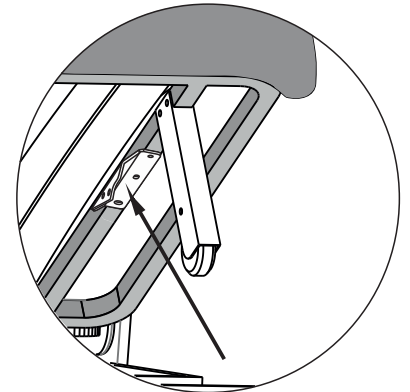
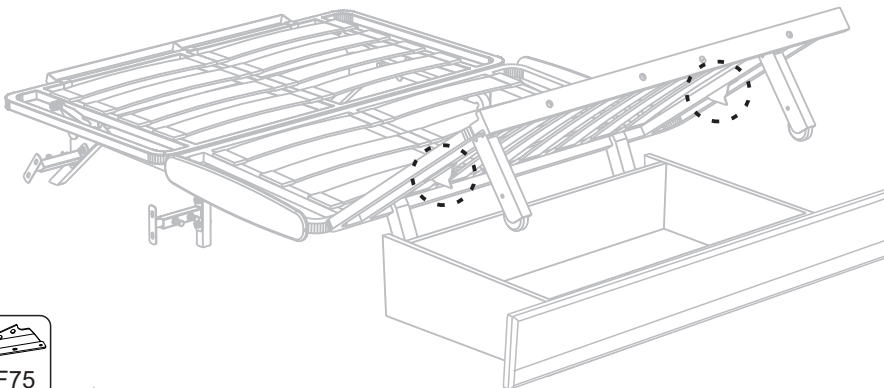

33)

Τα ελατήρια εφαρμόζονται μόνο στη μικρή γωνία

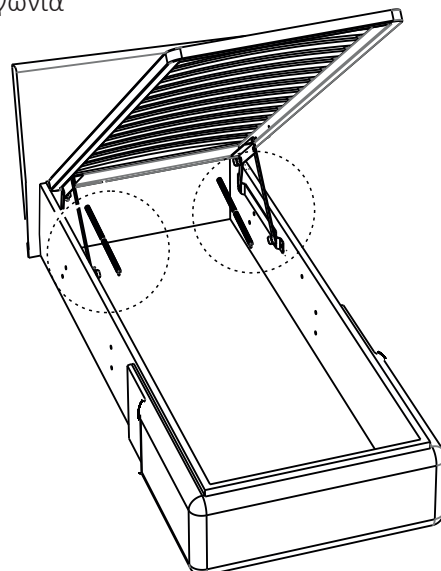
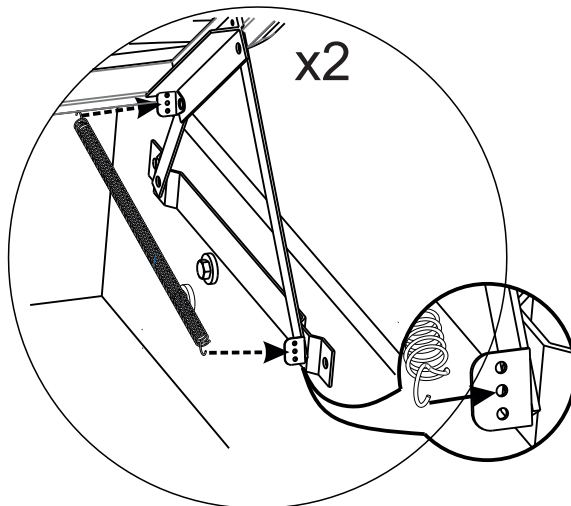

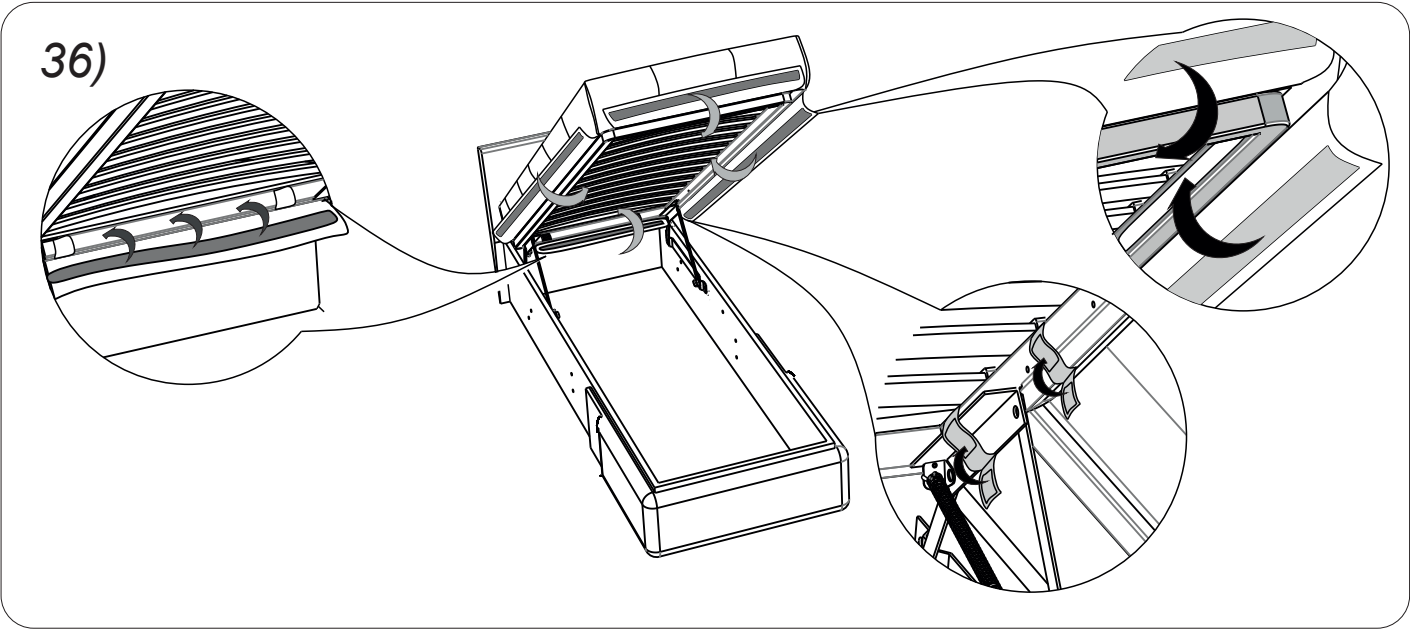
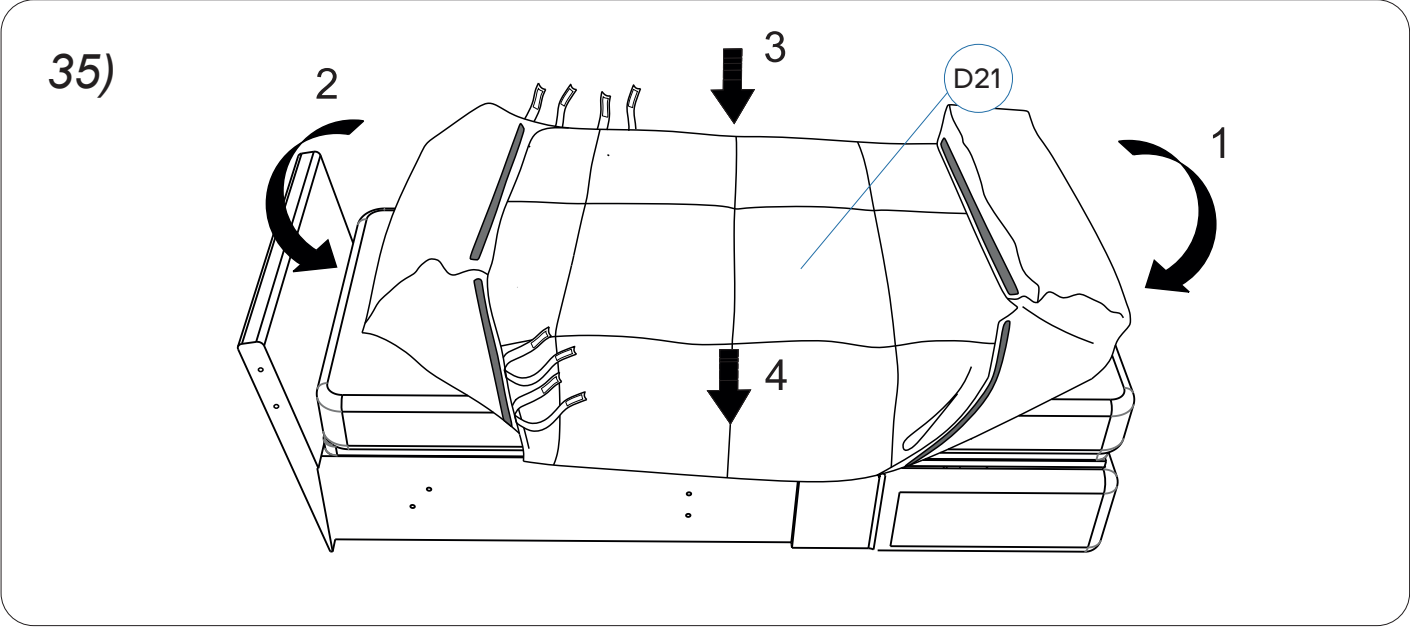
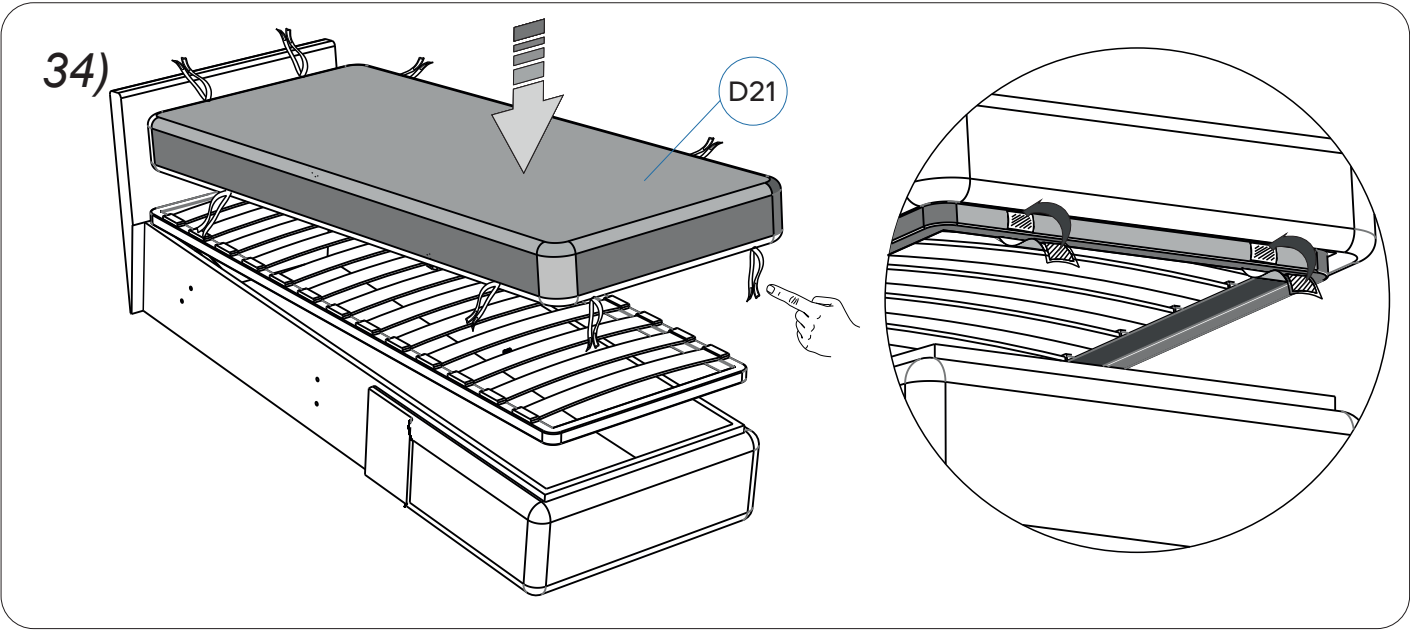

37)

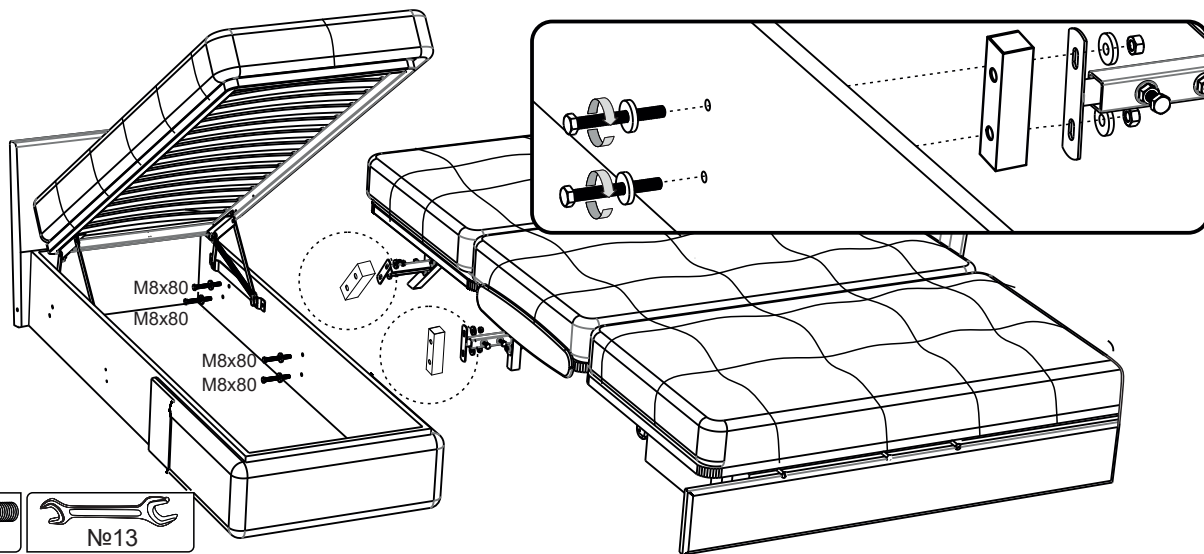

38)

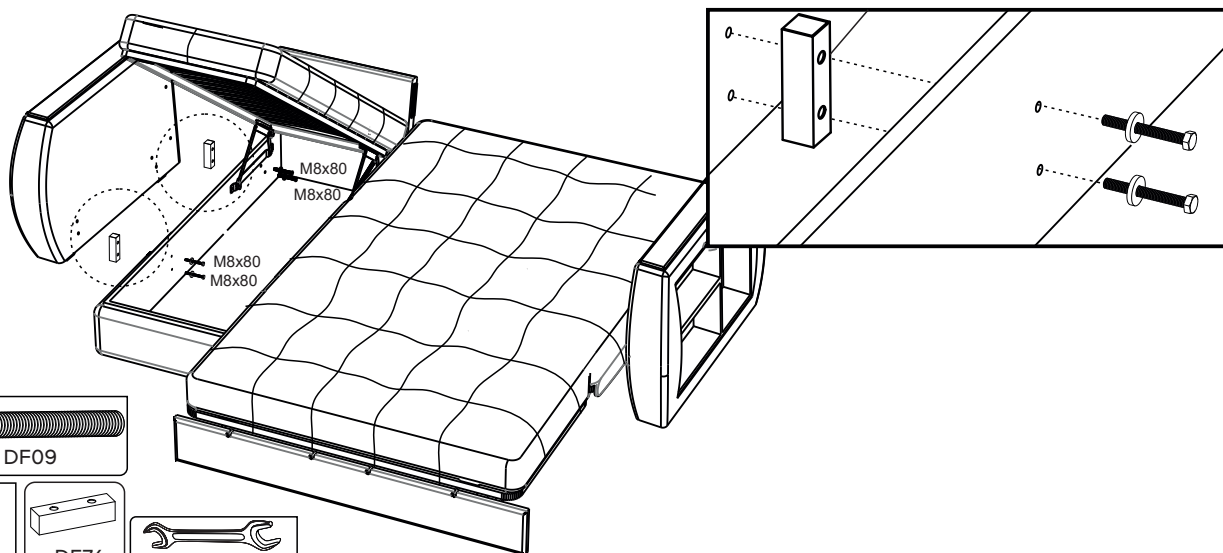

39)

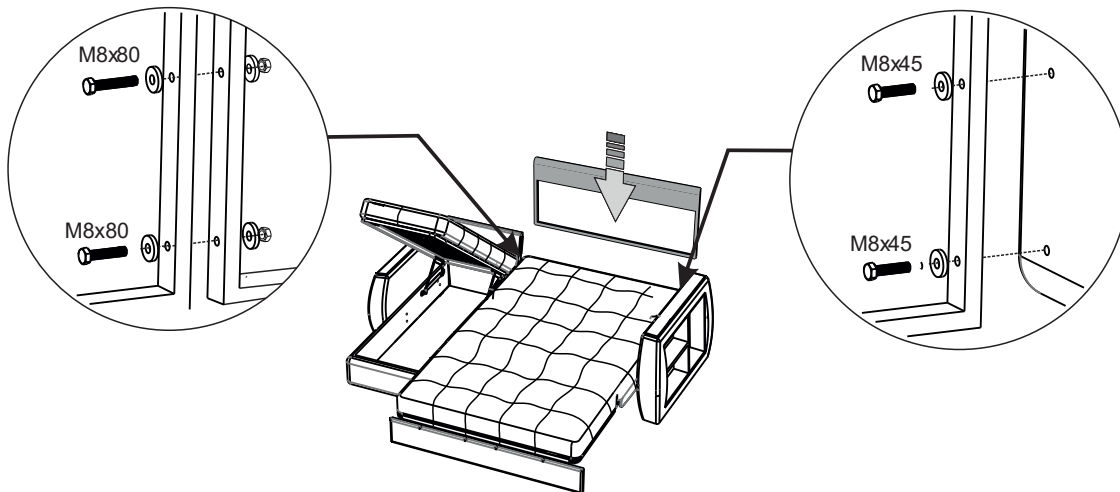

40)

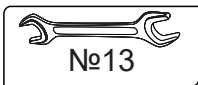
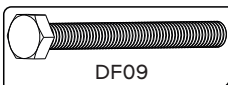
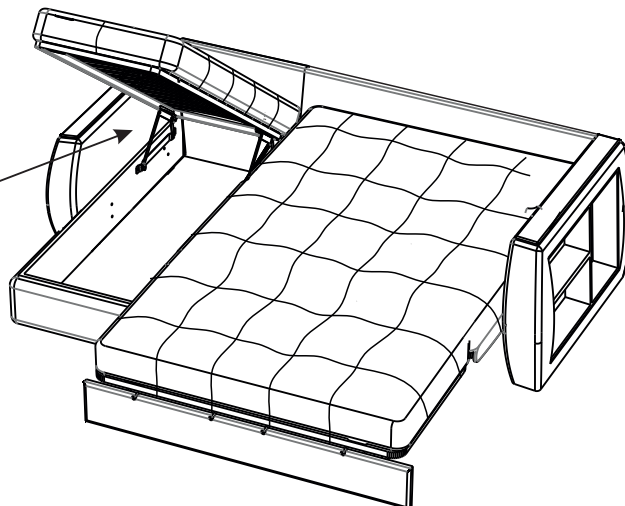
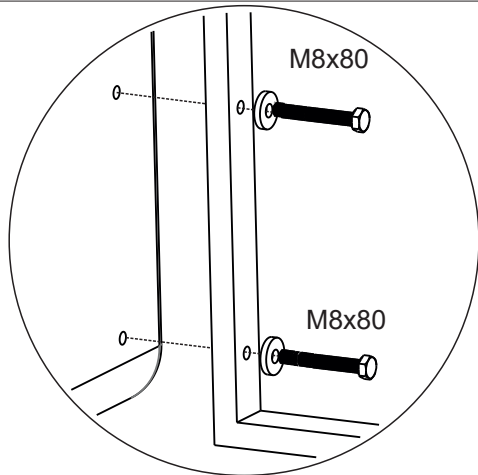

41)

1

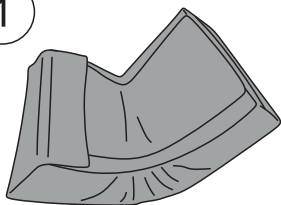

2

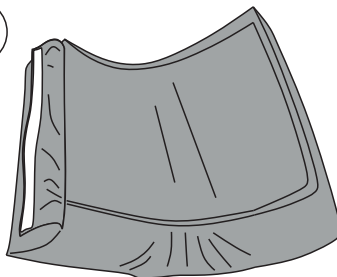

3

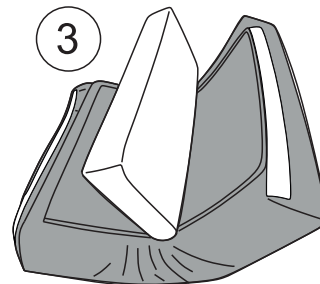

4

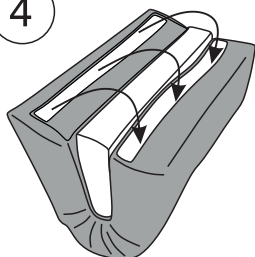

5

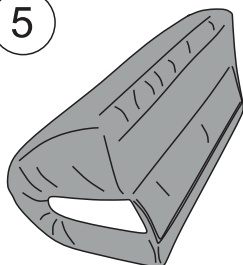

6

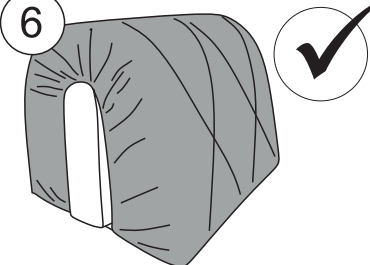

42)

b

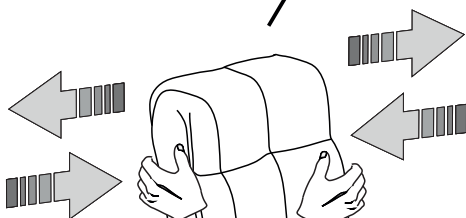

a

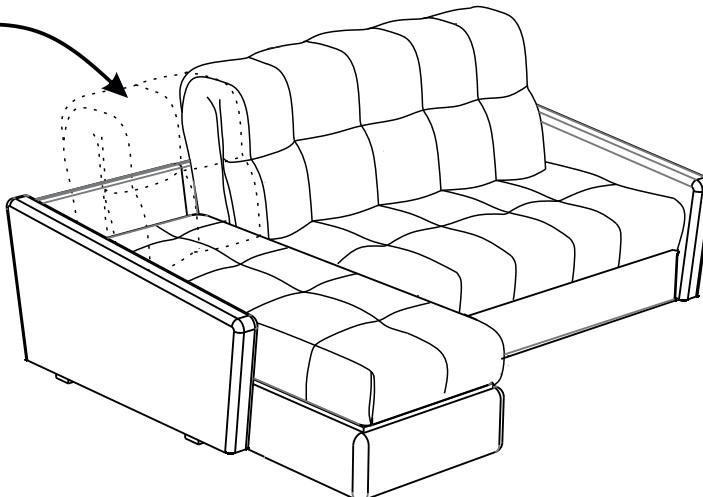

43)

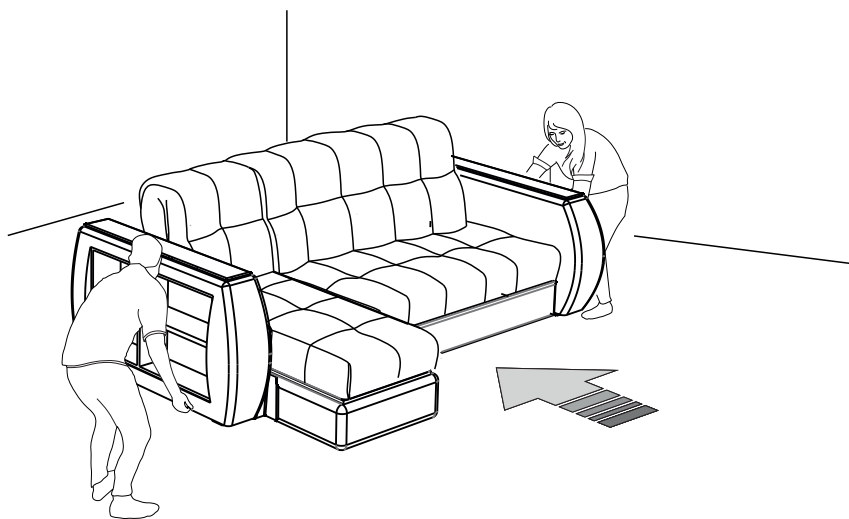

Τοποθετήστε τον καναπέ στη θέση όπου θα βρίσκεται μόνιμα

44)

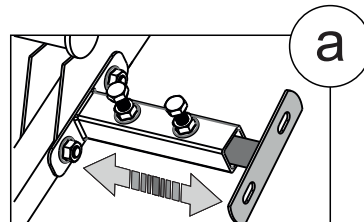
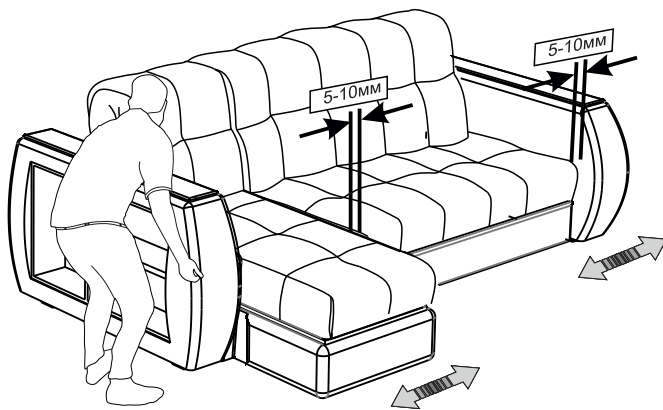

a

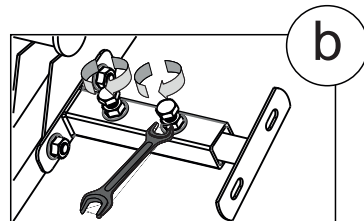

b

Σφίξτε!



45)

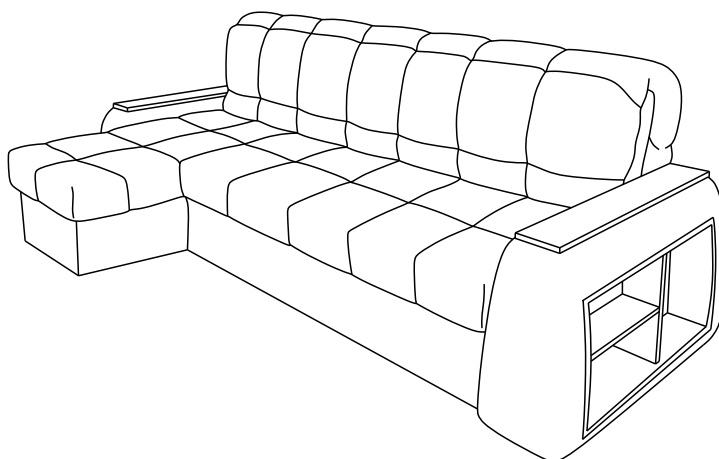



Διαδικασία μετατροπής του καναπέ

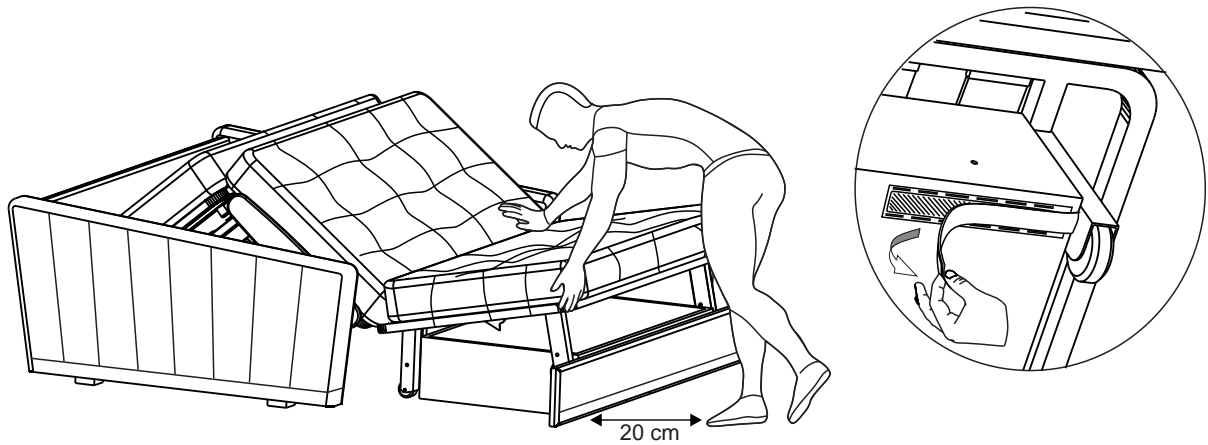
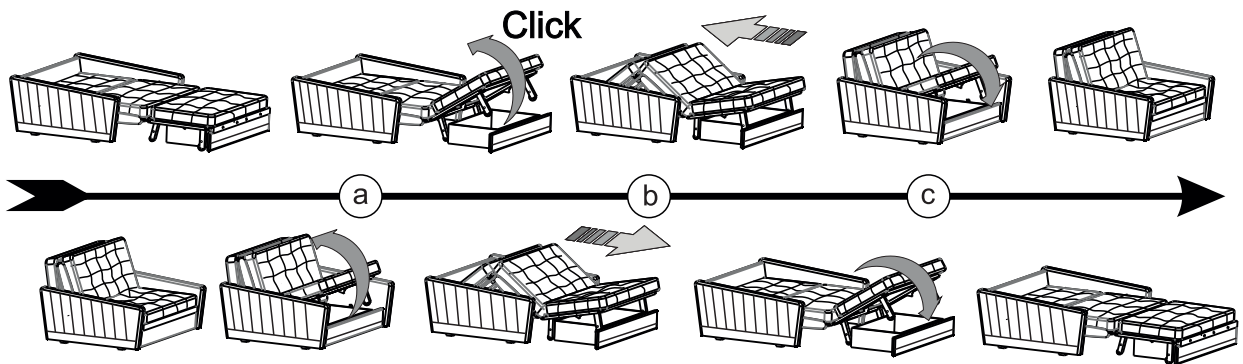

Εάν το κάθισμα του καναπέ δεν ανεβαίνει αποσυνδέστε τις αυτοκόλλητες ταινίες μεταφοράς

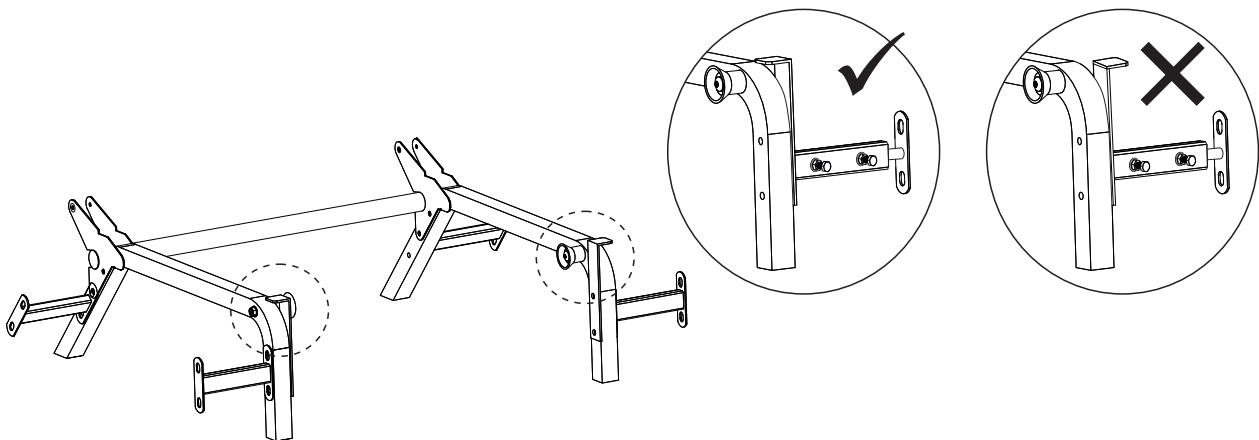

Εάν το κάθισμα του καναπέ δεν ανοίγει ελέγξτε τη θέση των στηριγμάτων στο μηχανισμό.



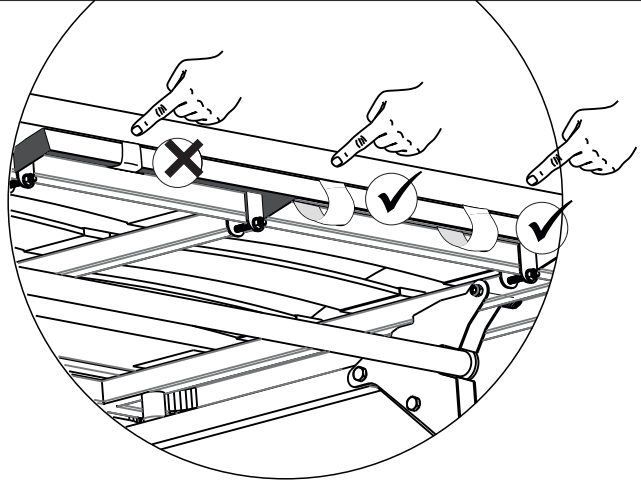
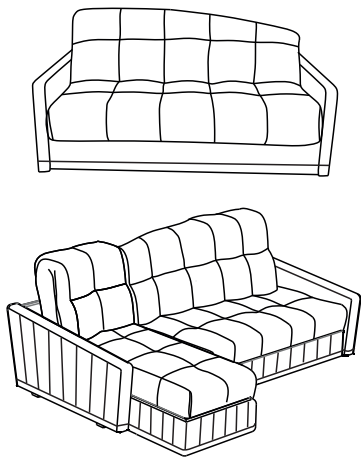

Εάν η πλάτη βρίσκεται σε λοξή θέση χαλαρώστε τις συνδετικές ταινίες στην κεφαλή

Εάν η απόσταση ανάμεσα στο στρώμα και το υποβραχιόνιο είναι μεγάλο ανεβάστε την περιοχή του καθίσματος και χαλαρώστε τις συνδετικές ταινίες

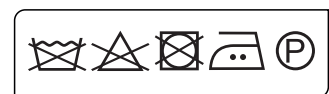
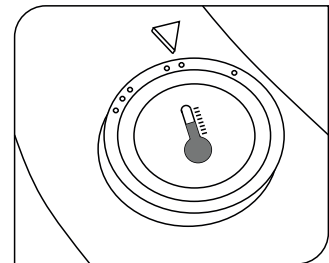
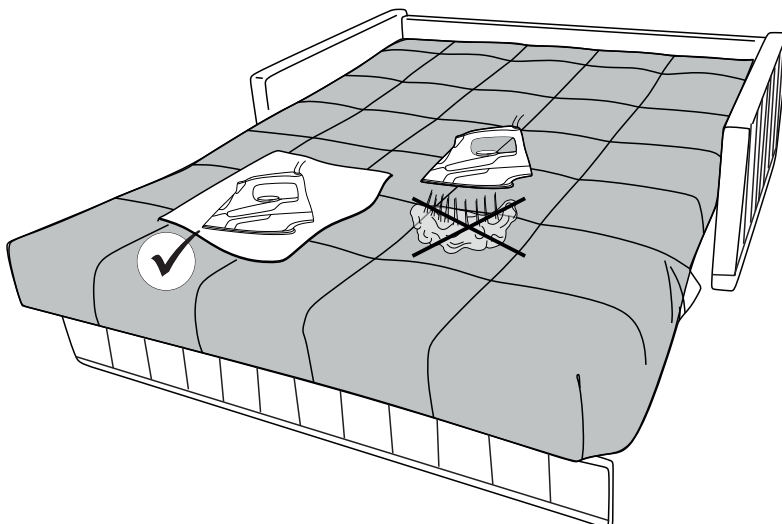
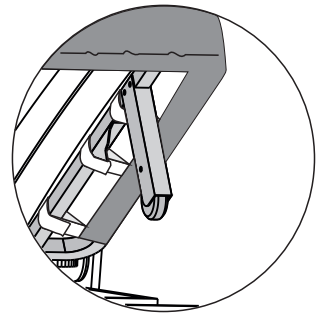
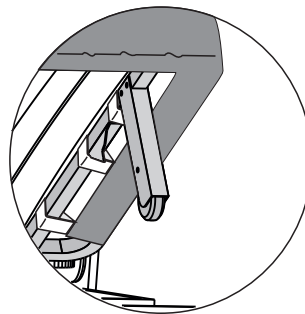
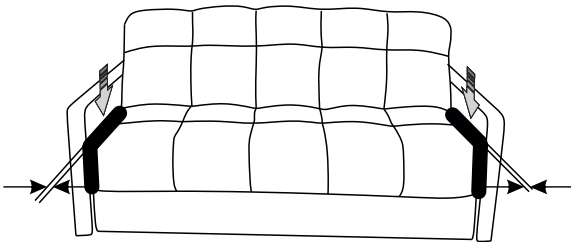
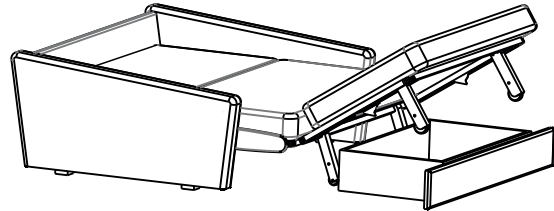

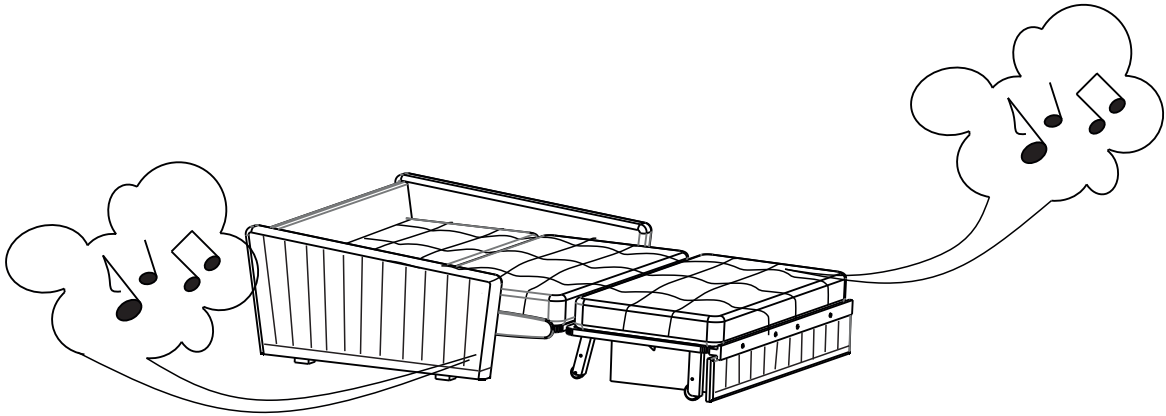

Θυμηθείτε: η χαρακτηριστική σκασίματα των μεταλλικών στοιχείων του μηχανισμού κατά τη διάρκεια του συνεχούς μετασχηματισμού είναι μια φυσιολογική κατάσταση. Στην καρδιά του καναπέ είναι μια αξιόπιστη μεταλλική δομή που σας επιτρέπει να μετατρέπετε τον καναπέ σε ένα κρεβάτι κάθε μέρα. Κατά τη διάρκεια του μετασχηματισμού και της λειτουργίας, το λιπαντικό μεταξύ διαφορετικών τμημάτων του μηχανισμού μπορεί να στεγνώσει και υπάρχει τριβή μεταλλικών στοιχείων μεταξύ τους. Προκειμένου να αποφευχθεί η εμφάνιση αυτής της τριβής και σκασίματος του μηχανισμού κατά τη διάρκεια του μετασχηματισμού ή της λειτουργίας, είναι σημαντικό να ακολουθήσετε τις συστάσεις του κατασκευαστή. Όταν ο μηχανισμός τρεμοπαίζει, τα στοιχεία τριβής πρέπει να λιπαίνονται

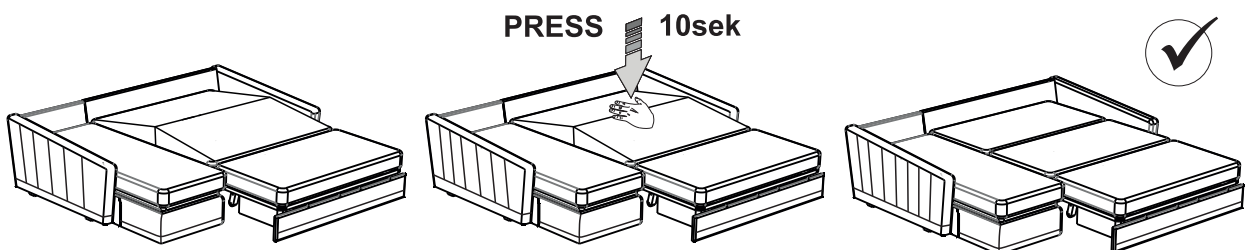
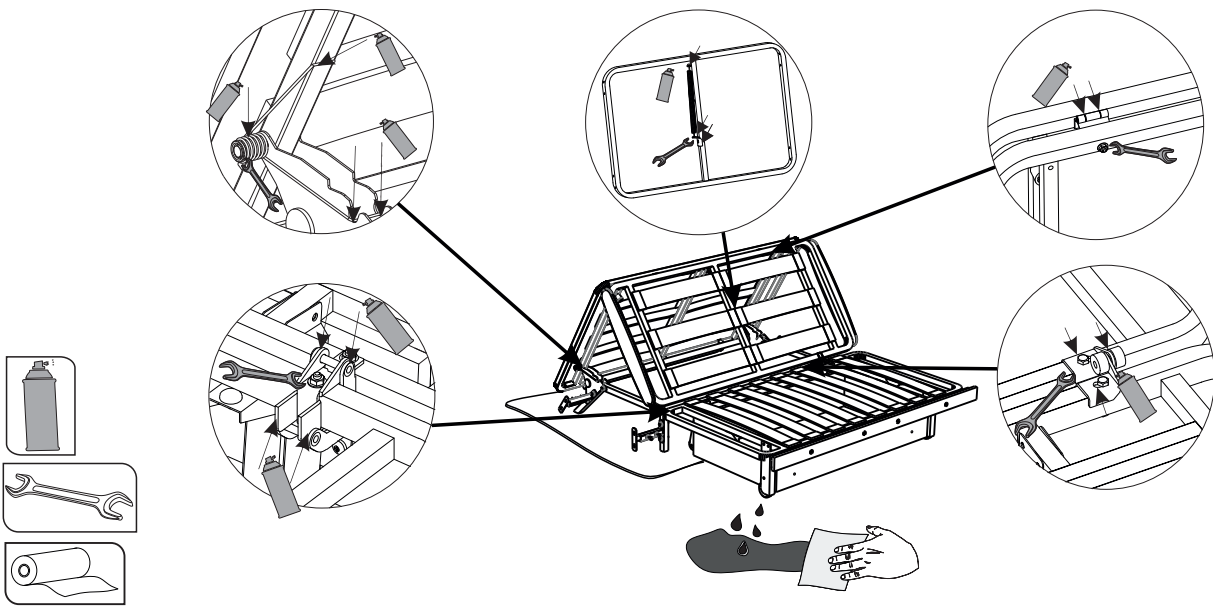

πατήστε 10  
δευτερόλεπτα

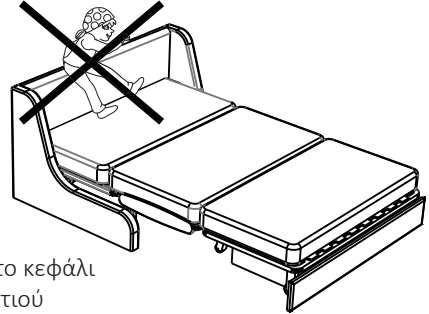
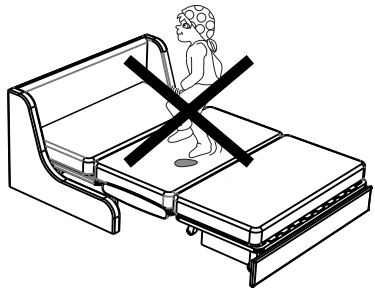
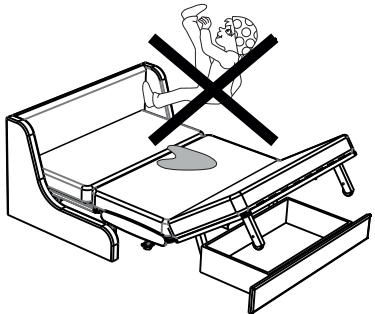
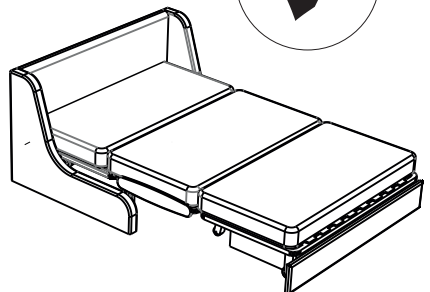
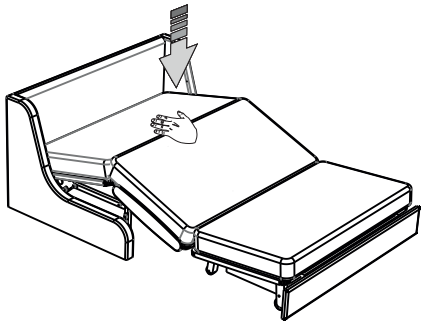
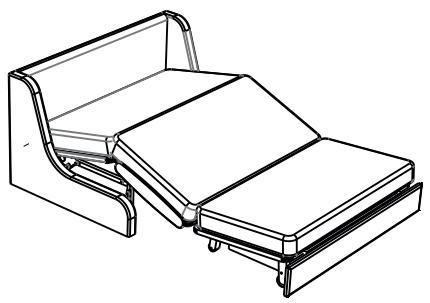

μην κάθεται στο κεφάλι  
του κρεβατιού

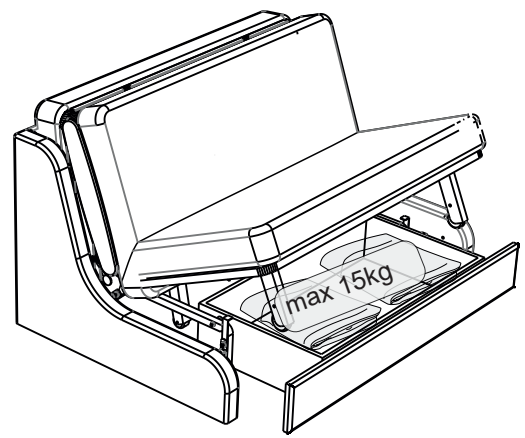





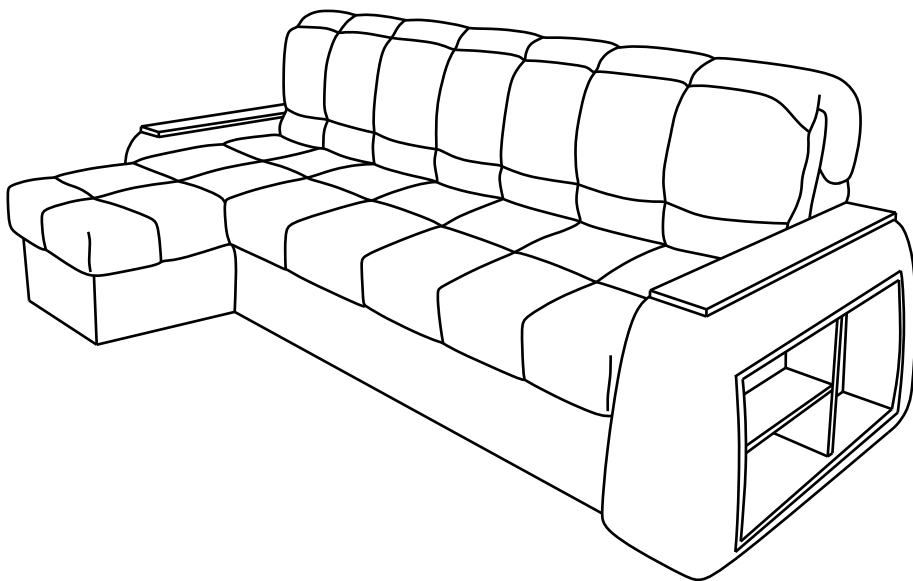
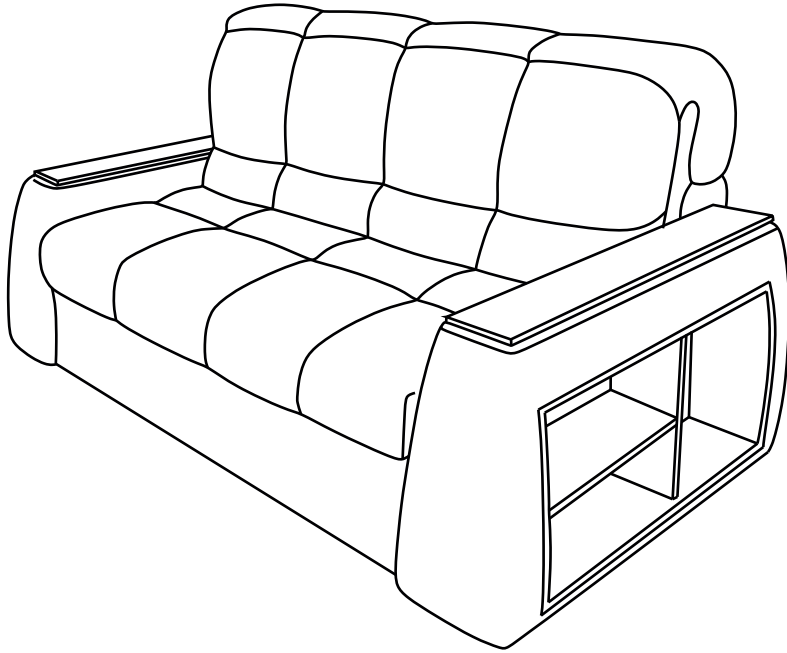

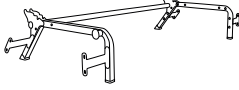

# SUNSET NOVA

ET



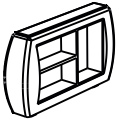
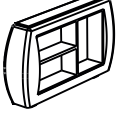

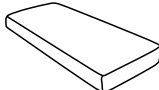

Sleep.8

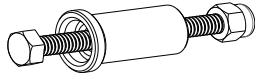
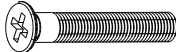

## Komplekti sisu

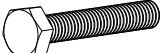
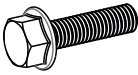
Pakend	Detail	Artikkel	Nimetus	Arv
№ 1		D01	Transformatsiooni mehhanism	1
		D26	Mehhanismi tugi	1
		D04	Seljatugi	1
		D05	Laud	1
		D07	Tepitud istmekate	1
			Liitmike pakk	1
			Toode pass, kokkupaneku juhend, kanga näidis	1
№ 2		D06	Käetugi	1
№ 3		D06	Käetugi	1
№ 4 nurgadiivani lisa		D14	Nurgaosa	1
		D11	Nurga padi	1
		D08	Nurga kate, kate kanga näidis	1
			Liitmike pakk	1
			Toode pass, kokkupaneku juhend, kanga näidis	1
Tarnitakse eraldi		D20	Madrats	1
		D21	Nurga madrats	1

## Diivani liitmike nimekiri

Pakend	Detail	Artikkel	Nimetus	Arv
Liitmike pakk		DF02 DF15 DF16	Polt M6x65 Plastist varrukas Mutter M6 (isekinnitav)	2
		DF11	Kruvi-potai M6x30	3
		DF31	Konksudega vedru	2
		DF06	Polt M8x45	4
		DF56	Polt M8x30	8
		DF42	Seib M8	4

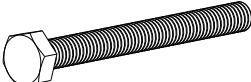
## Nurgaosa liitmike nimekiri

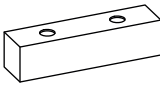
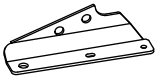
Pakend	Detail	Artikkel	Nimetus	Arv
Liitmike pakk		DF30	Nurga vedru (ainult väiksel nurgal)	2
		DF09	Polt M8x80	10
		DF19	Mutter M8	6
		DF42	Seib M8	14
		DF74	Lisaplaat nurgaosale	4
		DF75	Mehhanismi peatus	2

### Enne kokkupanekut:

- Kontrollige pakendi osade välimust ja terviklikkust!** Nende kahjustamise nõudeid aktsepteeritakse ainult toodetel, millel pole montaažijälgi.
- Salvestage pakend ja juhised kuni kokkupaneku lõppuni!** Kui kokkupaneku käigus tuvastatakse defekti ja toote ebakomplektsust, on vaja pakendit säilitada kuni kaubandusettevõtte esindaja teie juurde jõudmiseni.
- Kontrollige osade ja liitmike arvu nimekirja järgi.** Tootja jätab endale õiguse teha tootes konstruktiivseid muudatusi, asendada liitmikud ja riistvara sarnaste toodetega, mis ei kahjusta toote välimust ega mõjuta toote funktsionaalseid omadusi. Kui see on puudulik või katki, tähistage ringiga puuduva osa number ja teatage poodi selle asendamiseks.
- Järgige selles juhendis antud kokkupaneku järjekorda!** Kui montaaži- ja kasutusjuhiseid ei järgita, eemaldatakse tootjalt garantiikohustused.
- Diivanvoodi/tugitoolvoodi paigaldamiseks valige tasane põrandapind!** Põranda kumerusel on võimalikud kõrvalekalded diivanvoodi/tugitoolvoodi muundamise mehhanismi töös, toote kuju moonutused. Vaiba olemasolu on ebasoovitav, kuna see raskendab ümberkujundamist.
- Pange diivanvoodi/tugitoolivoodi kokku kahekesi.** Liigutage kõiki osi ettevaatlikult, ilma tõblemiseta, paigaldage ühtlaselt, vältige nende kukkumist ja löömist!
- Liigutage mööblit ja selle osi ainult kergelt tõstes.** See välistab deformatsiooni ja purunemist.
- Määrige monteerimise ajal kindlasti tõstemehhanism vastavalt juhistele!** See väldib enneaegse kriikumise ilmumist. Korrake määrimist, pingutage nähtavalt lahtised poldid ja mutrid vähemalt kord kuue kuu jooksul.

### Kokkupanemiseks vajate

	Ristpeaga kruvikeeraja
	Lahtise otsaga mutrivõti №13 x 1 Lahtise otsaga mutrivõti №10 x 2
	Paberrätik
	Silikoonepihustusmääre
	Käärid
	Mõõdulint



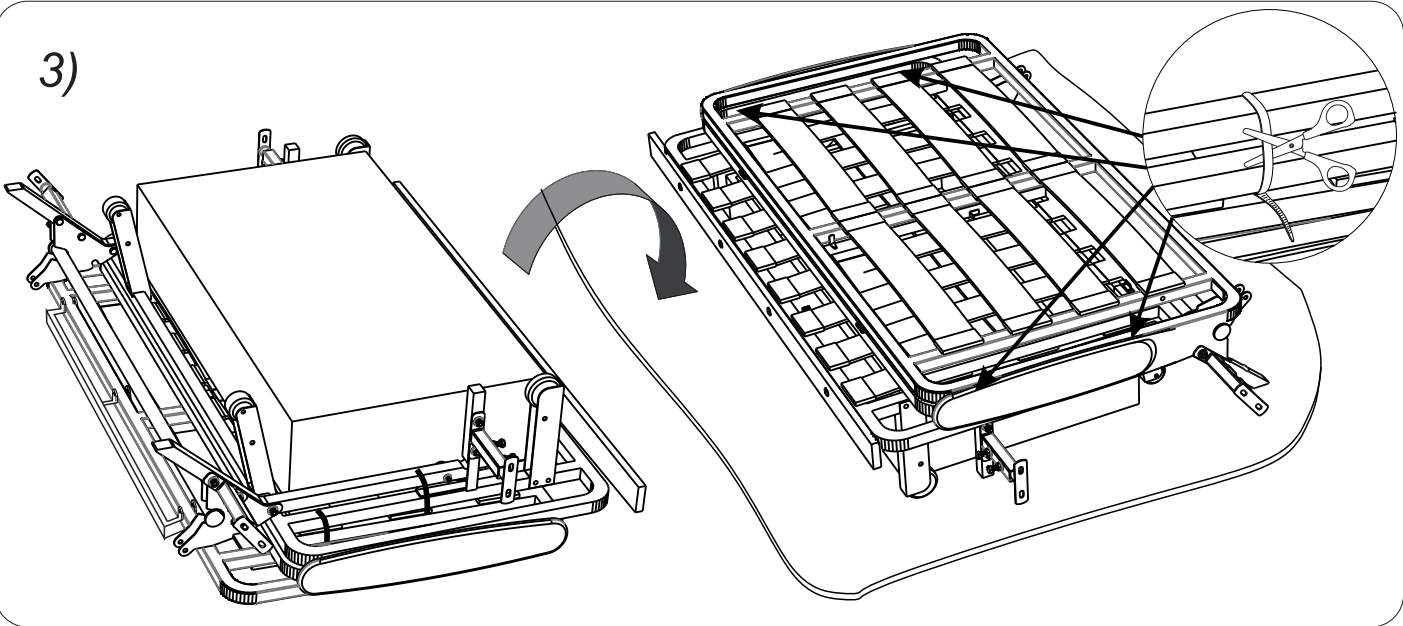
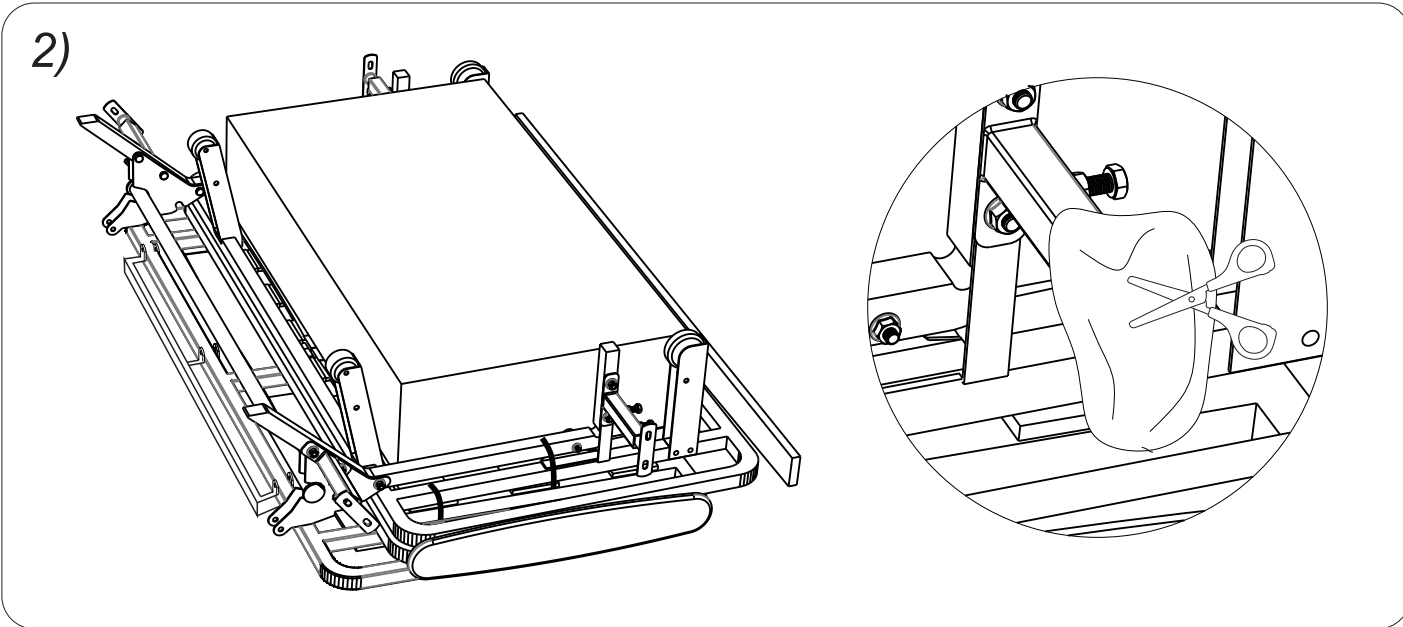
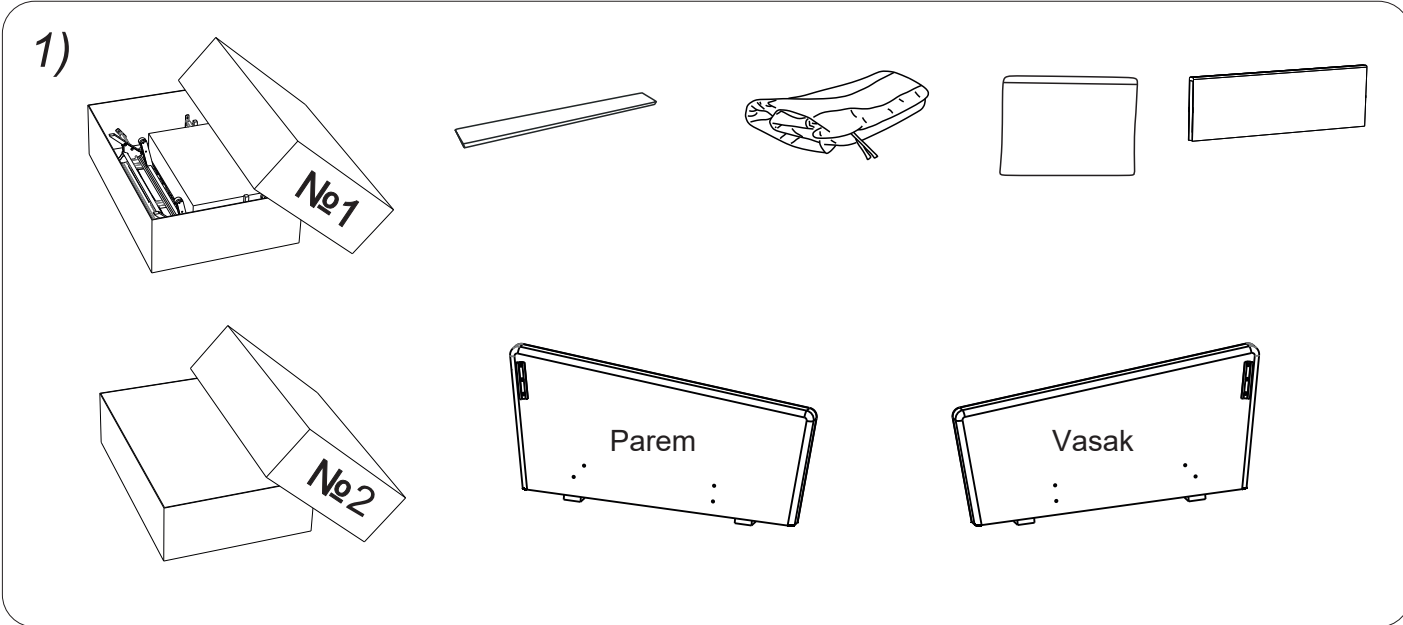

4)

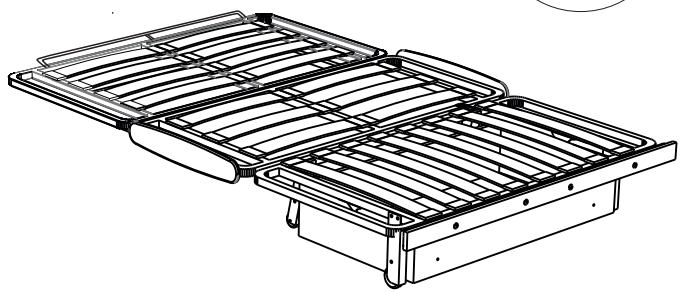
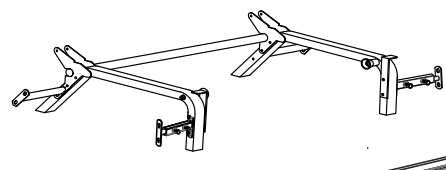
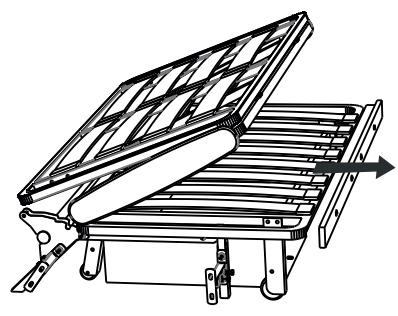

Eemaldage raam alusest

5)

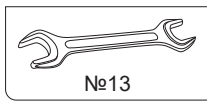
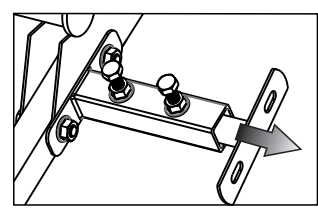
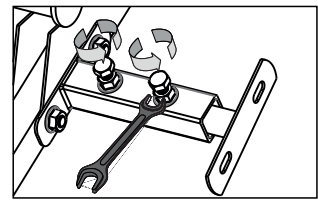

№13

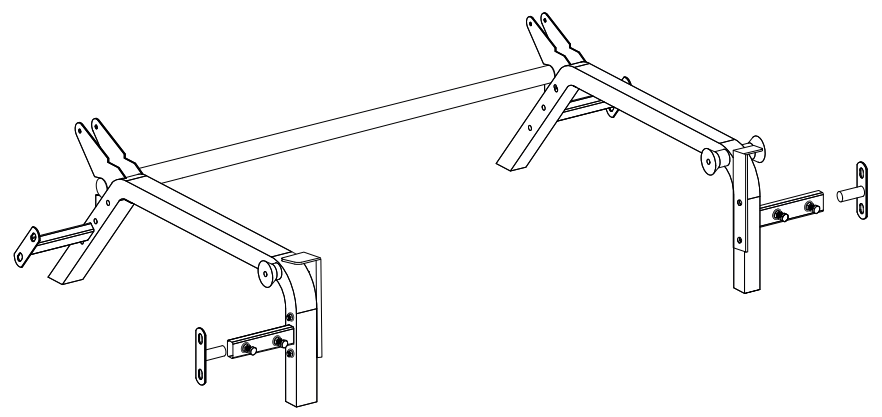

6)

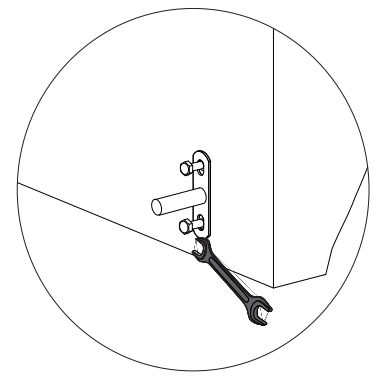
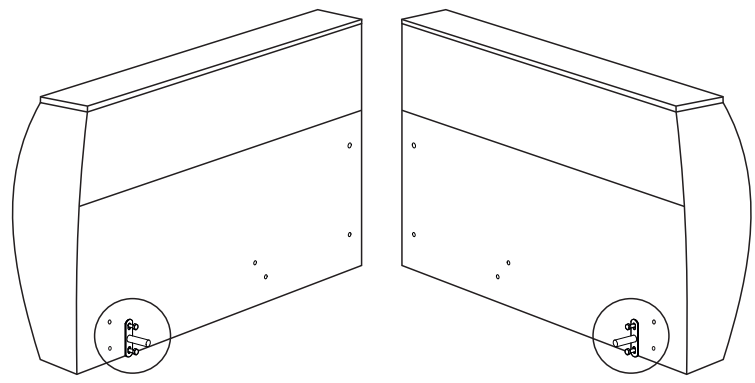

DF56

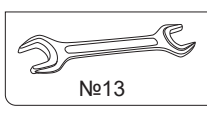

№13

Nurgadiivani kokkupanemisel paigaldage klambrid ühele kätetoele (nurgaosa vastaspoolelt)

7)

Ärge pingutage klambrite polte

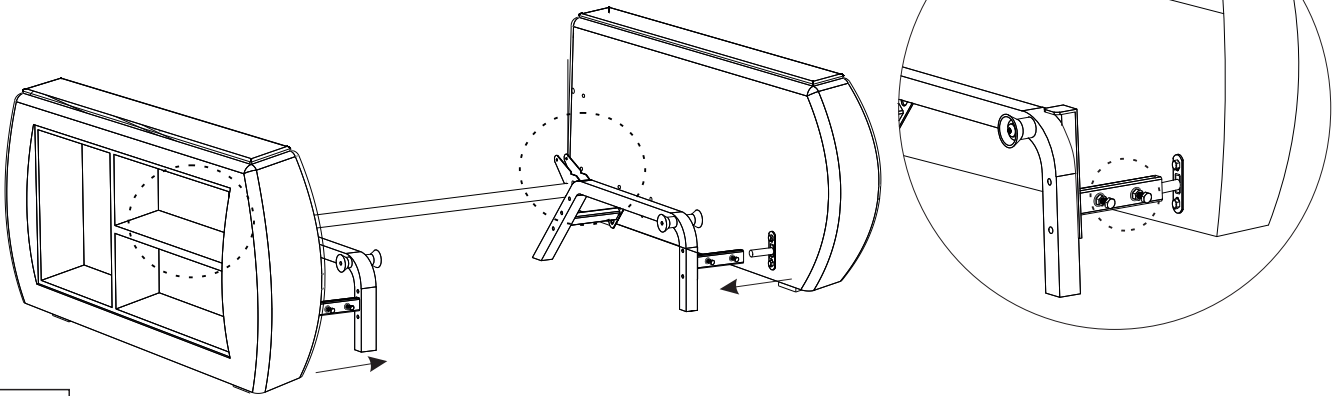

Kruvige tagumised klambrid külge.  
Ärge pingutage esiklambrite polte.

8)

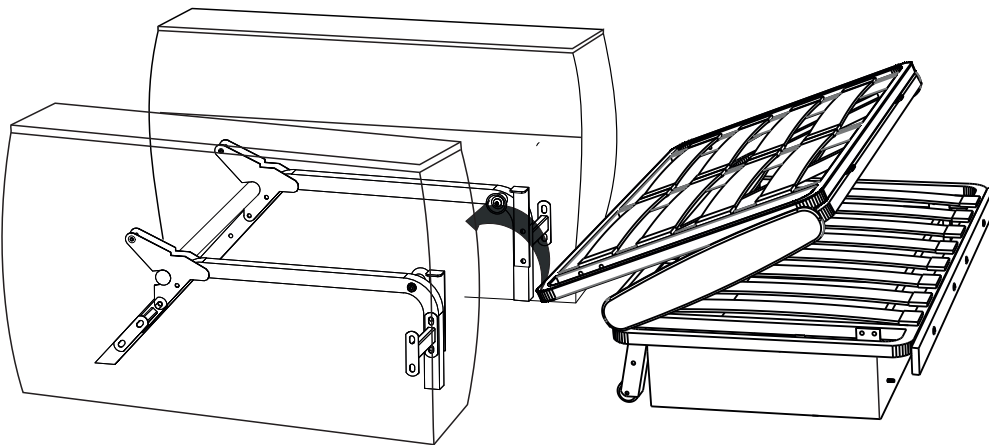

x2

Ärge pingutage jõuga

9)

x2

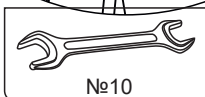
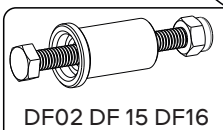
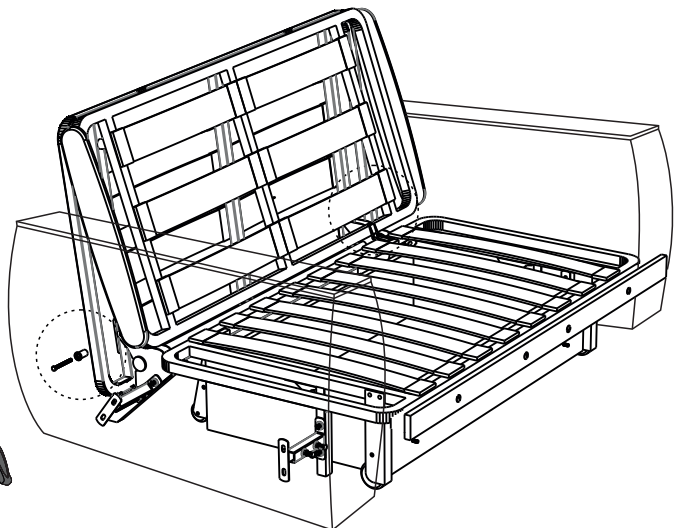
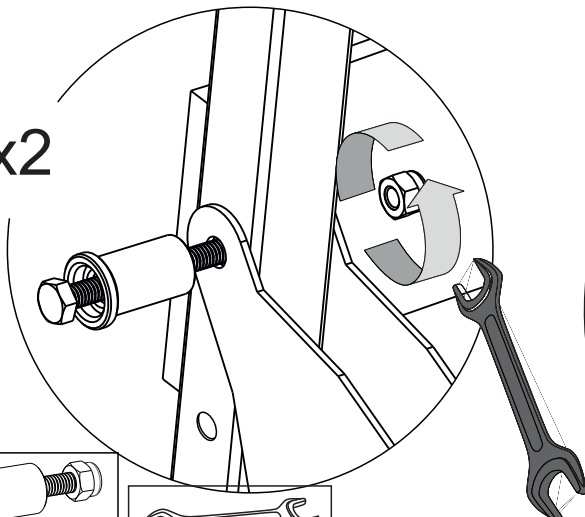

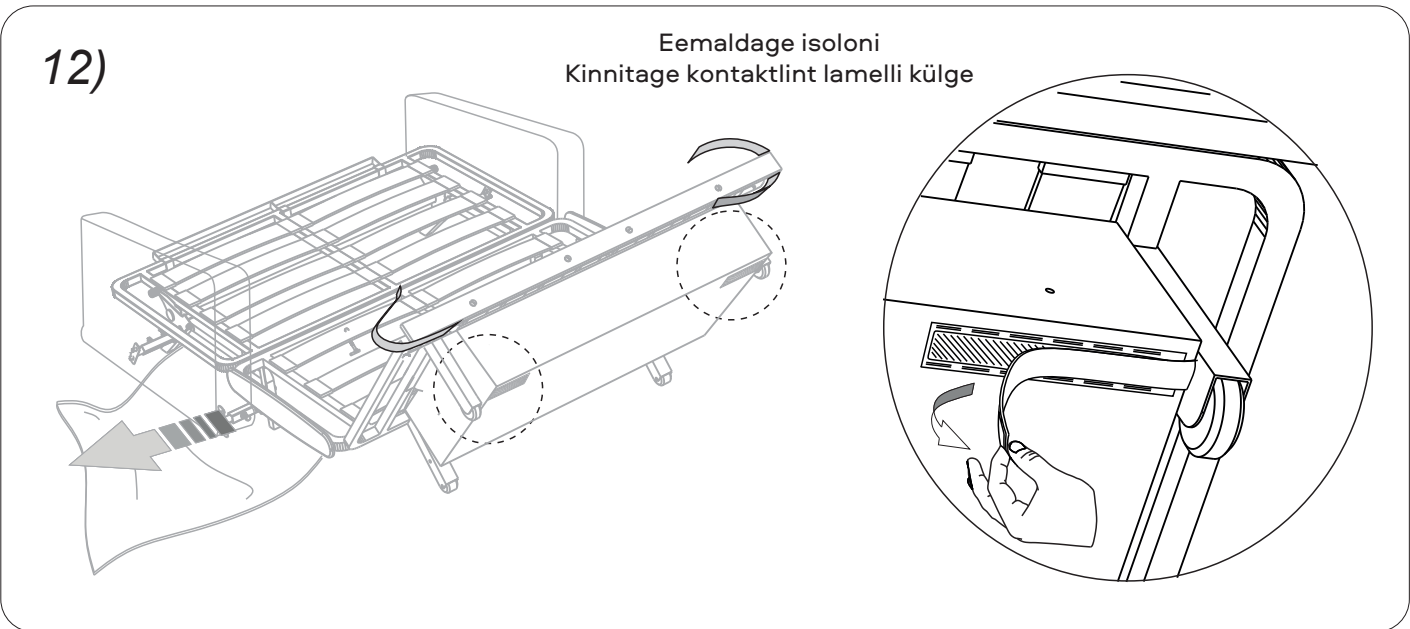
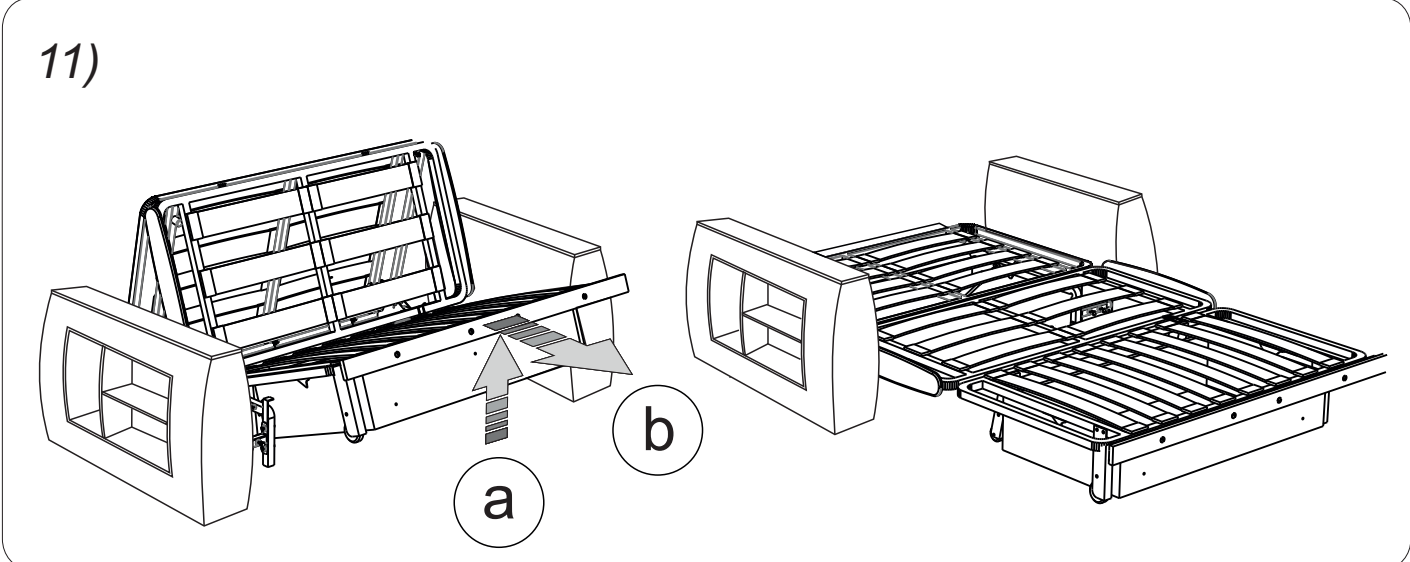
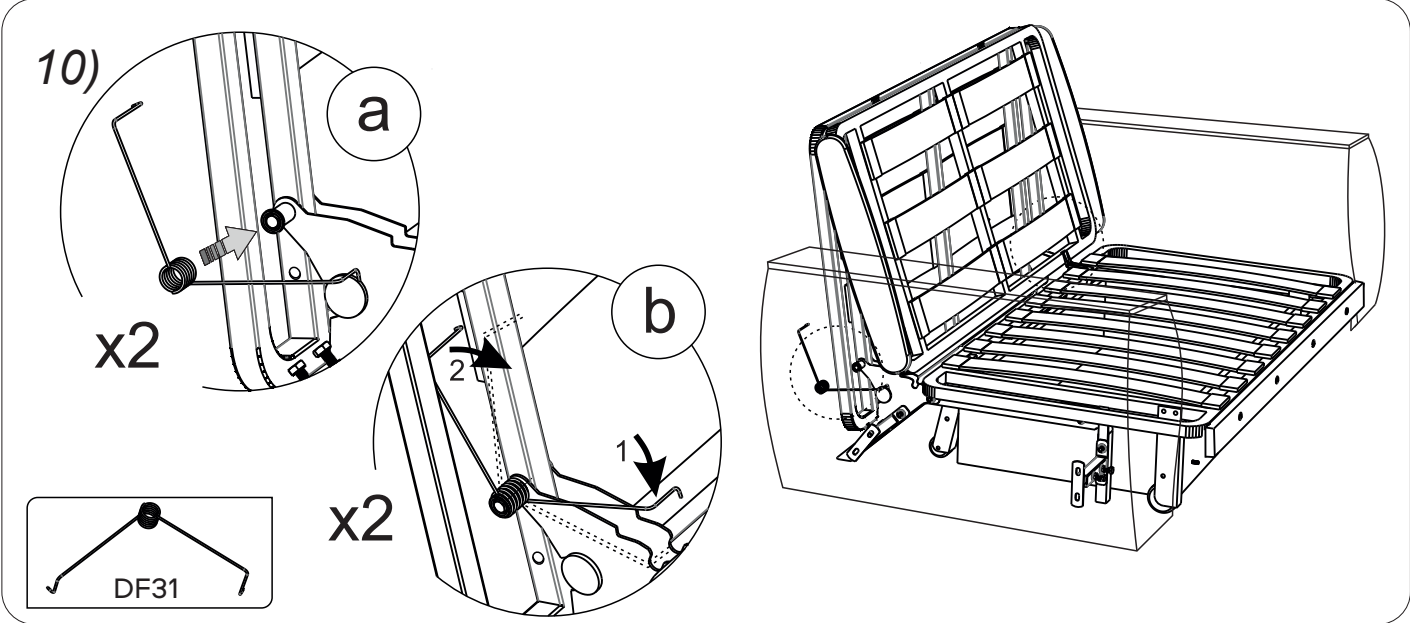

13)

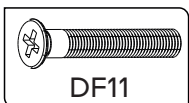
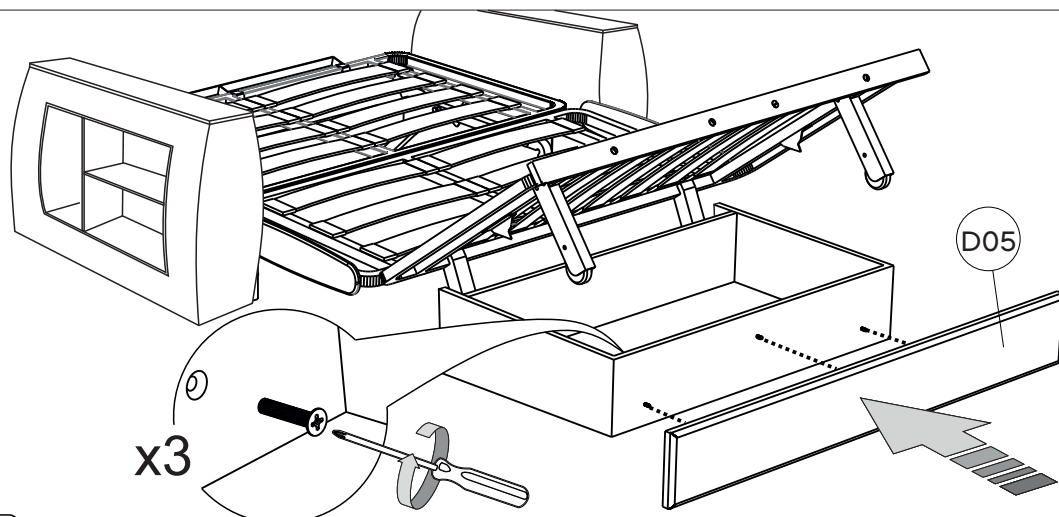

Laua alumist poolt näitab klambririba

14)

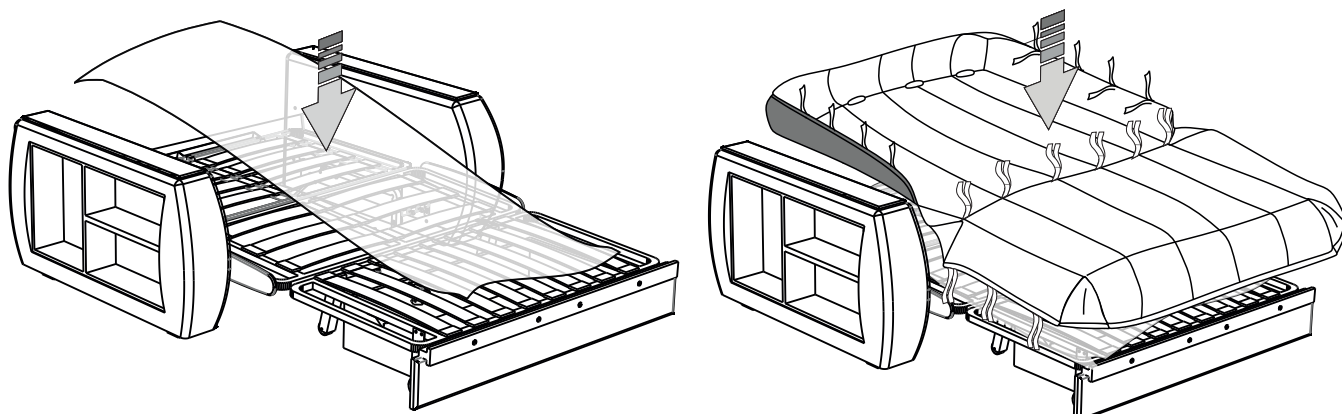

Asetage kile diivani pakendist mehhanismile, et kaitsta katet määrimise eest

15)

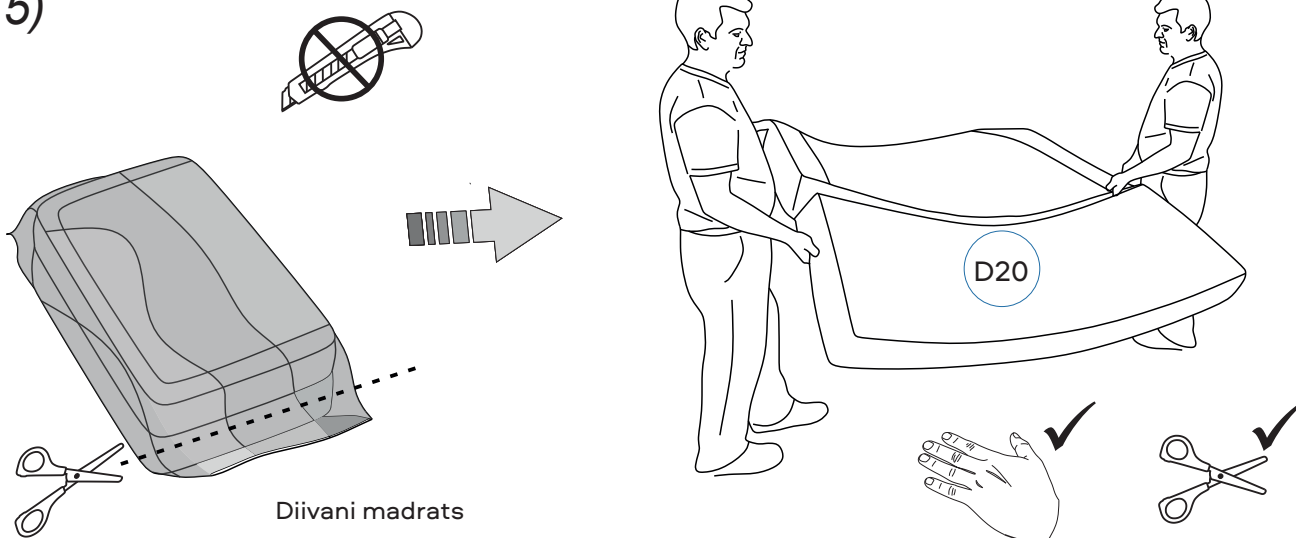

Diivani madrats



16)

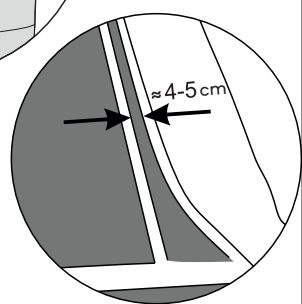
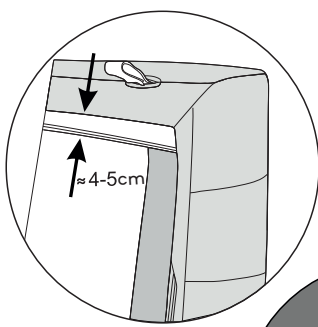
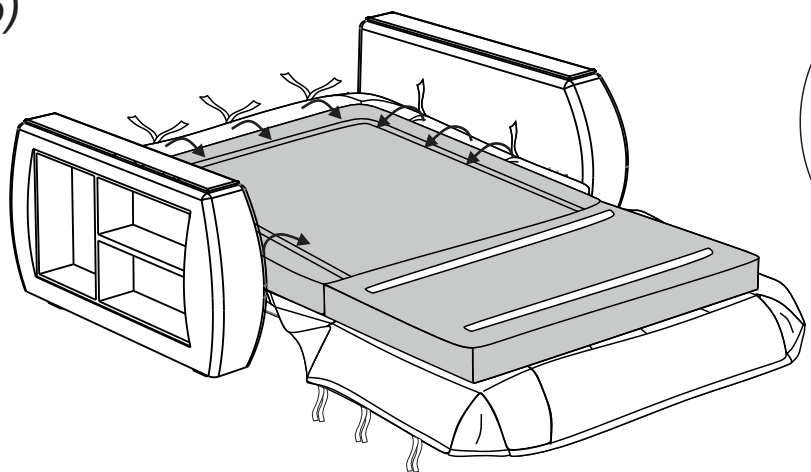

Joondage madrasi ja katte õmbelused ja nurgad. Asetage pea otsas kontaktlindid katte aukudesse.

17)

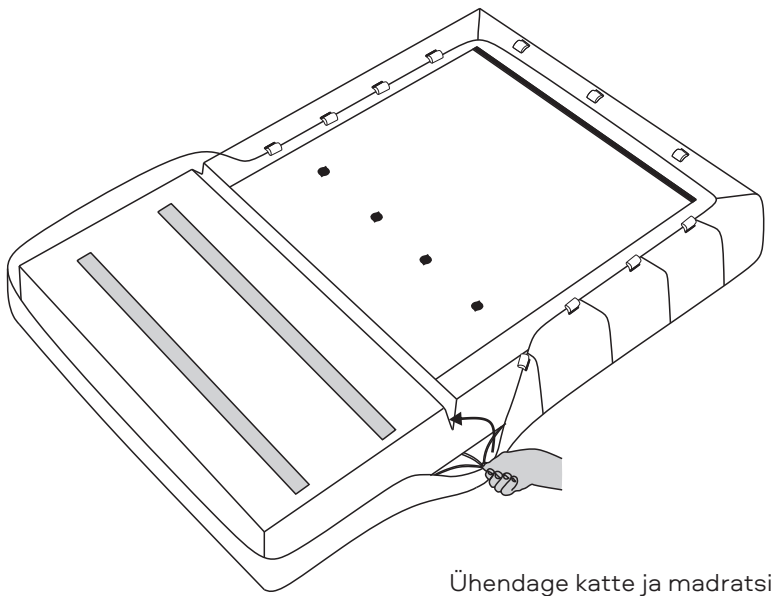

Ühendage katte ja madrasi õmbelus

18)

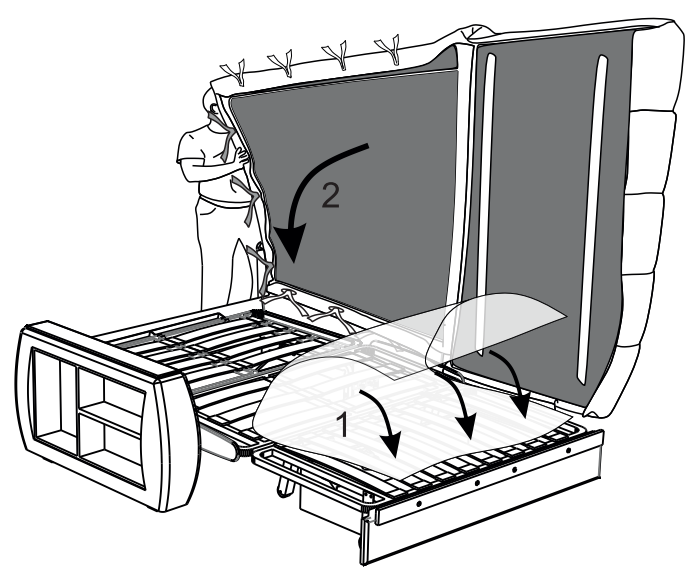

19)

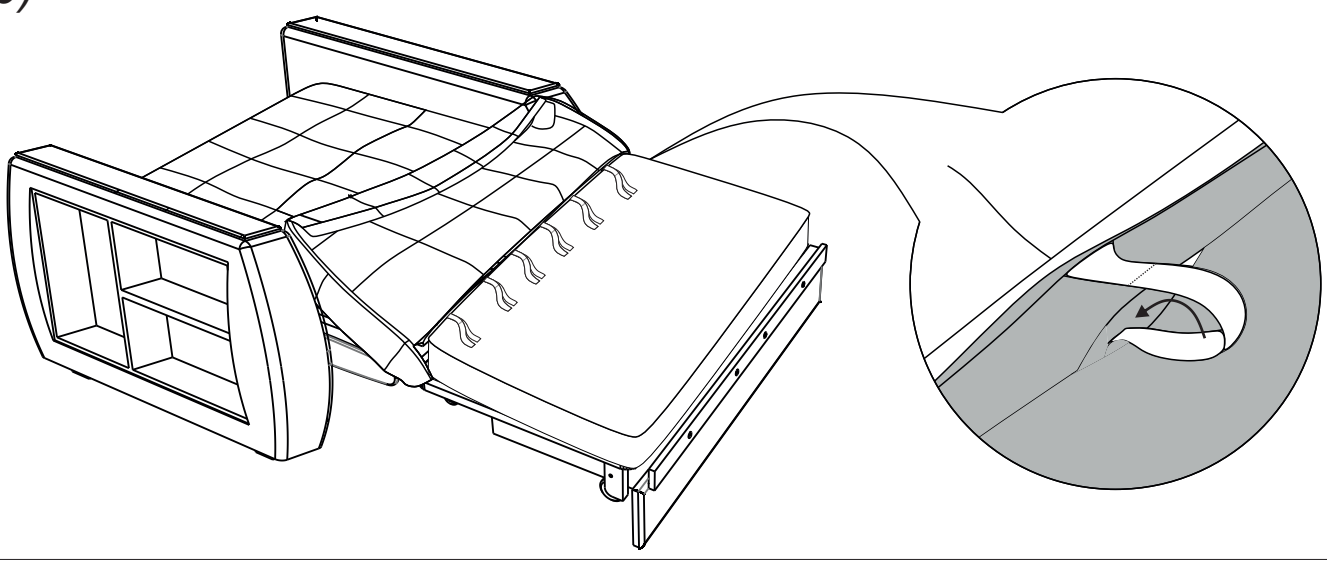

20)

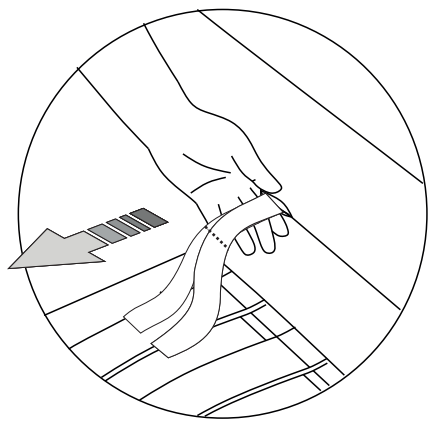
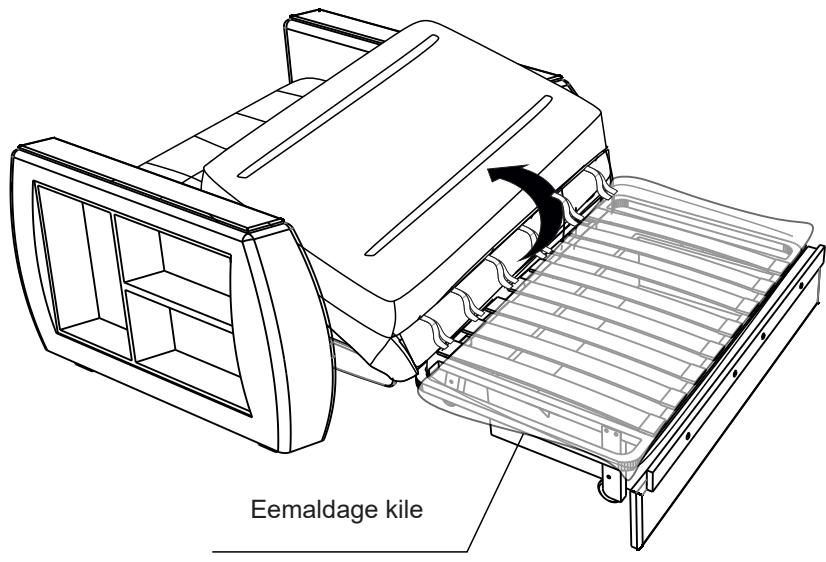

Eemaldage kile

21)

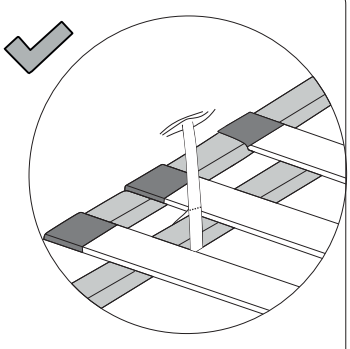
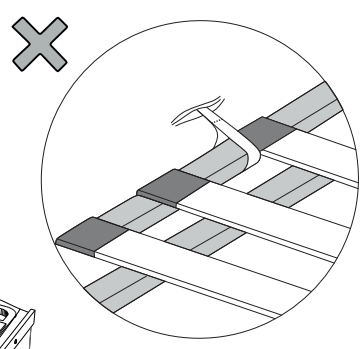
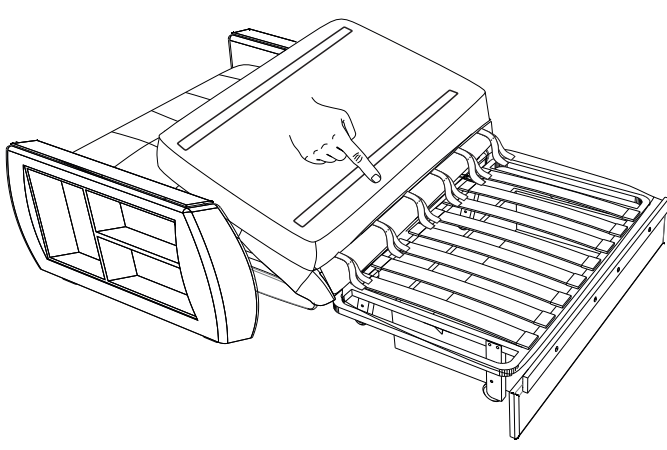

Haakige kontaktlindid, tõmmates tihedalt kinnitusjooneni.



22)

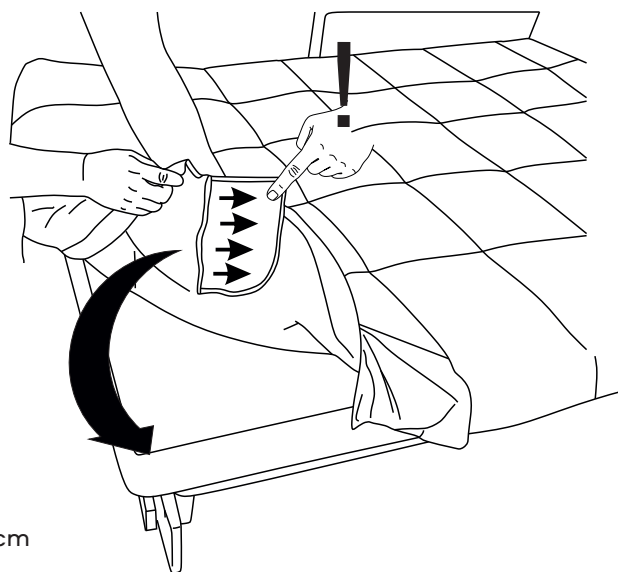
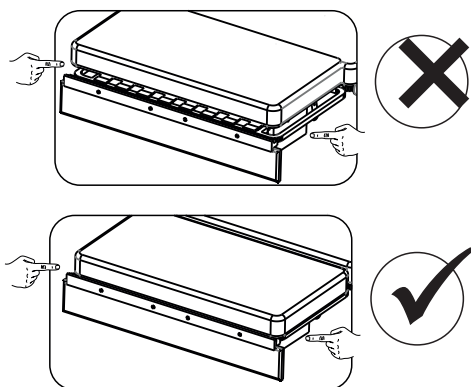

Madrats peaks liistu servast välja ulatuma mitte rohkem kui 1 cm

23)

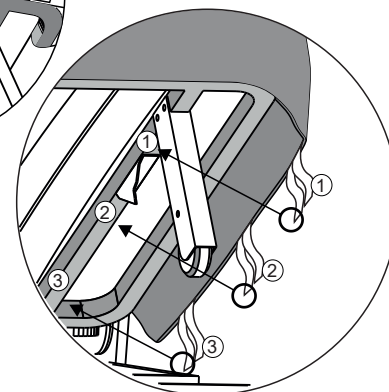
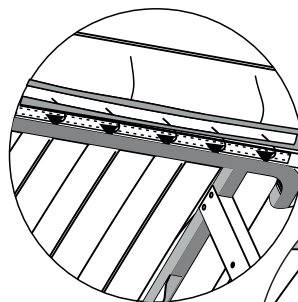
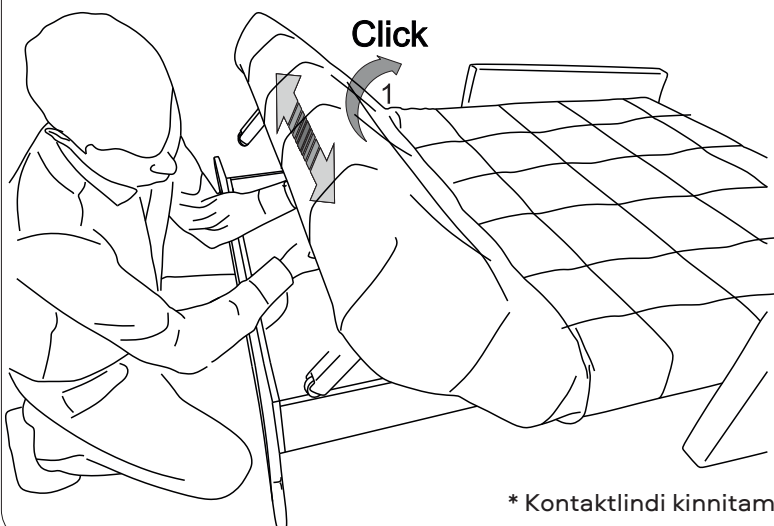

\* Kontaktlinde kinnitamine täisringig

24)

Koguge liigne kate madrasi voldiku kohale, et hõlbustada ümberkujundamist

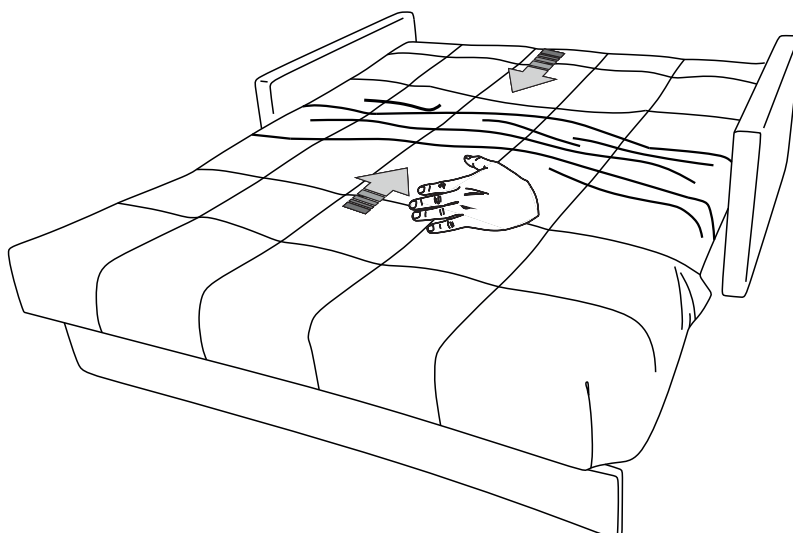

25)

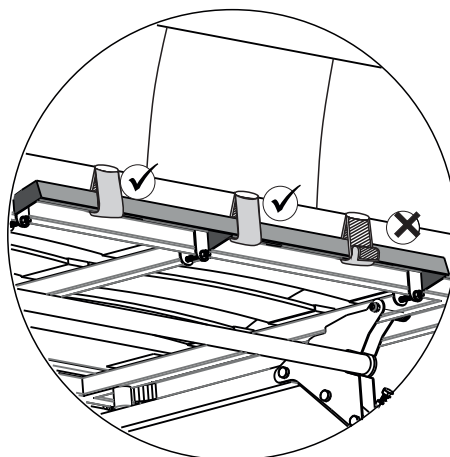
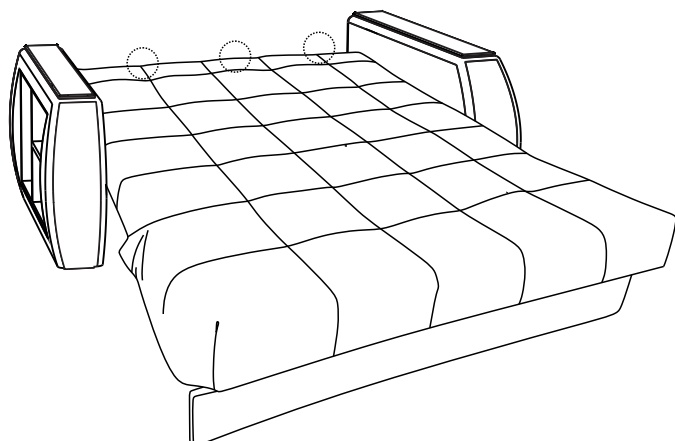

26)

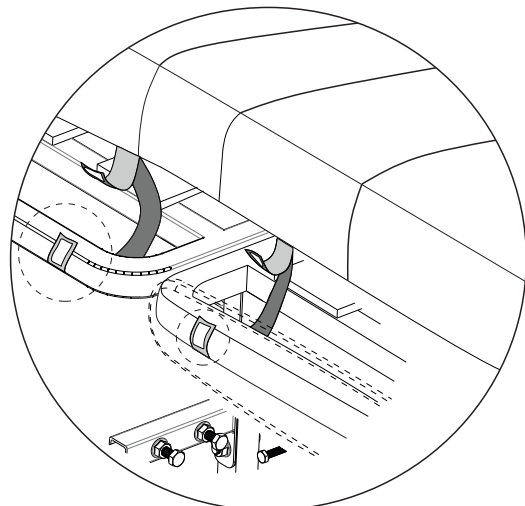
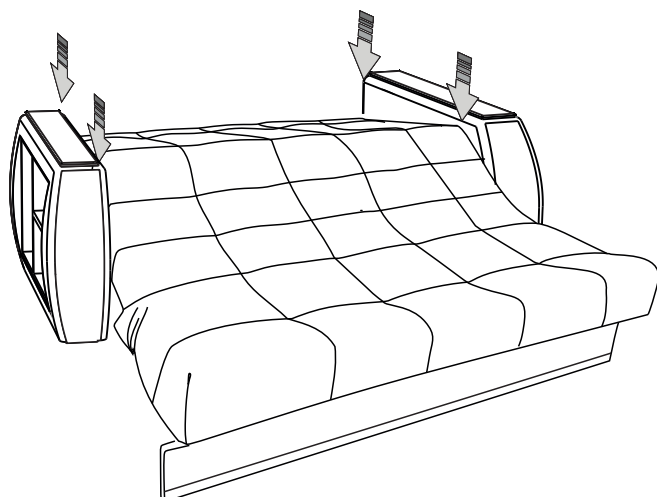

Viige diivan pooleli lahtisesse asendisse.  
Kinnitamisel tuleks kontaktlindid pingutada nii palju kui võimalik.

27)

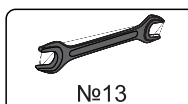
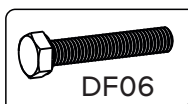
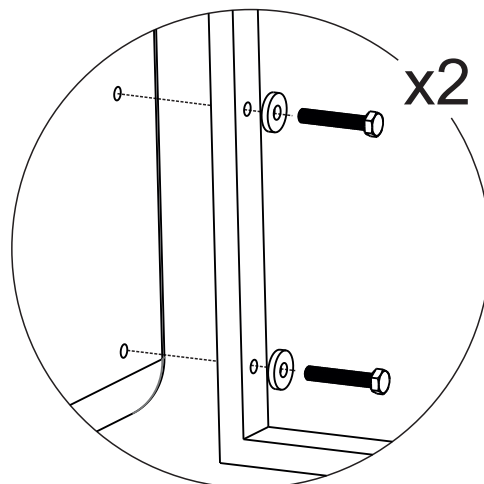
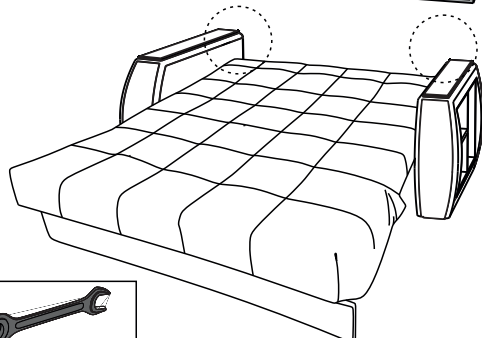
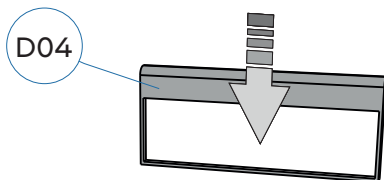

Nurga olemasolul alustage nurgadiivani kokkupaneku

28)

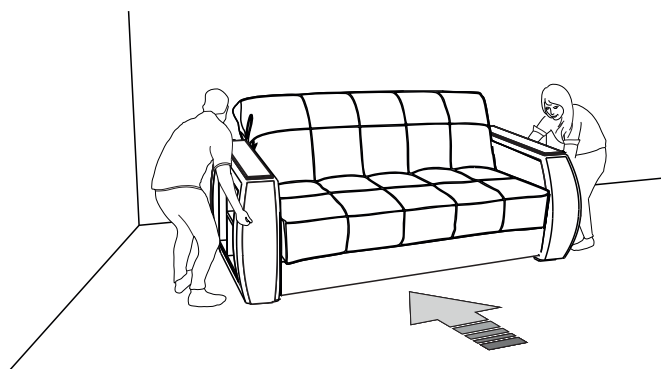

Paigaldage diivanit alaliseks kasutamiseks

29)

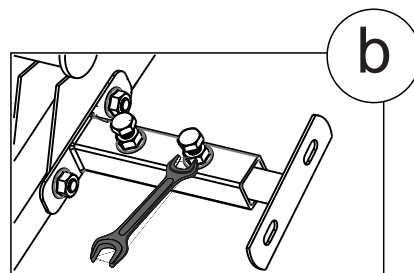
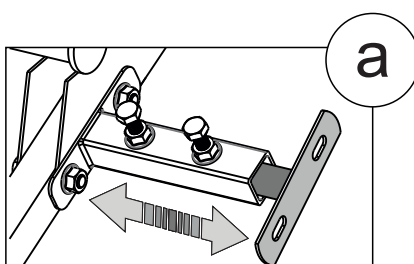
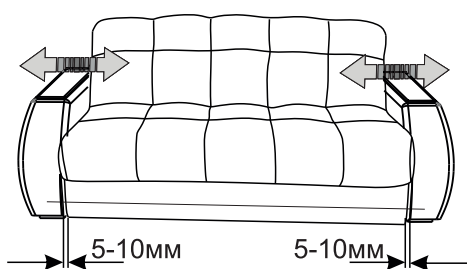

Kinnitage!

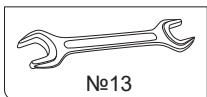

30)

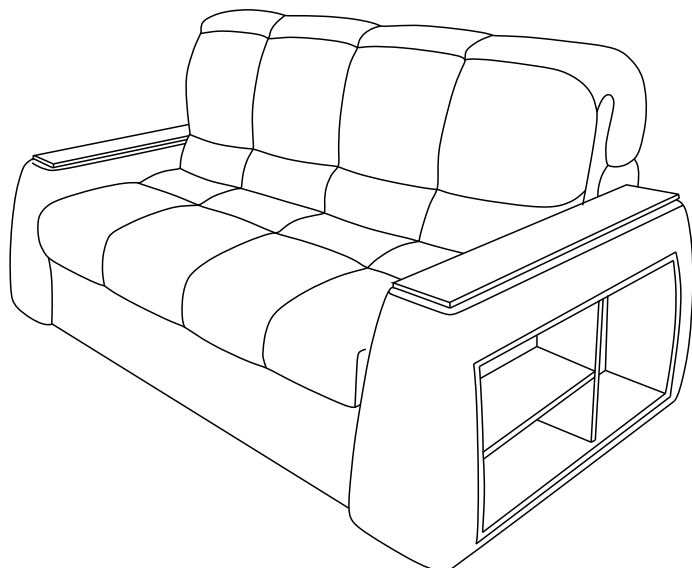

Nurgadiivani kokkupanek

31)

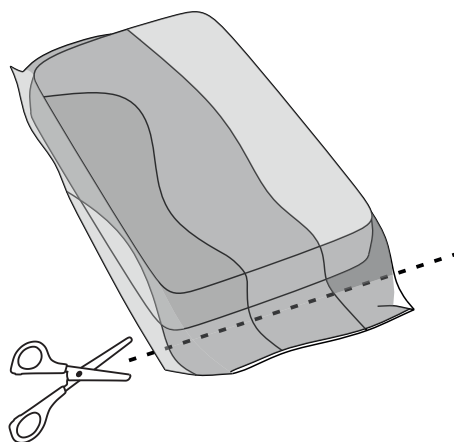
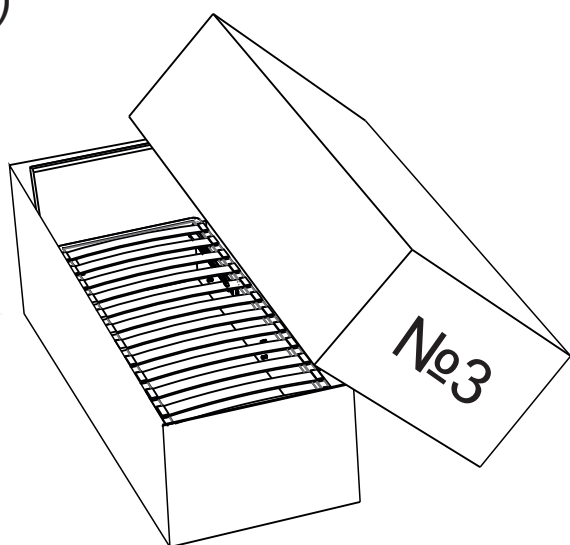

32

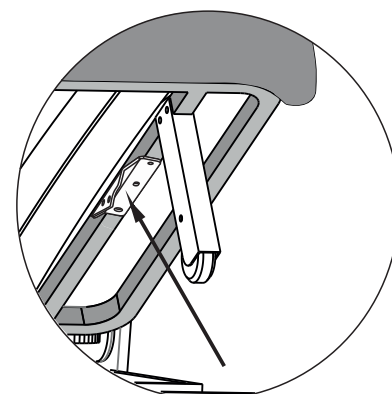
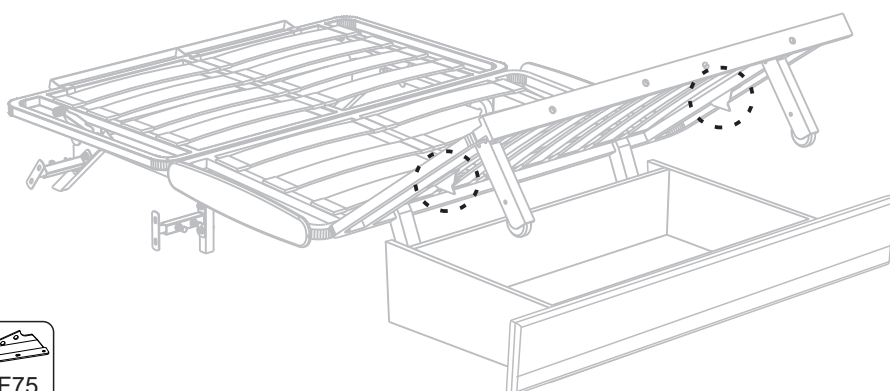

33)

Vedrud paigaldatakse ainult väikestele nurgaosale

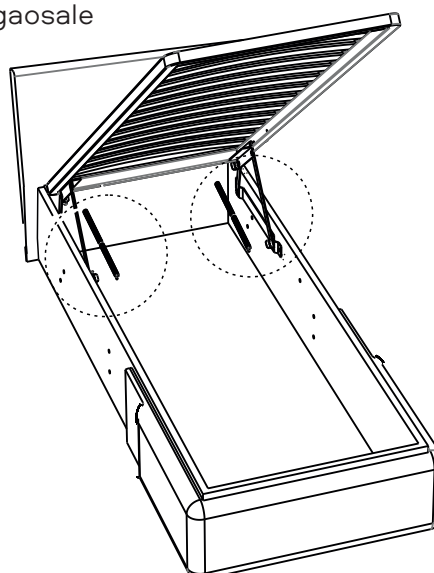
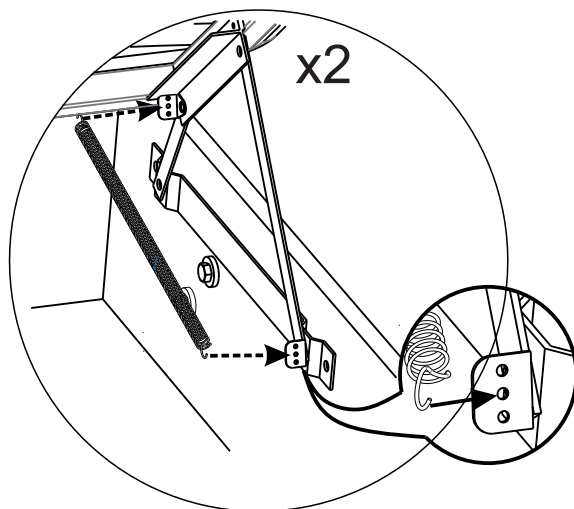

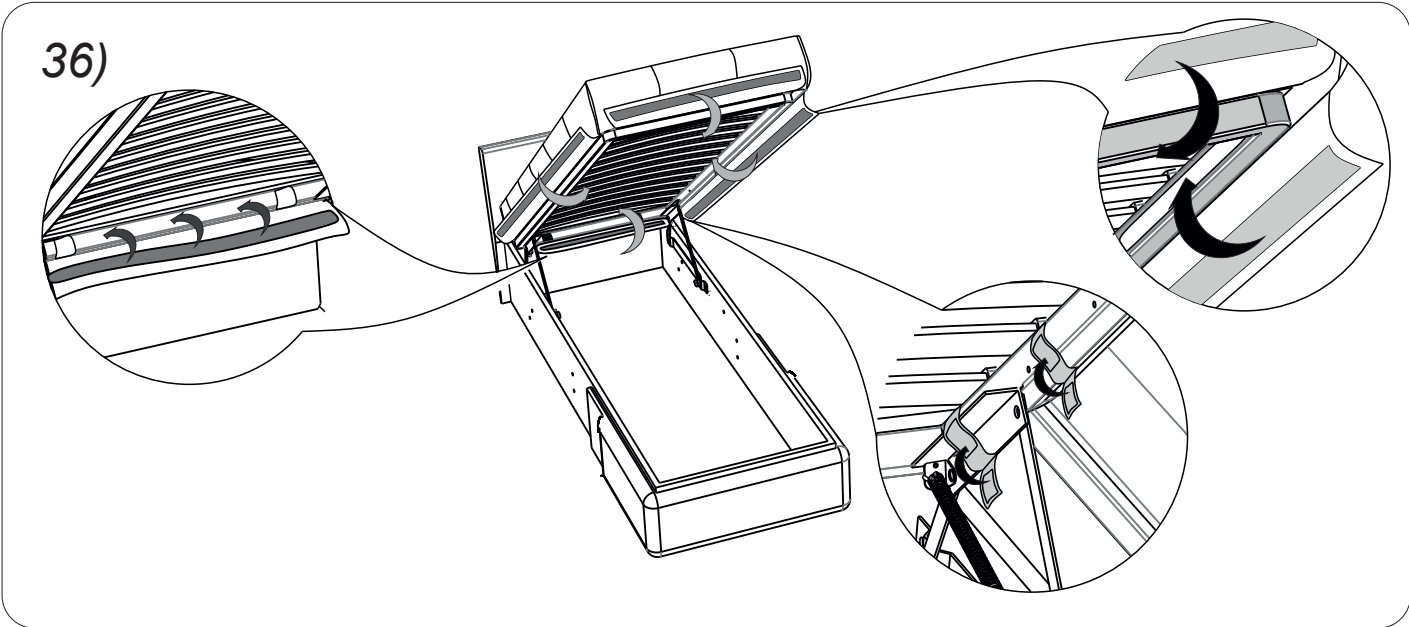
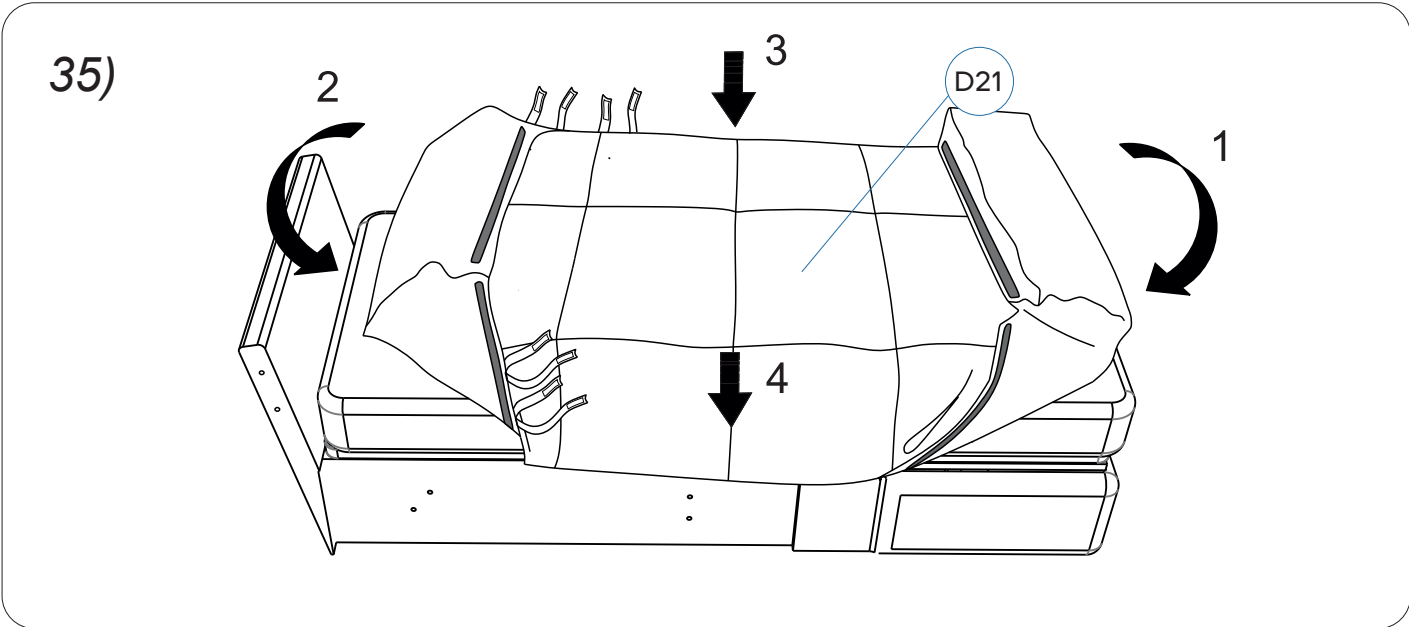
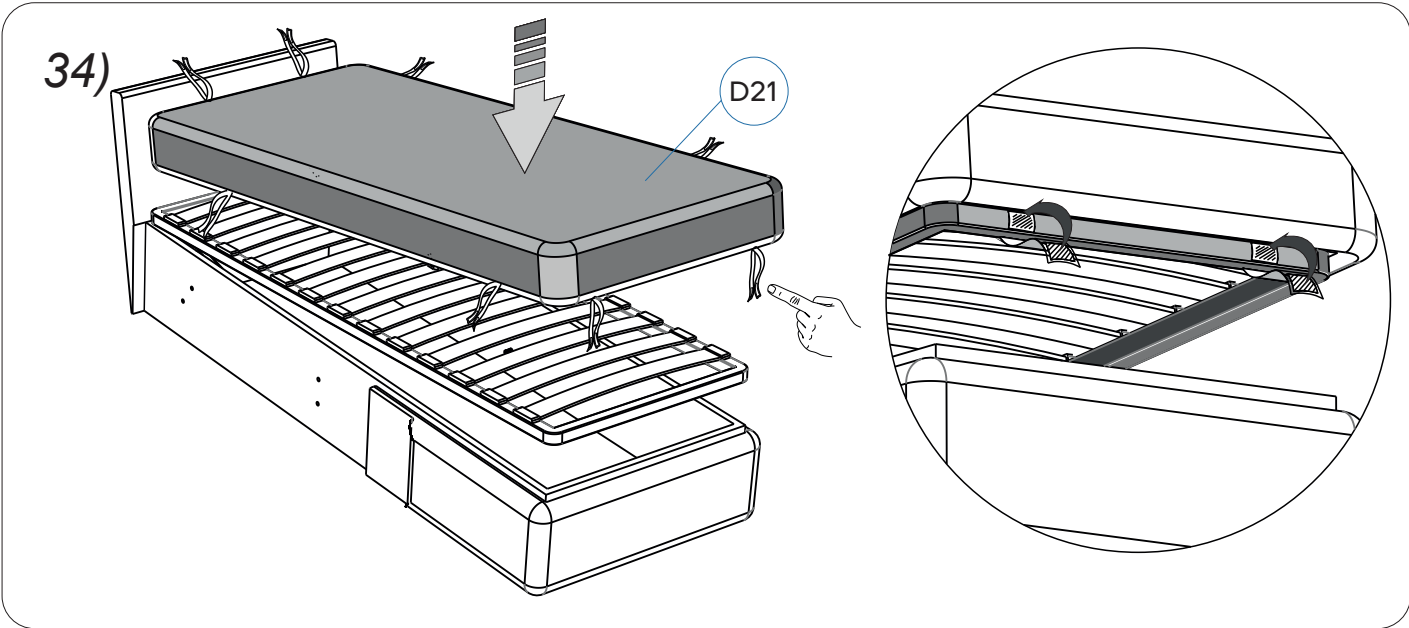

37)

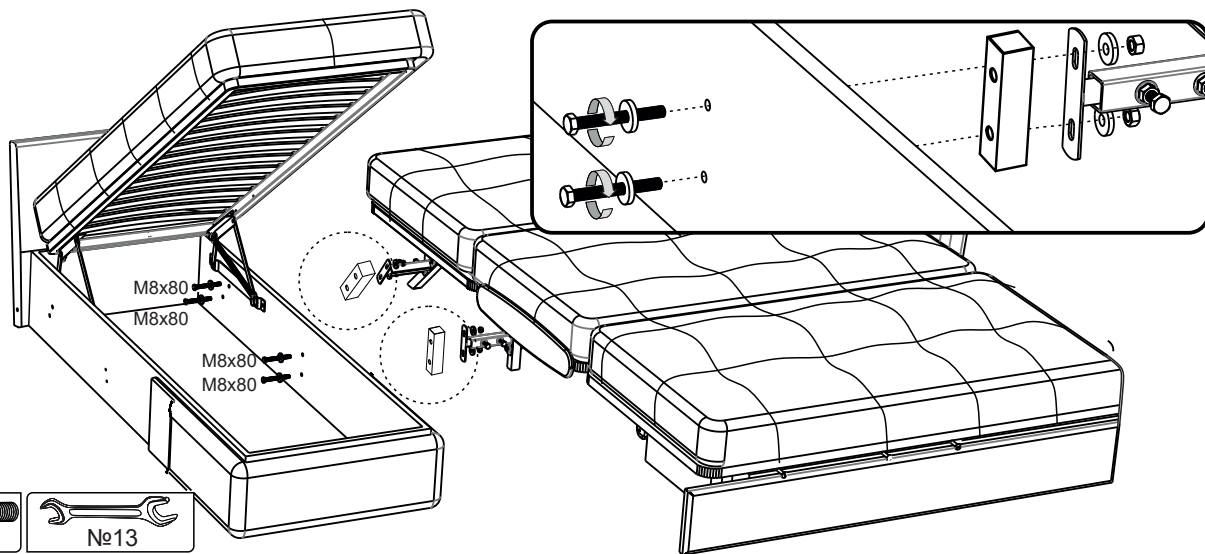

38)

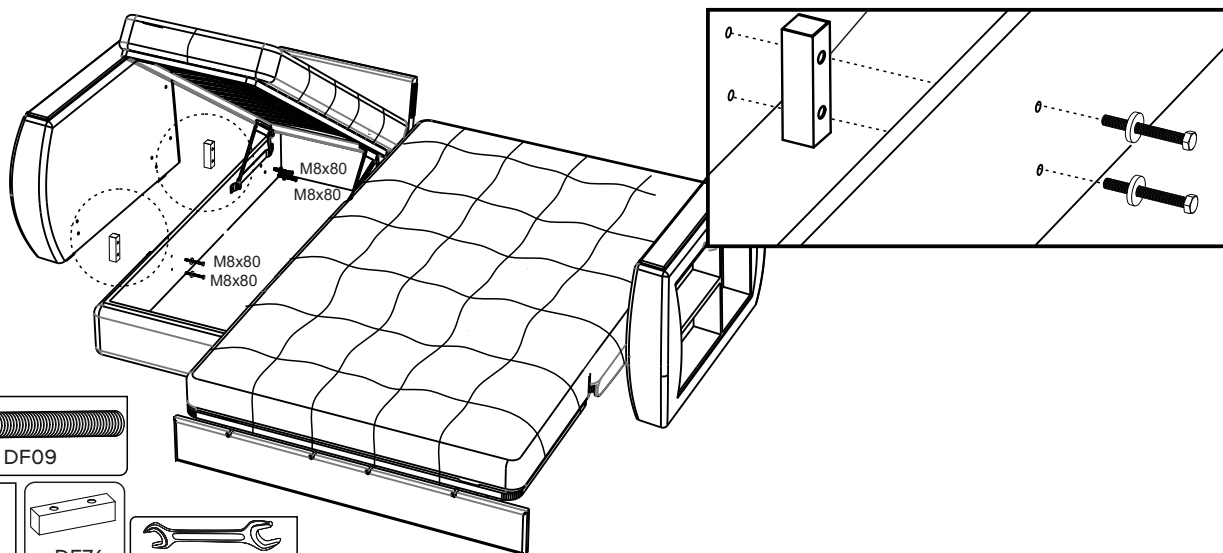

39)

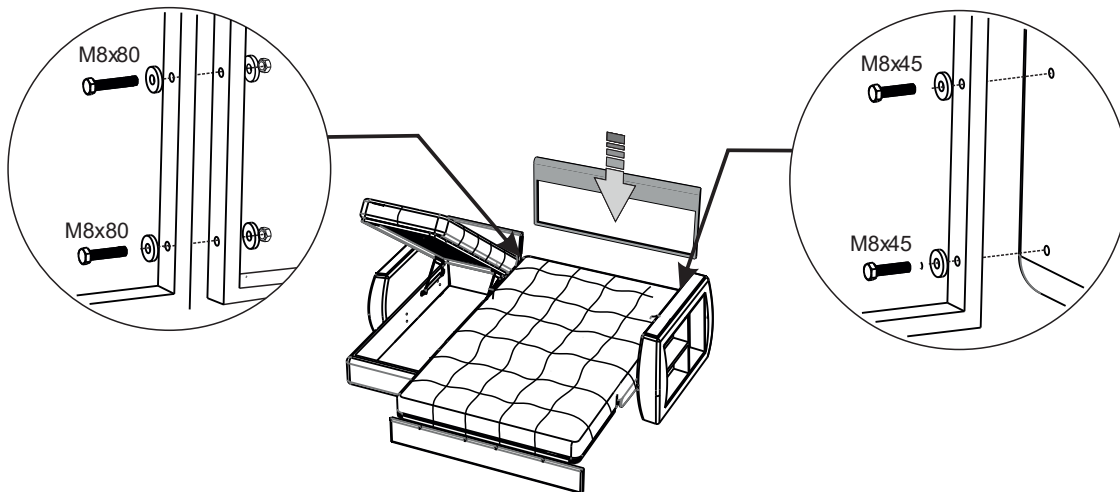



40)

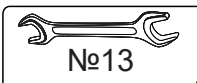
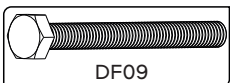
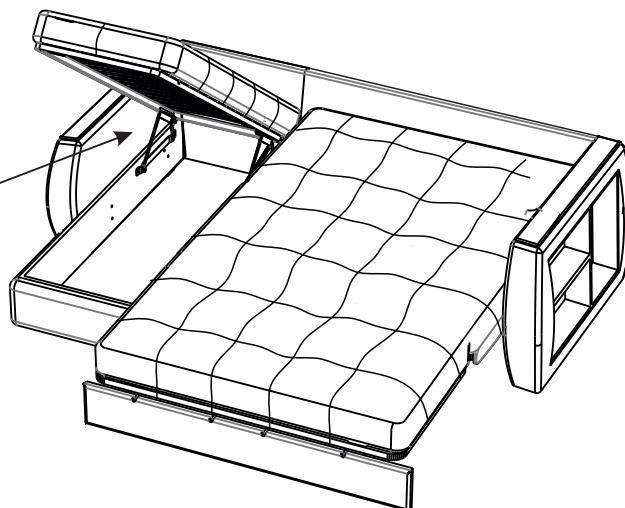
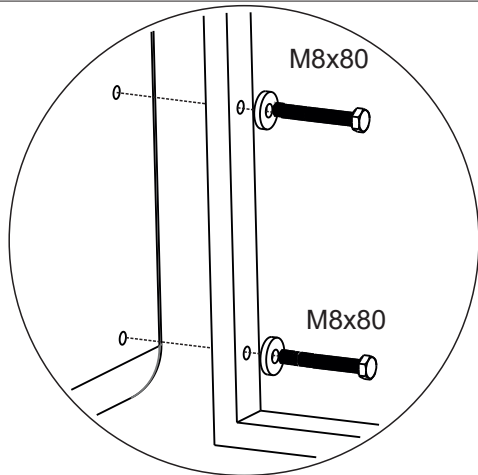

41)

1

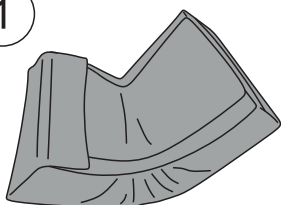

2

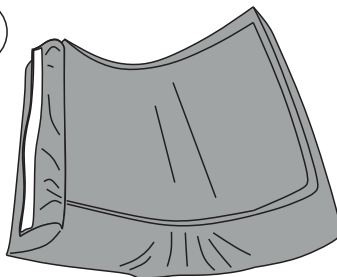

3

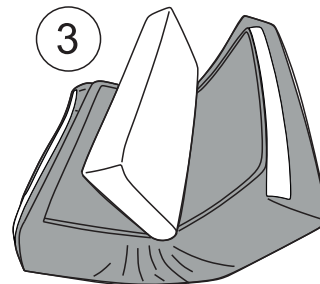

4

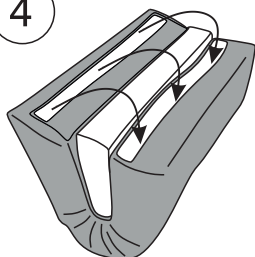

5

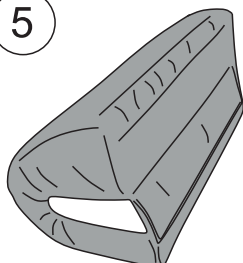

6

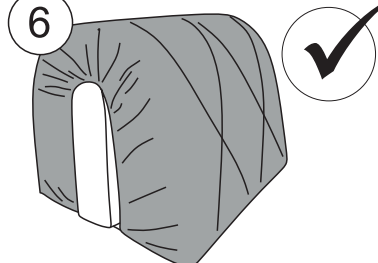

42)

b

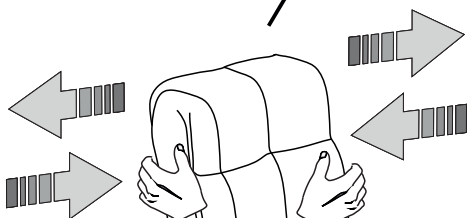

a

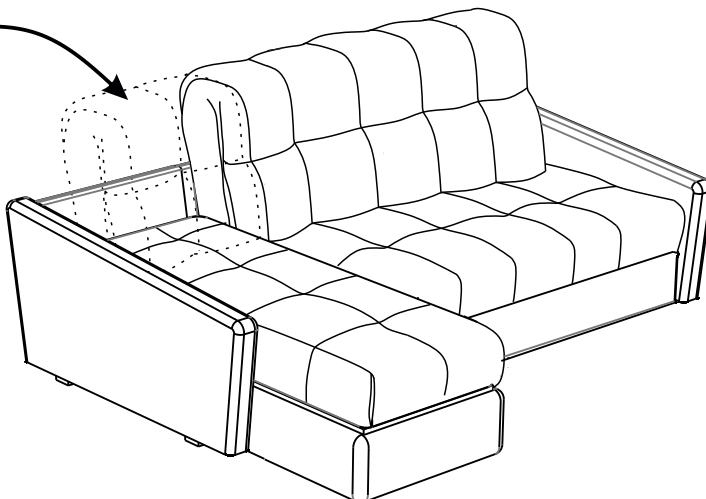



43)

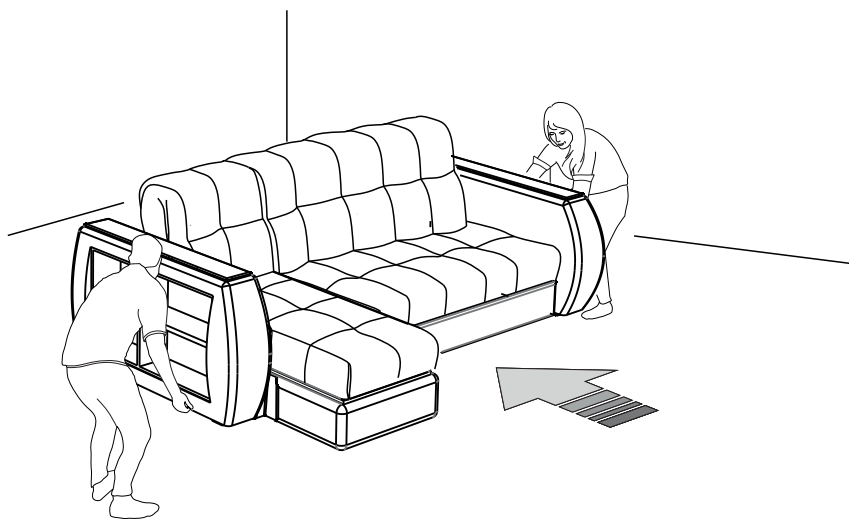

Paigaldage diivanit alaliseks kasutamiseks

44)

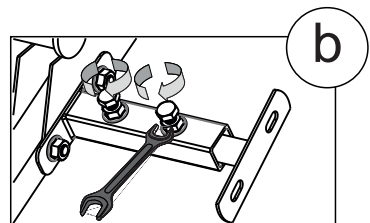
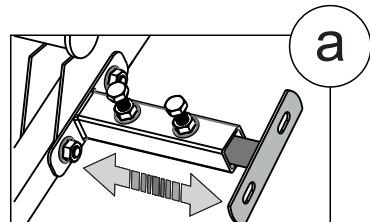
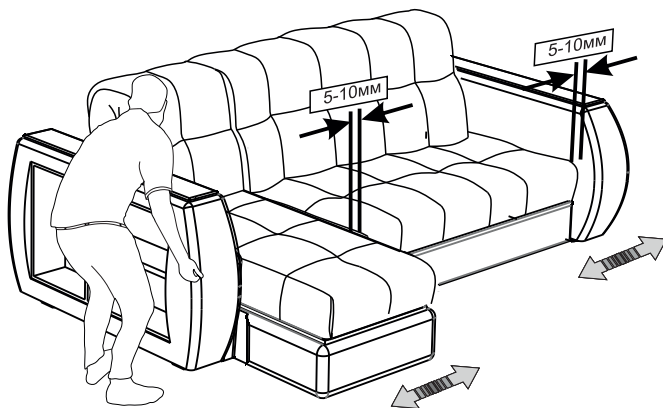

Kinnitage!



45)

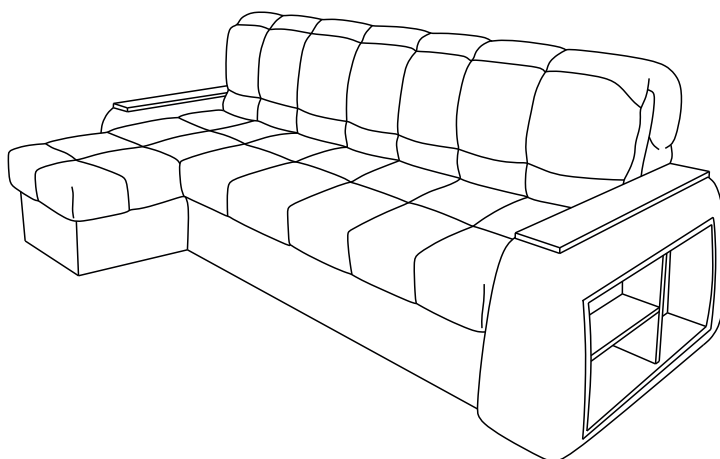

Diivani ümberkujundamise järjekord

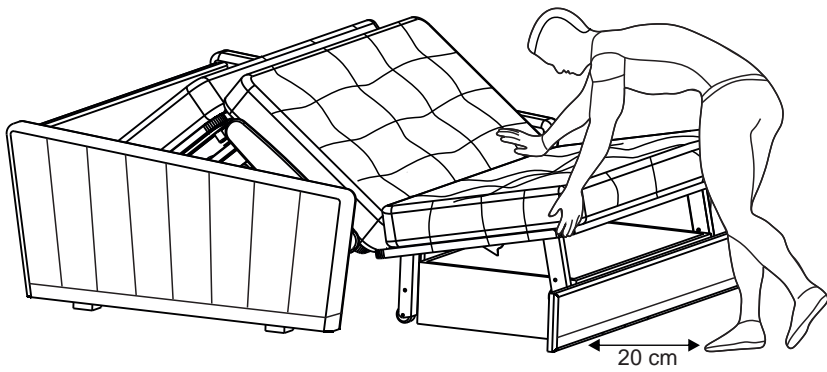
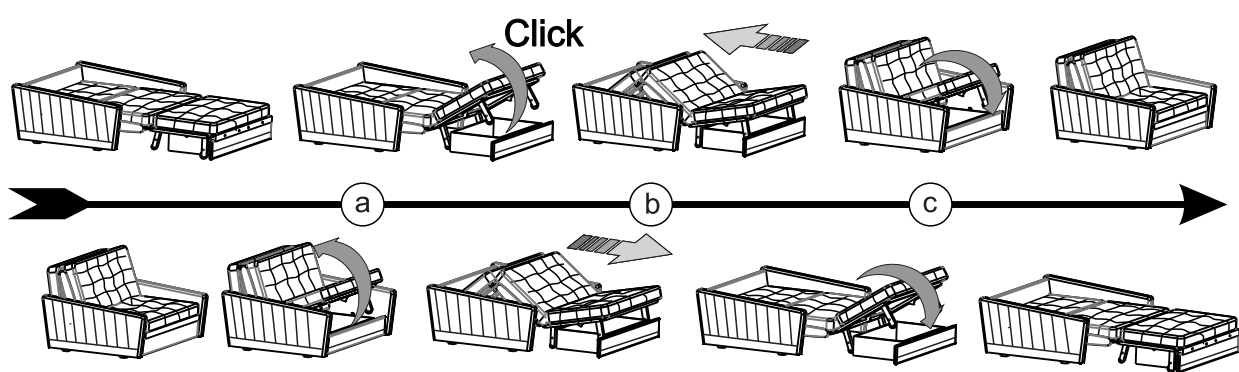

Kui diivani iste ei tõuse üles, vabastage transpordi takjapaelad.

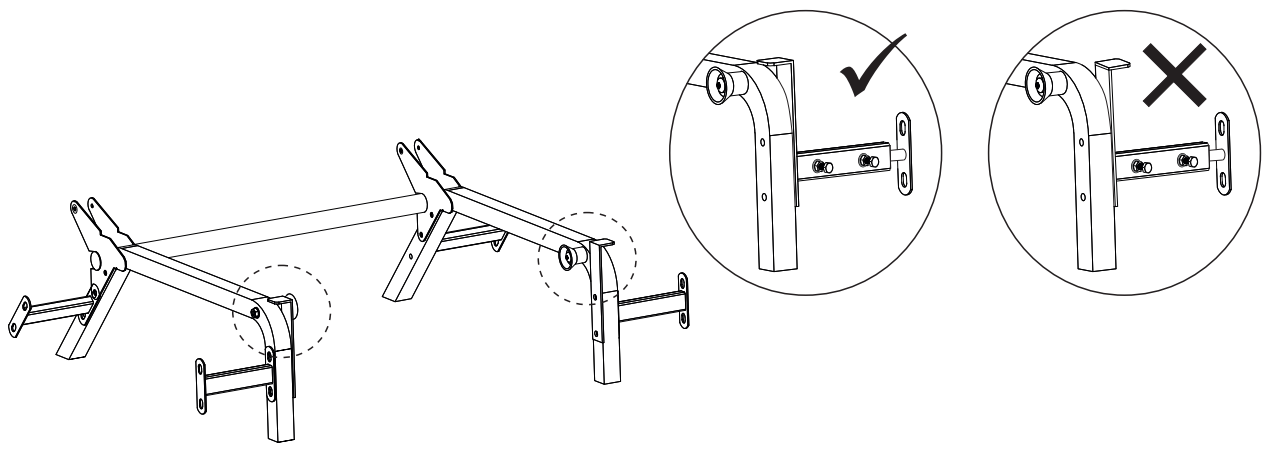

Kui diivani iste ei lähe sisse, kontrollige tugevde asendit mehhanismil.

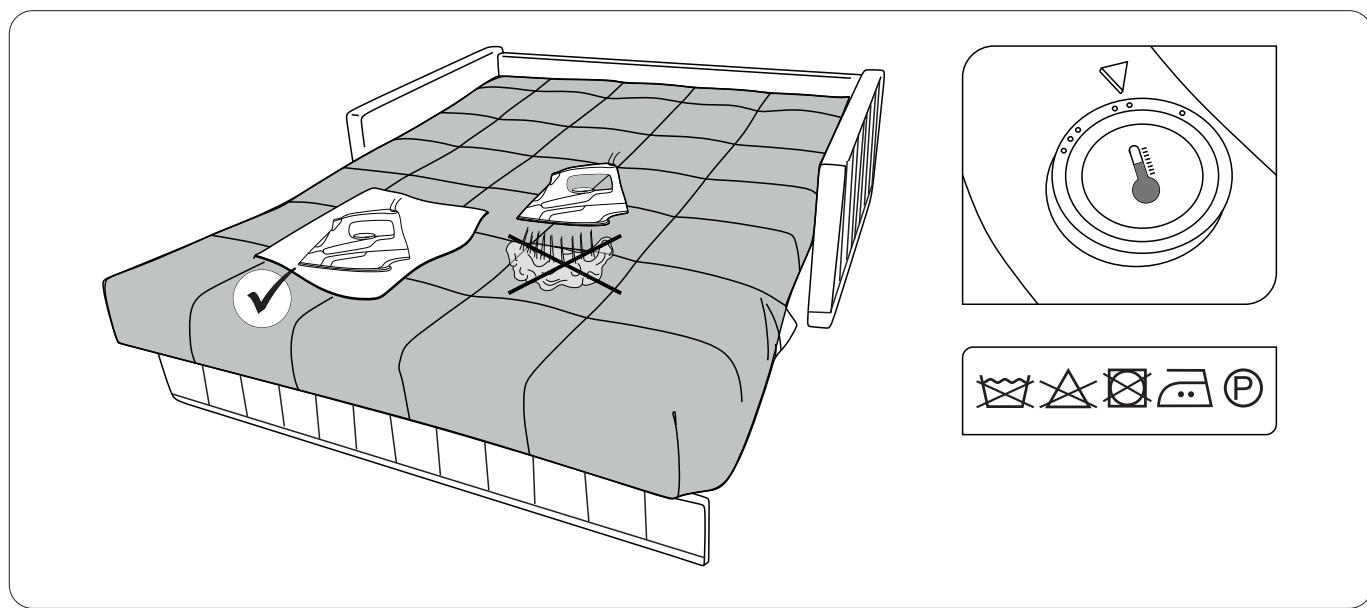
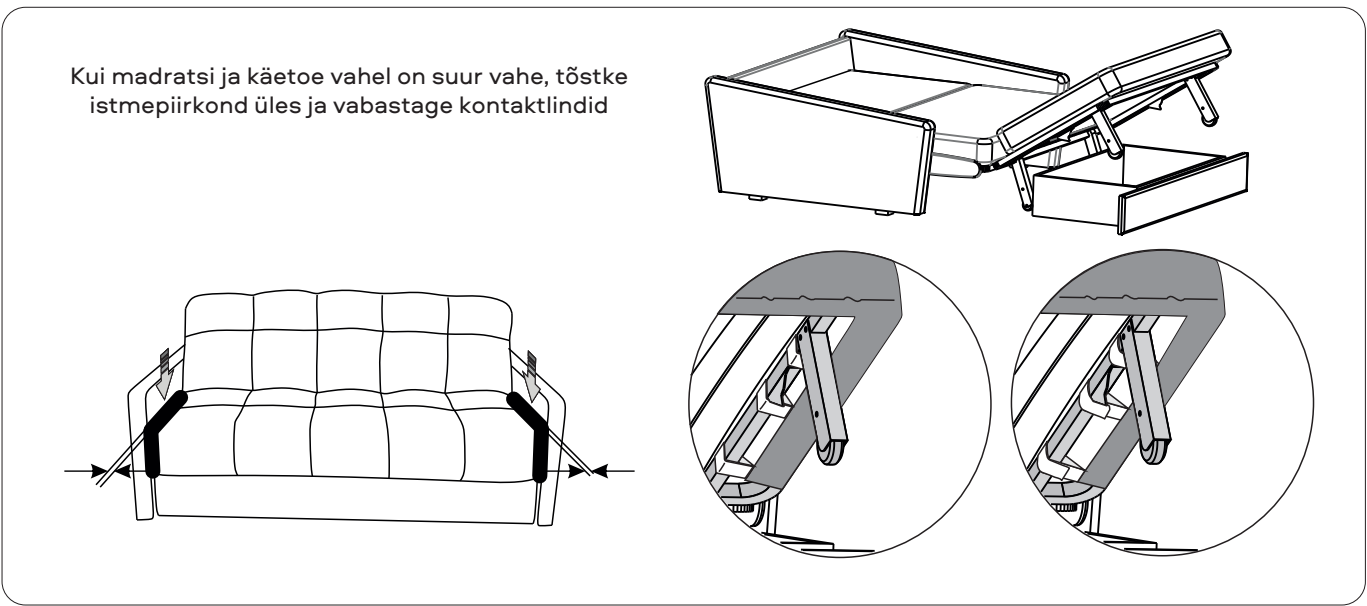
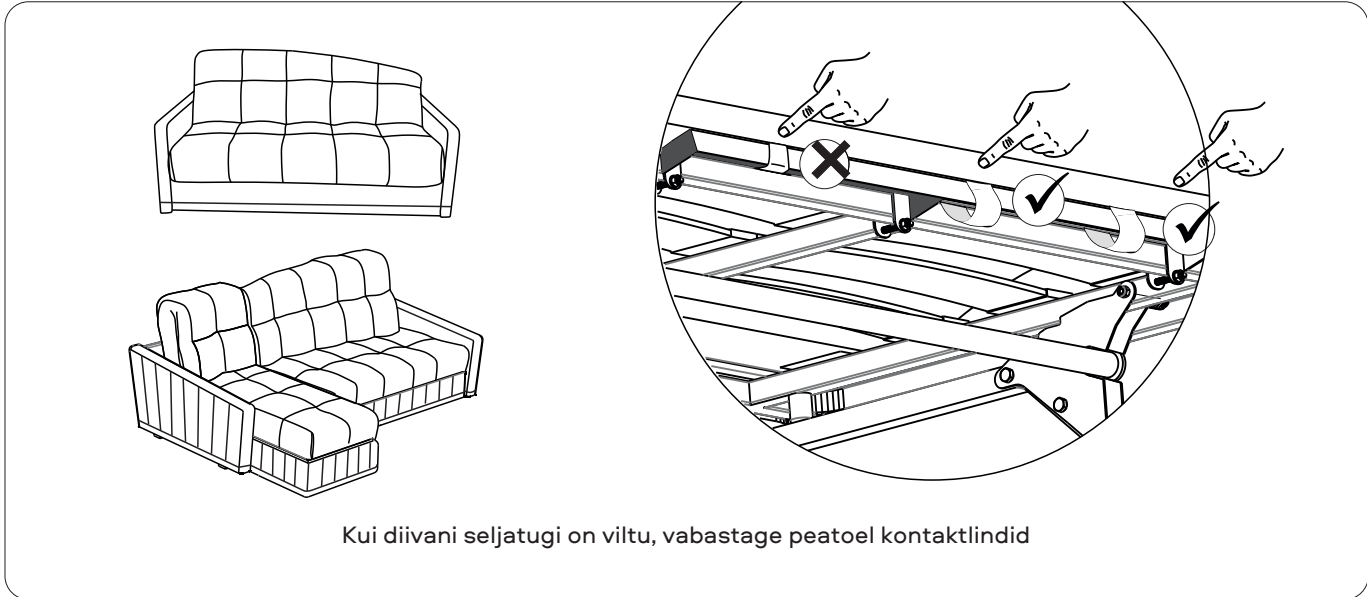

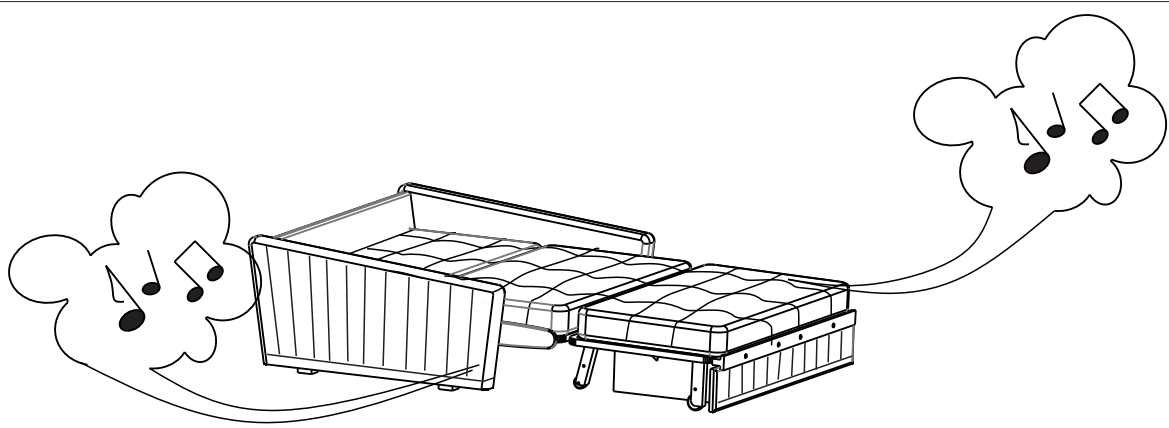

Pidage meeles: Mehhanismi metallelementide iseloomulik kriikumine pideva ümberkujundamise ajal on tavaline. Diivani aluses on usaldusväärne metallkonstruktsioon, mis võimaldab teil diivanit iga päev voodiks muuta. Ümberkujundamise ja töö käigus võib mehhanismi erinevate sõlmede vaheline määrdeaine kuivada ja ilmned metallelementide hõõrdumine üksteise vastu. Selle hõõrdumise ja mehhanismi kriikumise vältimiseks ümberkujundamise või kasutamise ajal on oluline järgida järgmisi soovitusi: Kriikumise korral määrige mehhanismi hõõrdeelemendid, pingutage ühendused. Määrige vähemalt 1 kord 6 kuu jooksul.

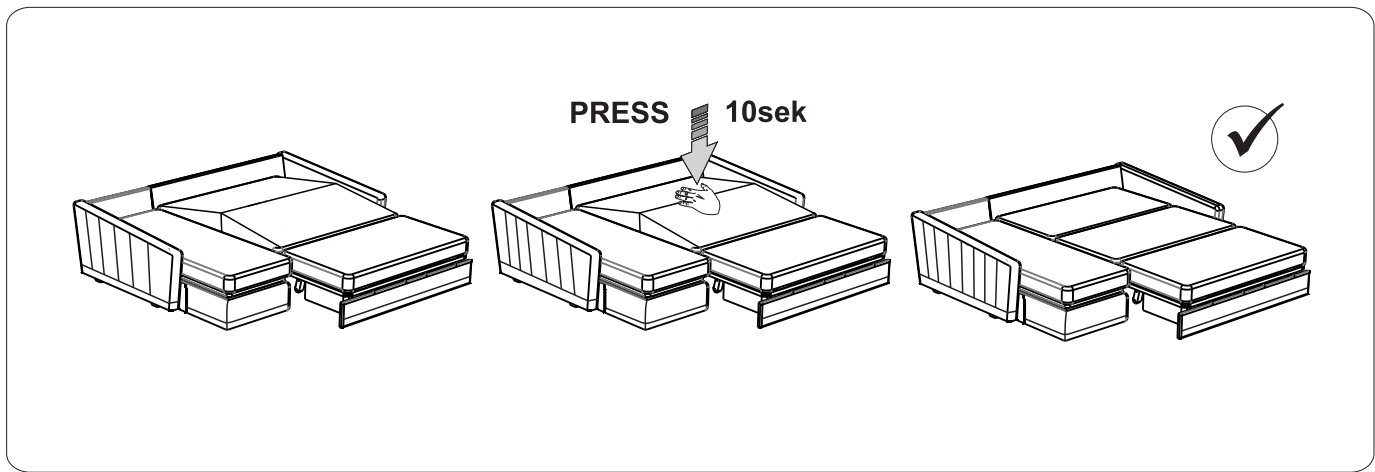
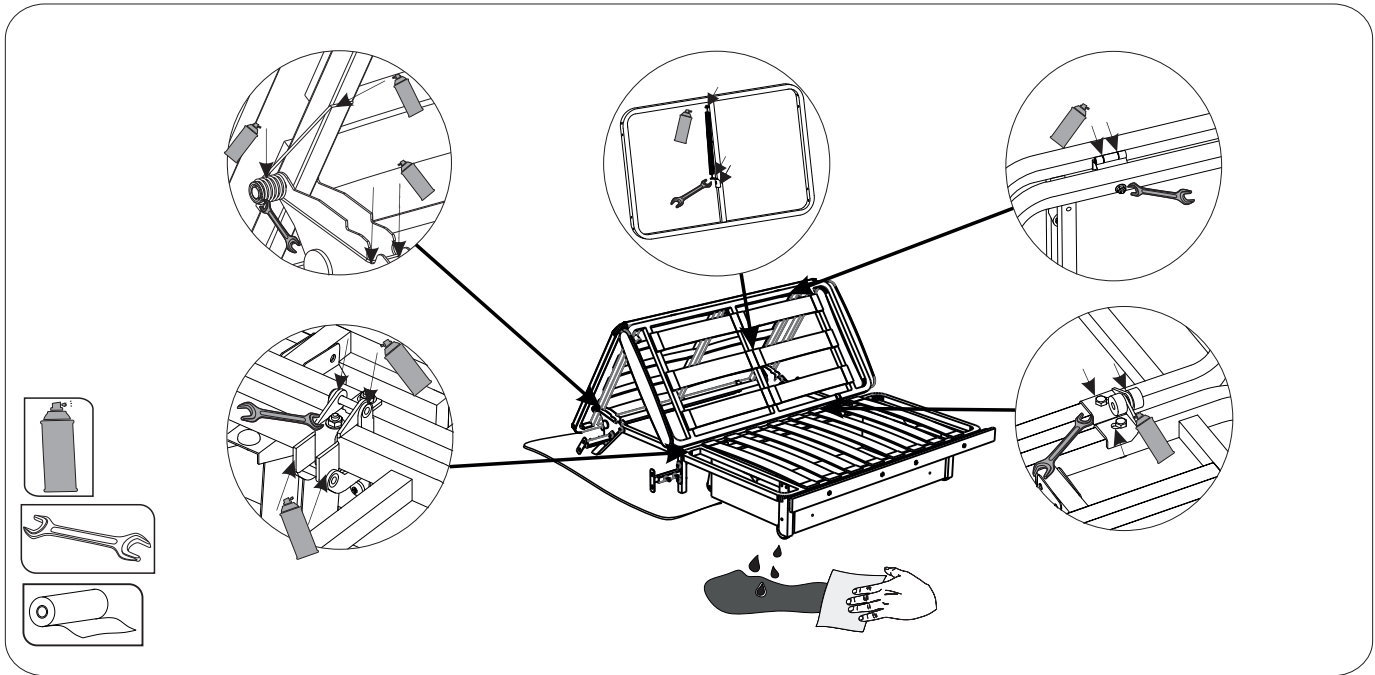

Vajutage 10 sec.

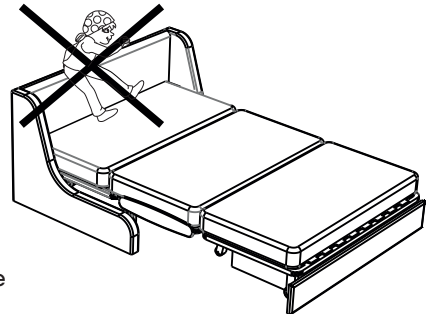
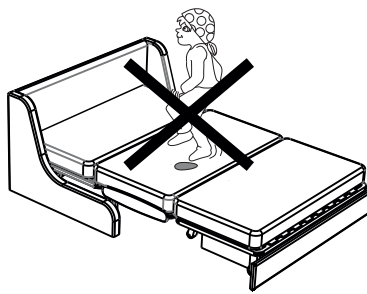
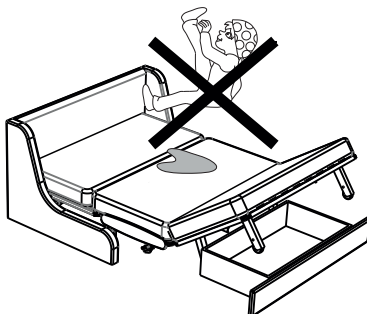
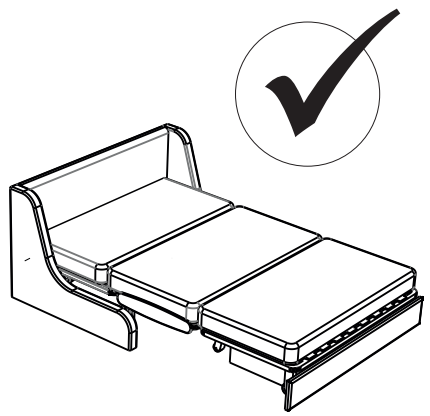
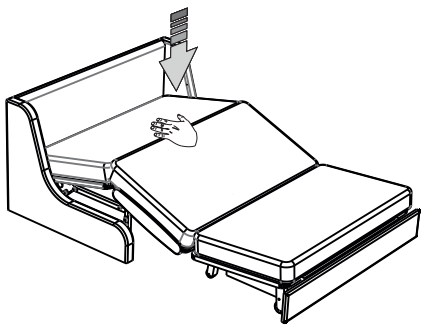
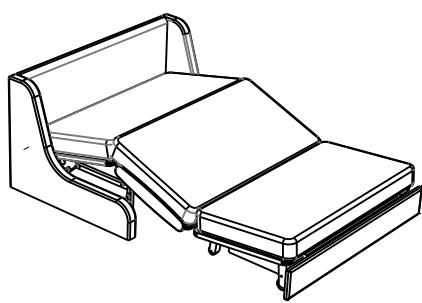

Ärge istuge peatoel

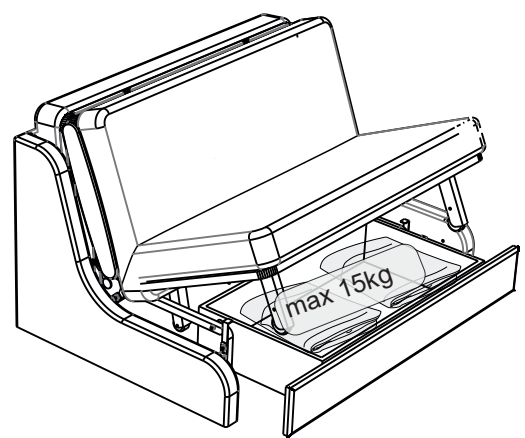
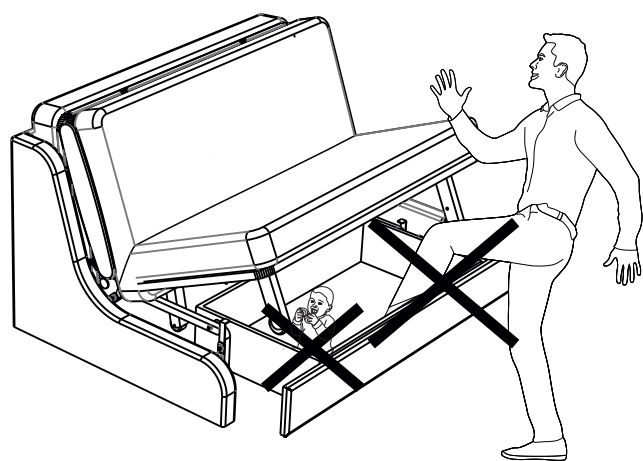





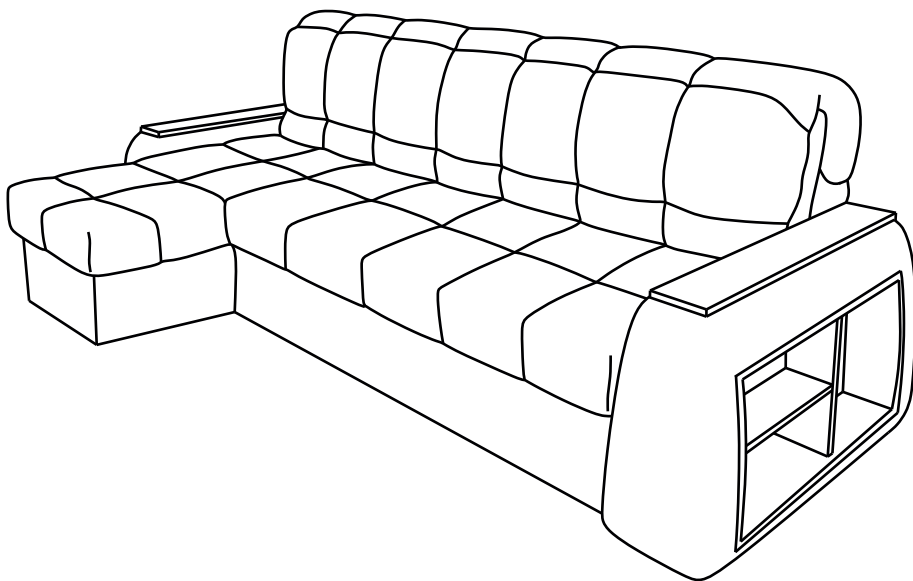
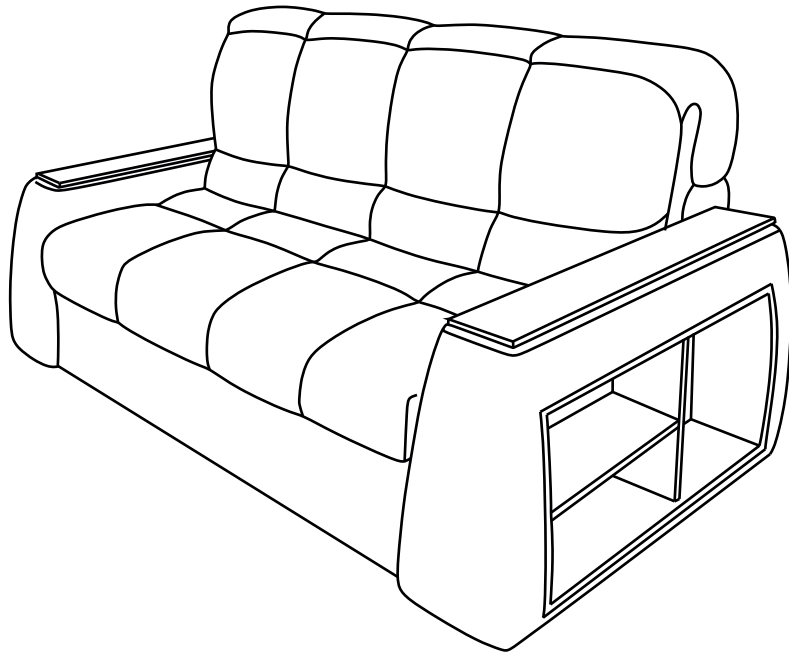

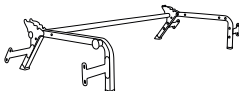

# SUNSET NOVA

RO



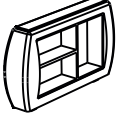
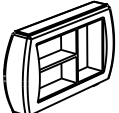



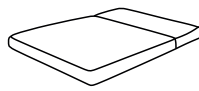
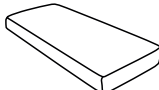

Sleep.8

## Ansamblul canapelei

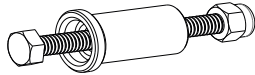

Ambalare	Piesa	Nº de produs	Denumire	Cantitate
Nº 1		D01	Mecanismul transformării	1
		D26	Suportul sistemului de extensie	1
		D04	Spatele	1
		D05	Carcasa	1
		D07	Husa matlasată	1
			Pachet cu fitinguri	1
			Instrucțiuni pentru asamblare	1
Nº 2		D06	Cotiera	1
Nº 3		D06	Cotiera	1
Nº 4 opțiune suplimentară la comanda unei canapele		D14	Canapea	1
		D11	Pentra pentru canapea	1
		D08	Husa pentru canapea, eșantion de tapiterie	1
			Pachet cu fitinguri	1
			Instrucțiuni pentru asamblare	1
Se livreaza separat		D20	Saltea	1
		D21	Canape mattress	1

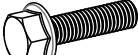

## Sofas

Ambalare	Piesa	№ de produs	Denumire	Cantitate
Pachet cu fittinguri		DF02 DF15 DF16	Șurub M6x65 Bucșă din plastic Piuliță M6 (cu autoblocare)	2
		DF11	Șurub cu cap înecat M6x30	3
		DF31	Arc cu cârlige	2
		DF06	Șurub M8x45	4
		DF56	Șurub M8x30	8
		DF42	Șaibă M8	4

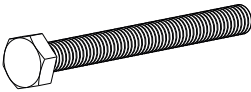

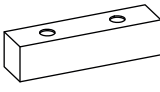
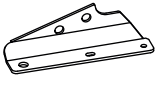
## Canape

Ambalare	Piesa	№ de produs	Denumire	Cantitate
Pachet cu fittinguri		DF30	Arc pe canapea (numai pentru canapea mică)	2
		DF09	Șurub M8x80	10
		DF19	Piuliță M8	6
		DF42	Șaibă M8	14
		DF74	Panoul de finisare pentru canapea	4
		DF75	Oprirea mecanismului	2

### Înainte de asamblare:

- 1. Verificați aspectul și integritatea pieselor din pachet!** Reclamațiile pentru daune sunt acceptate numai pentru produsele FĂRĂ urme de asamblare.
- 2. Păstrați ambalajul și instrucțiunile până la sfârșitul asamblării!** Dacă în timpul procesului de asamblare ați detectat un defect și o incompletitudine a produsului, trebuie să salvați ambalajul până când un reprezentant al societății comerciale vine la domiciliul dvs.
- 3. Verificați numărul de piese și fittinguri conform listei.** Producătorul își rezervă dreptul de a aduce modificări de proiectare produsului, de a înlocui fittinguri și feronerie cu altele similare care nu înrăutățesc aspectul și nu afectează proprietățile funcționale ale produsului. În caz de incompletitudine sau defecțiune, înconjurați numărul piesei lipsă și informați magazinul pentru înlocuirea acestuia.
- 4. Respectați ordinea de asamblare dată în acest manual!** Nerespectarea instrucțiunilor de asamblare și de utilizare va anula garanția producătorului.
- 5. Alegeți o zonă de podea plană pentru a instala canapeaua extensibilă!** Cu curburile podelei și covoarele înalte, sunt posibile abateri în funcționarea mecanismului de transformare a canapelei extensibile, distorsiuni în forma produsului.
- 6. Asamblați canapeaua extensibilă cu un partener.** Mutați toate piesele cu atenție, fără a smuci, așezați-le în siguranță, evitați căderea și impactul asupra lor!
- 7. Mutați mobilierul și piesele sale ridicându ușor mobilierul.** Acest lucru va elimina deformările și rupturile.
- 8. Asigurați-vă că lubrifiați mecanismul de ridicare în timpul asamblării conform instrucțiunilor!** Acest lucru va evita scârțâitul prematur. Lubrifiați din nou, strângeți șuruburile și piulițele slăbite, cel puțin o dată la șase luni.

### Pentru a asambla canapea, veți avea nevoie de:

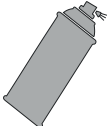
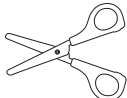
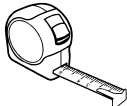
	Phillips-head screwdriver
	Cheie cu dinte №13 x 1 Cheie cu dinte №10 x 2
	Prosop de hârtie
	Spray-ul siliconic lubrifiant
	Foarfece
	Ruletă

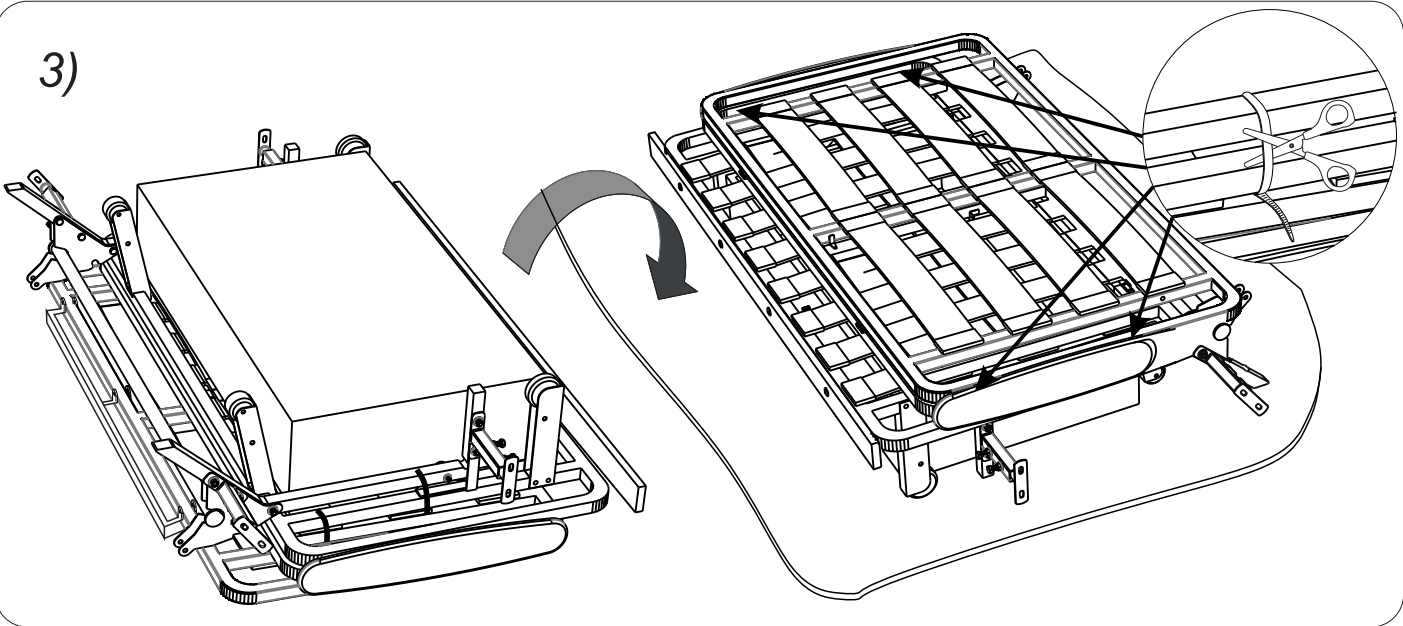
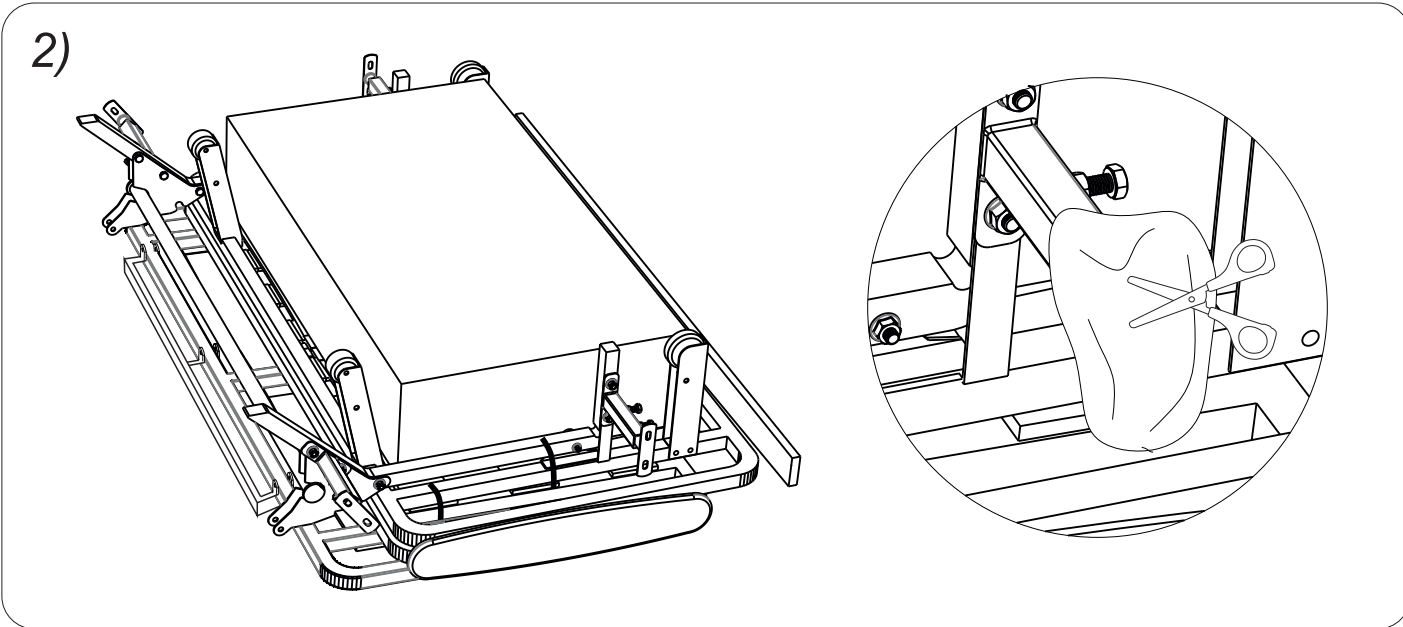
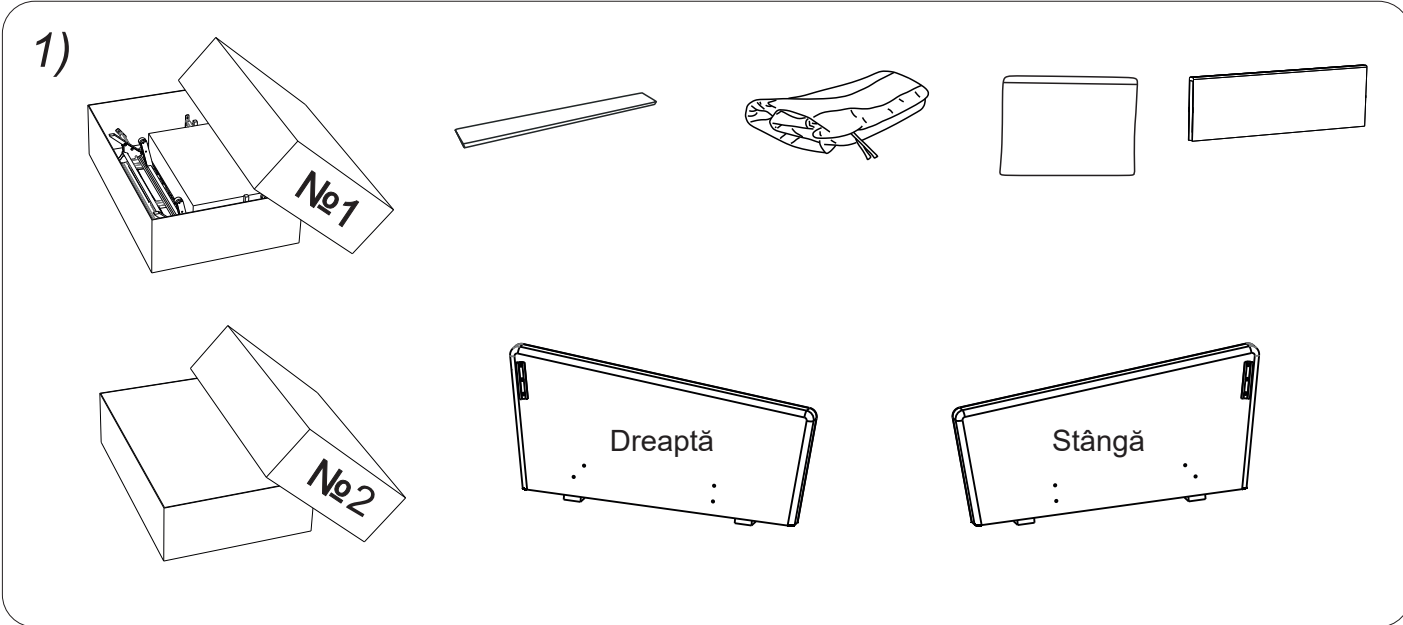

4)

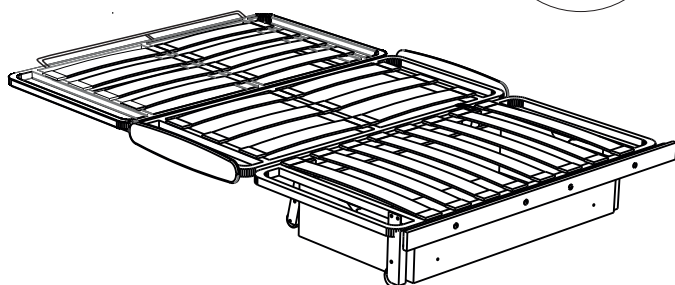
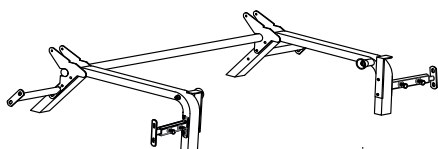
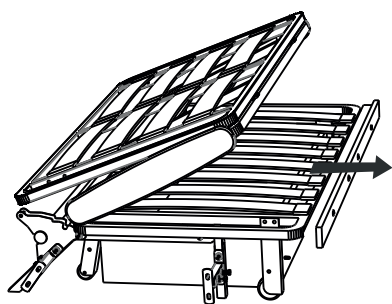

Scoateți cadrul de pe soclu

5)

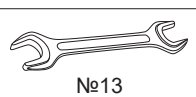
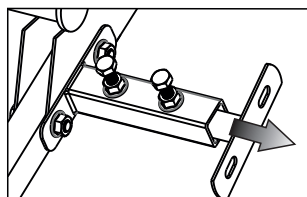
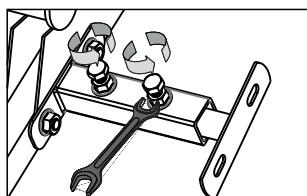

№13

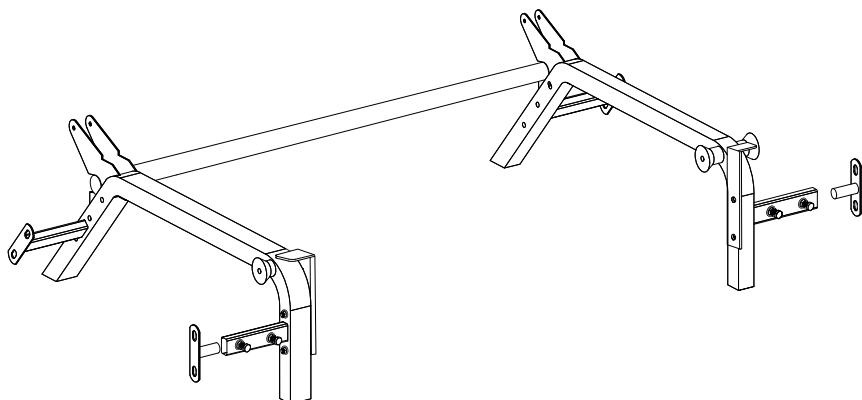

6)

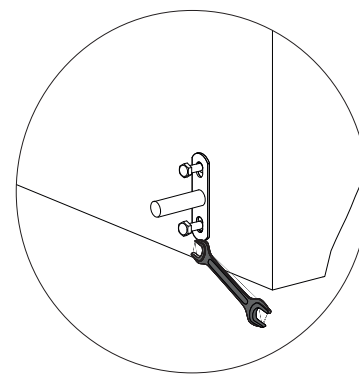
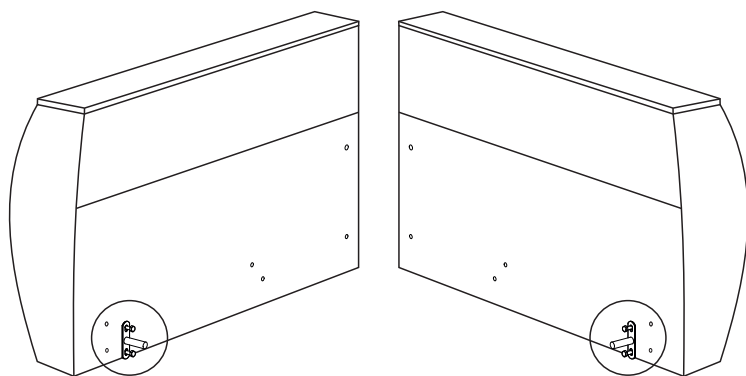

DF56

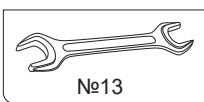

№13

Când asamblați o canapea de colț, instalați suportul pe o cotieră (din partea opusă canapelei)

7)

Nu strângeți șuruburile suportului

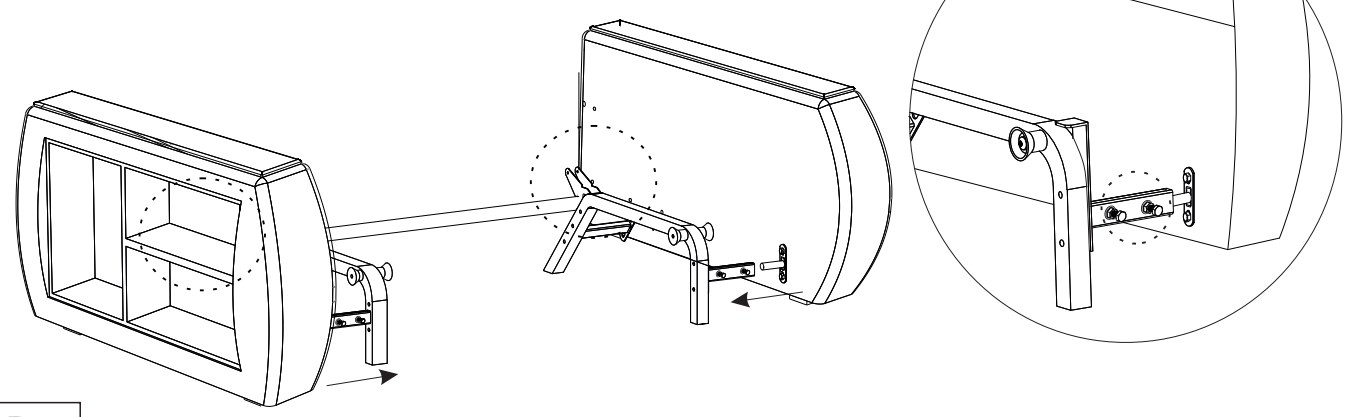

Înșurubați suporturile din spate.  
Nu strângeți șuruburile suportului frontal.

8)

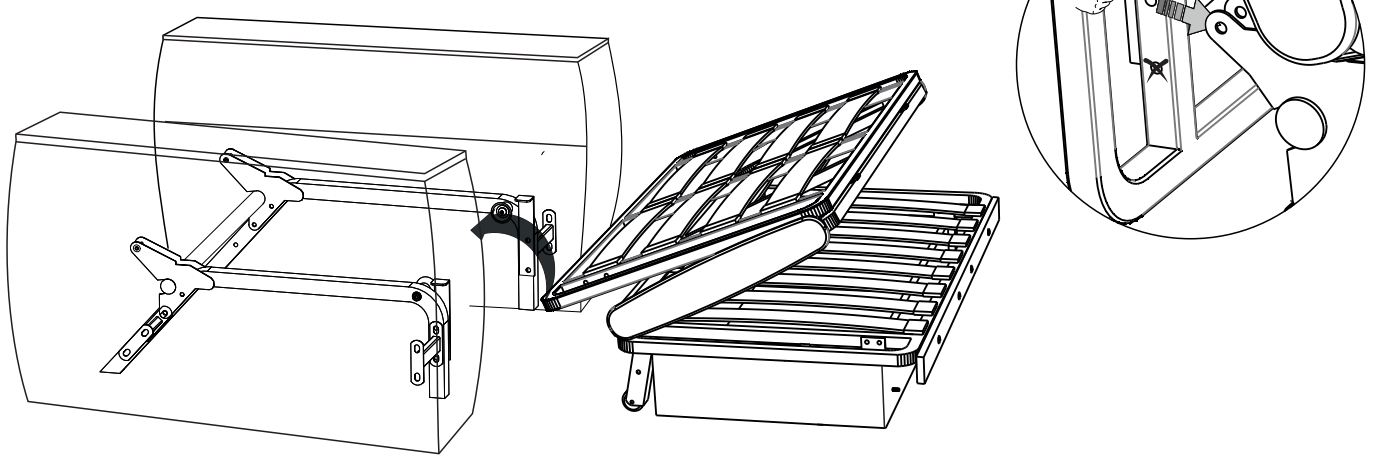

Nu strângeți prea tare

9)

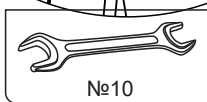
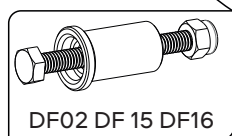
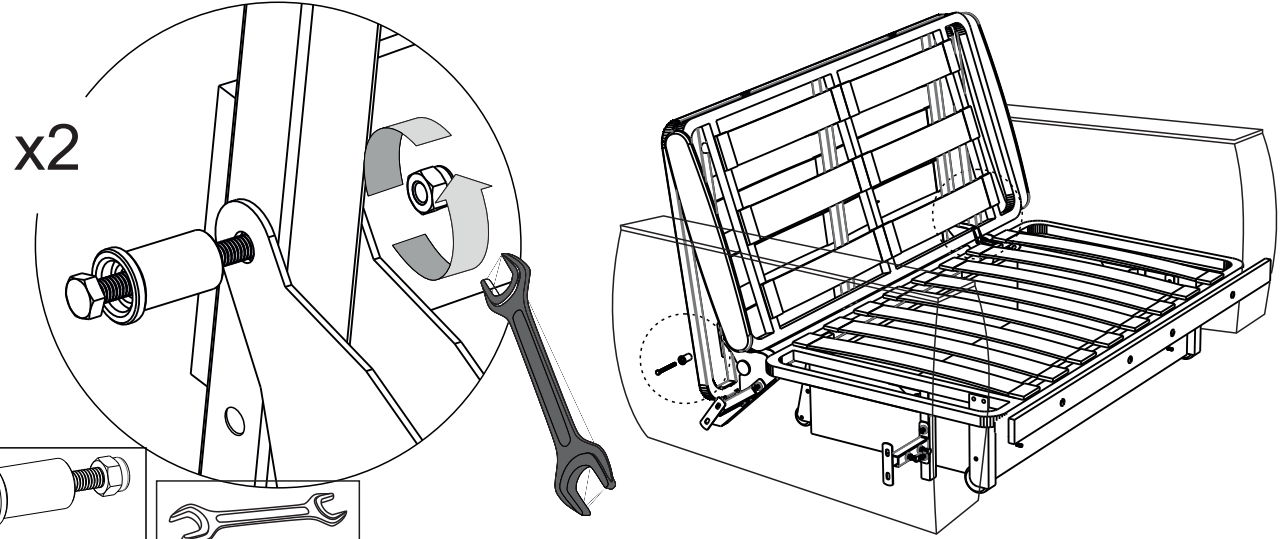

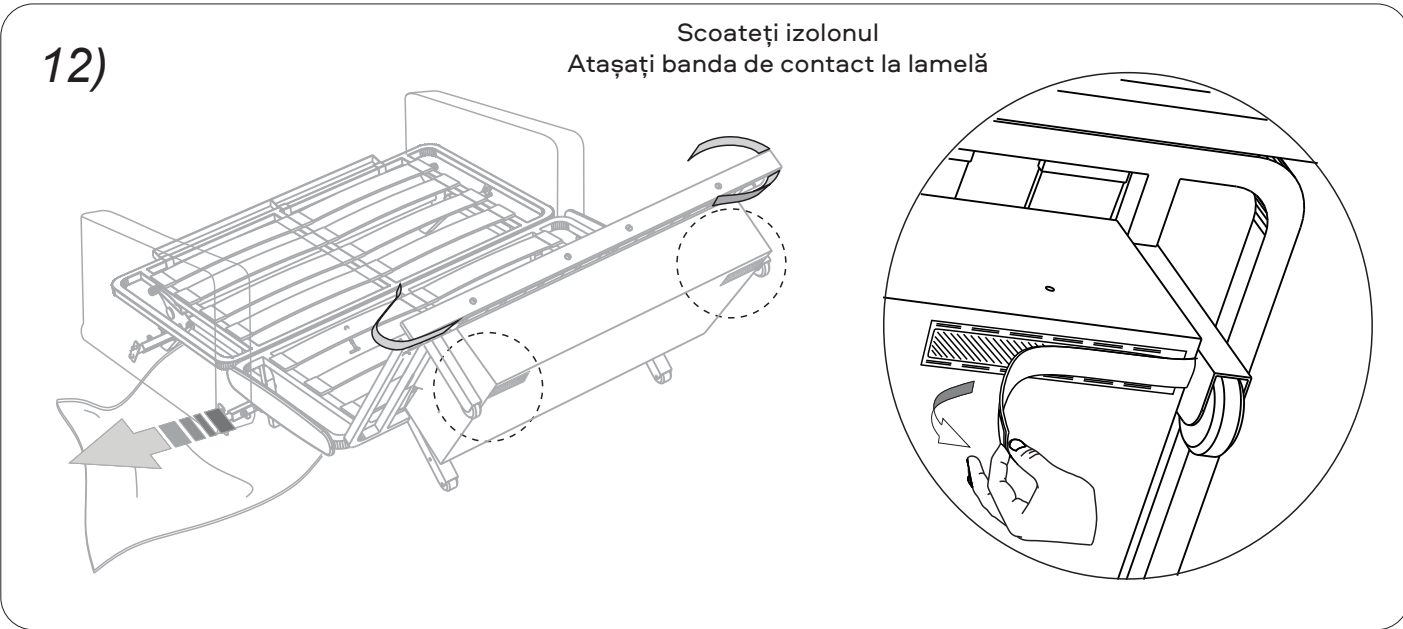
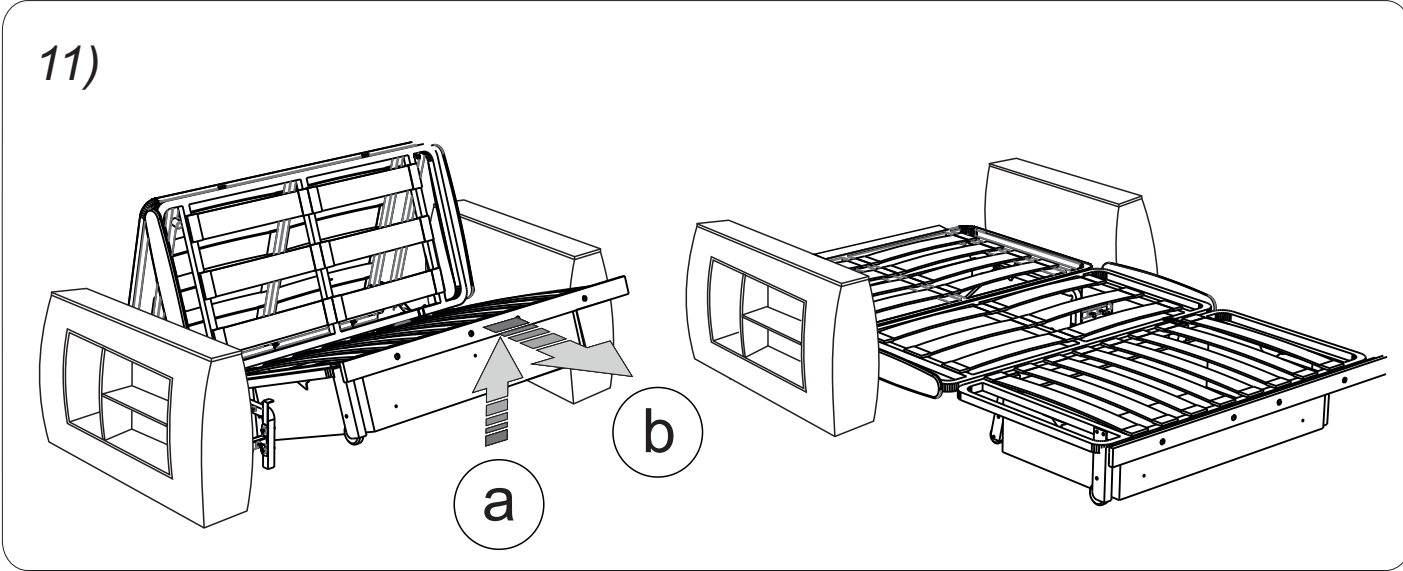
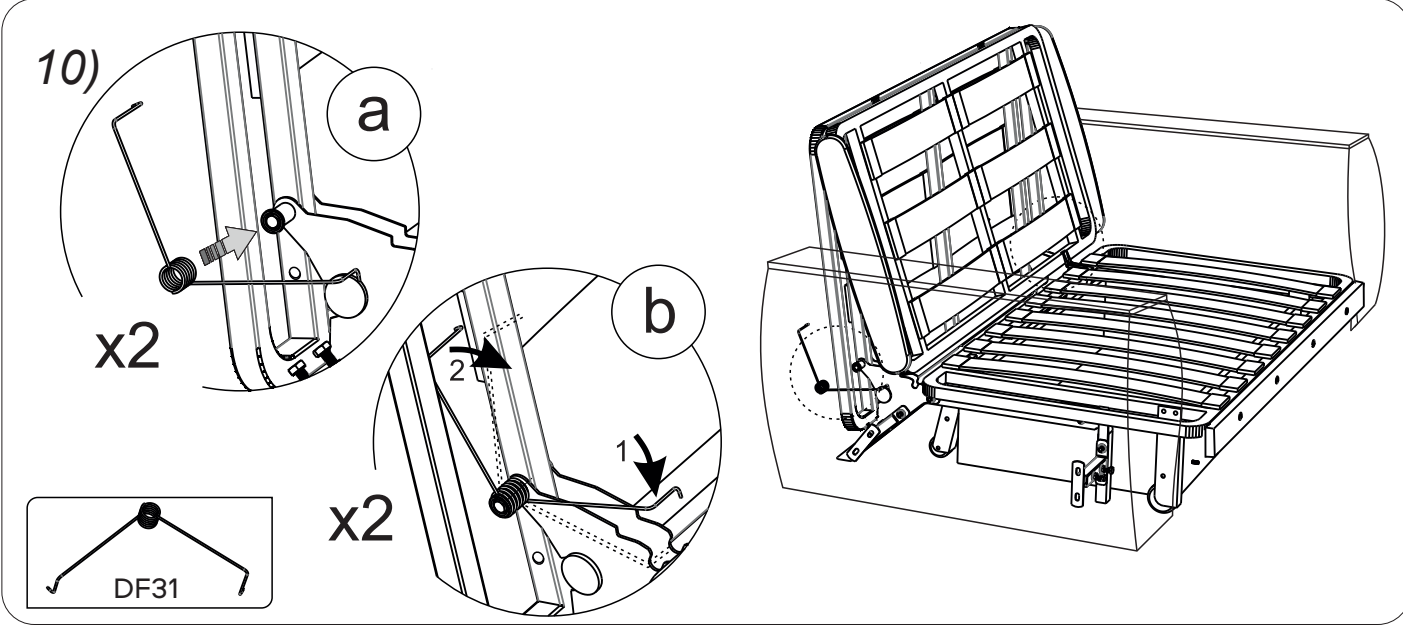



13)

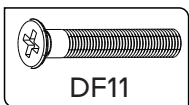
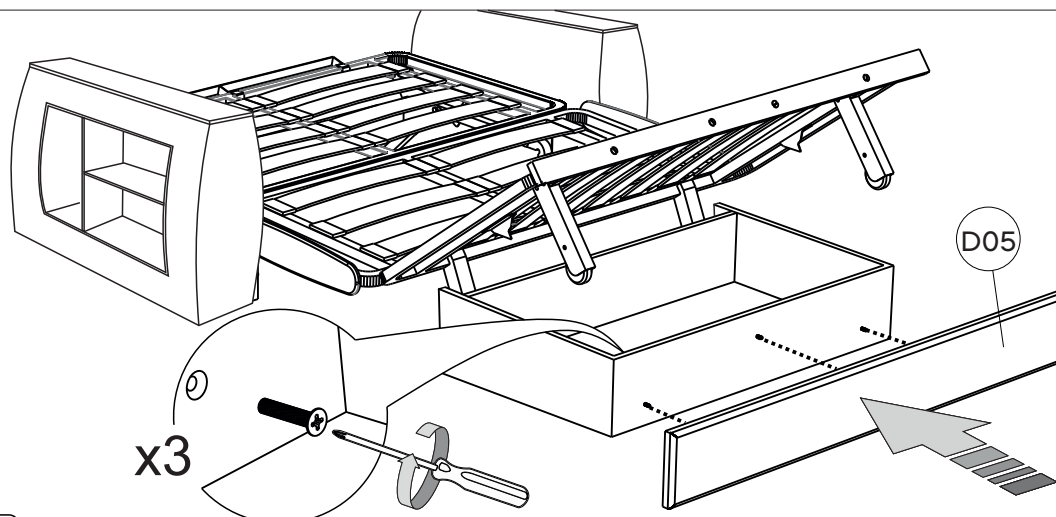

Partea inferioară a elementului de rigidizare este determinată de prezența unei benzi de suport.

14)

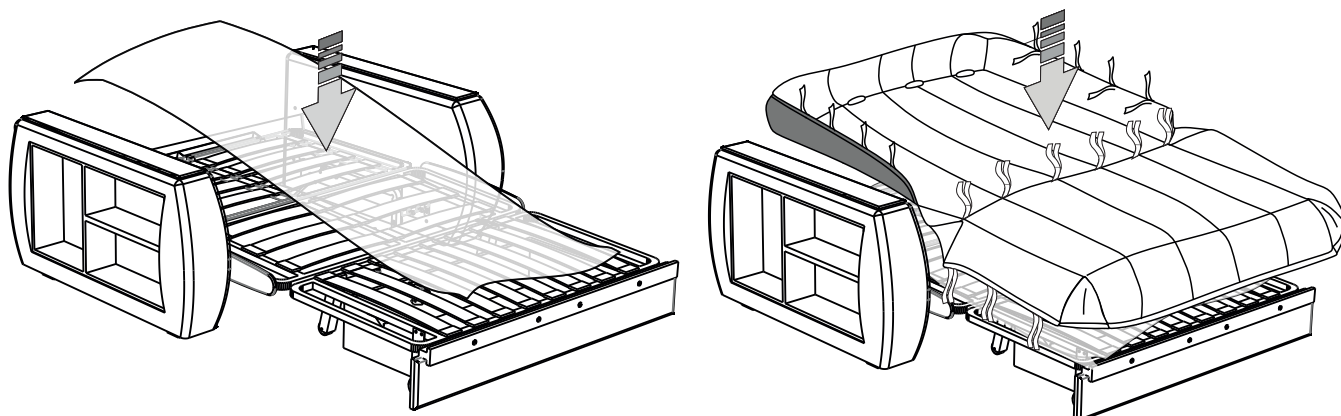

Așezați pelicula din ambalajul canapelei pe mecanism pentru a proteja husa de lubrifiere

15)

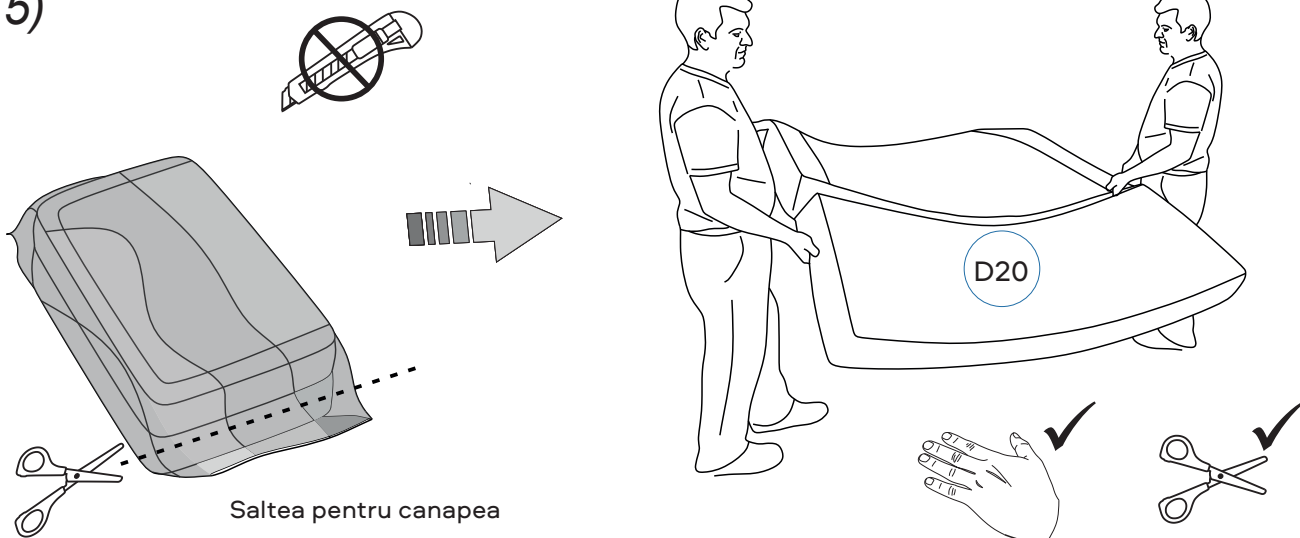

Saltea pentru canapea



16)

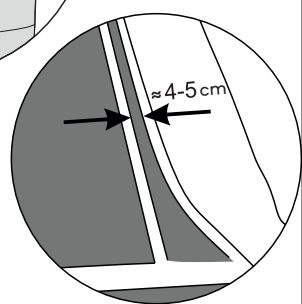
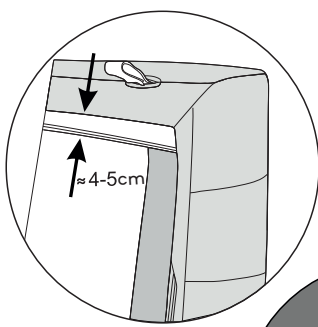
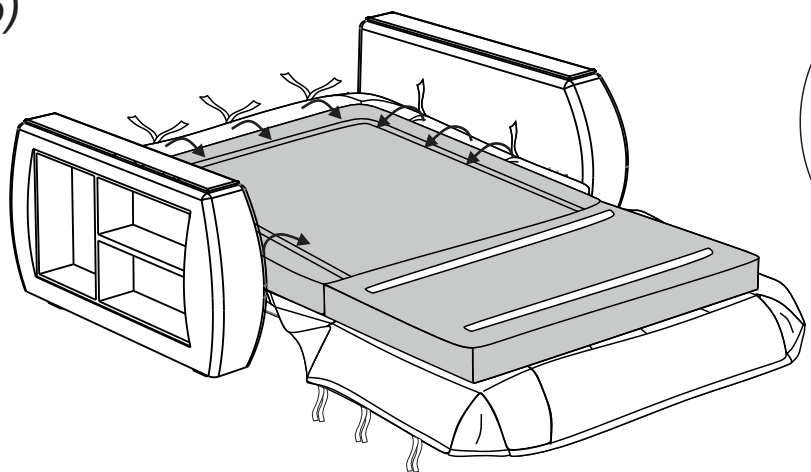

Aliniați cusăturile și colțurile saltelei și ale husei.  
La cap benzile de contact sunt filetate prin orificiile din husa

17)

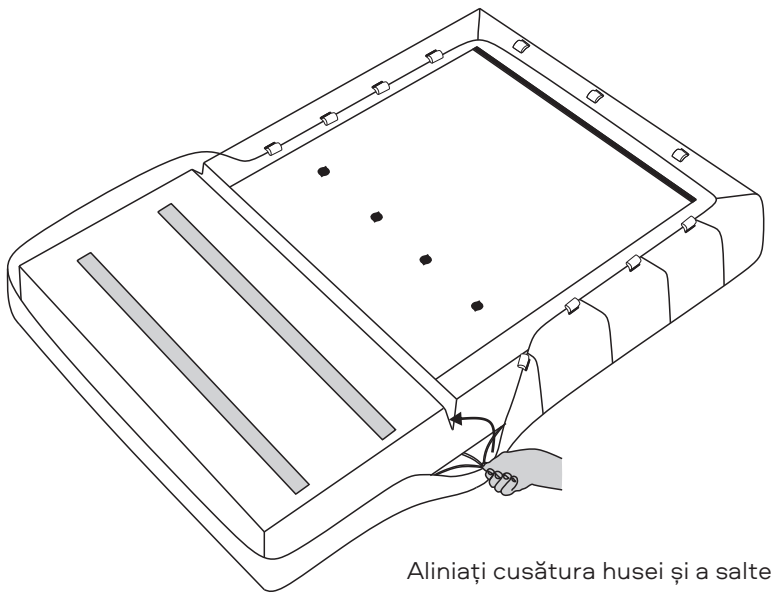

Aliniați cusătura husei și a saltelei.

18)

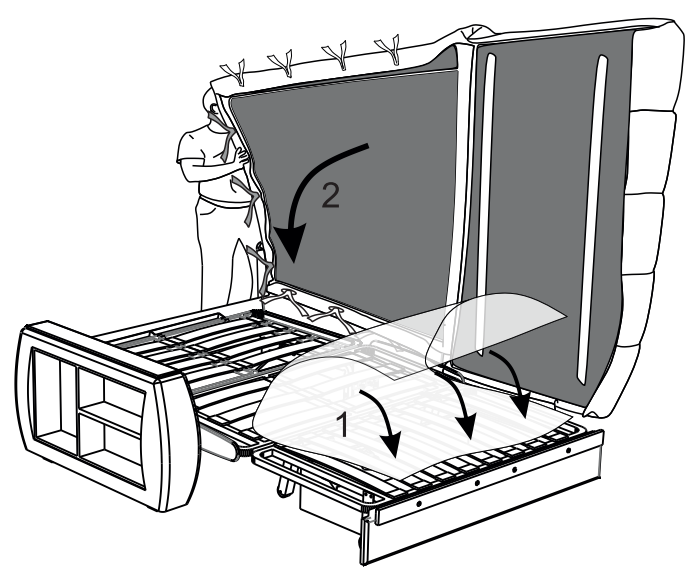

19)

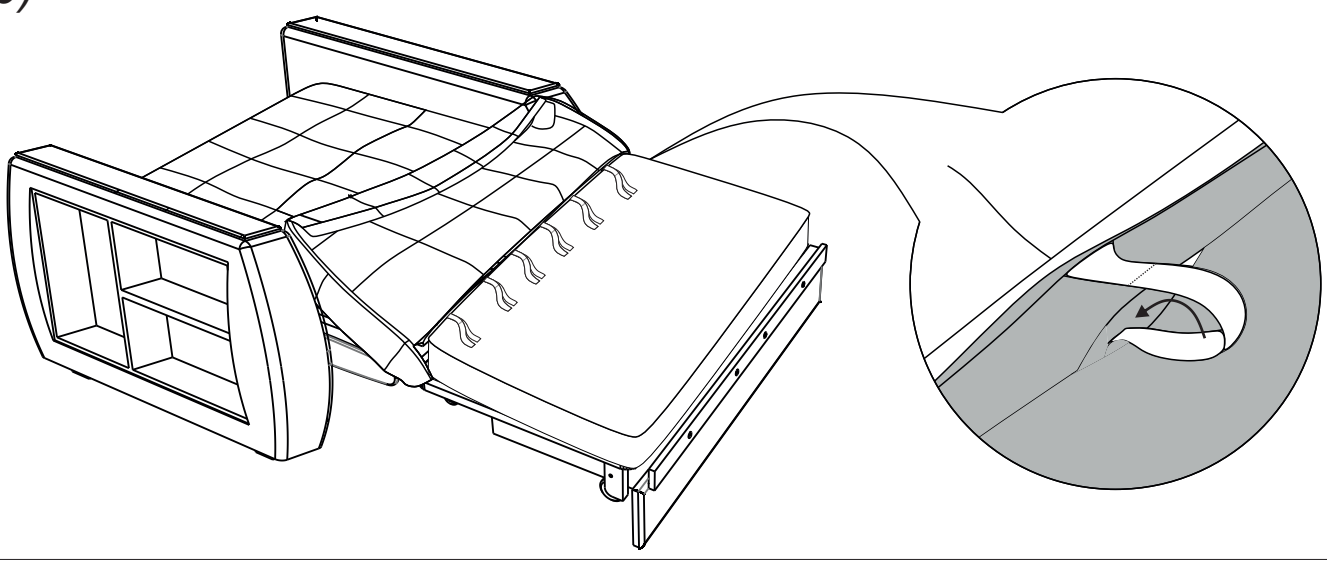

20)

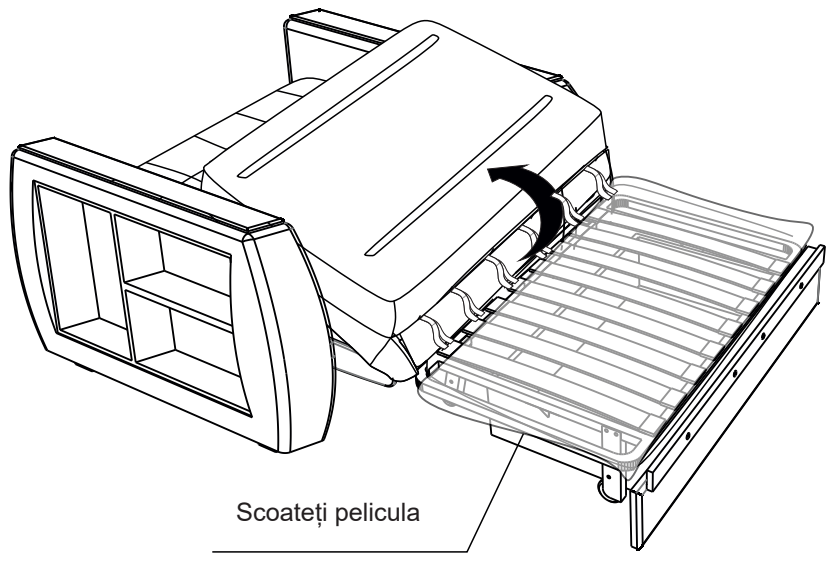

Scoateți pelicula

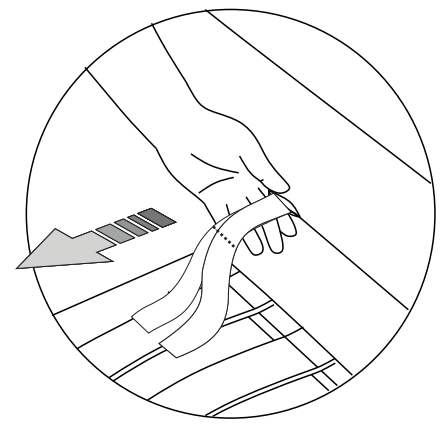

21)

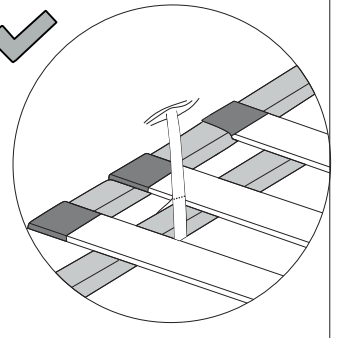
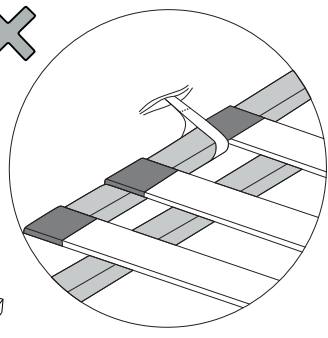
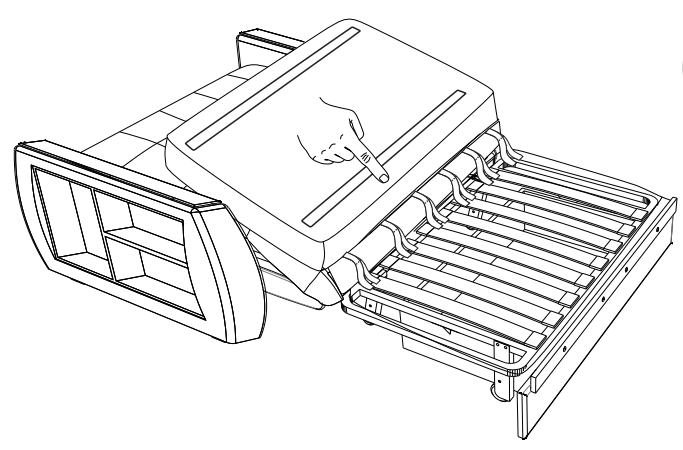

Agățați benzile de contact, trăgând strâns până la linia de cusătură.

22)

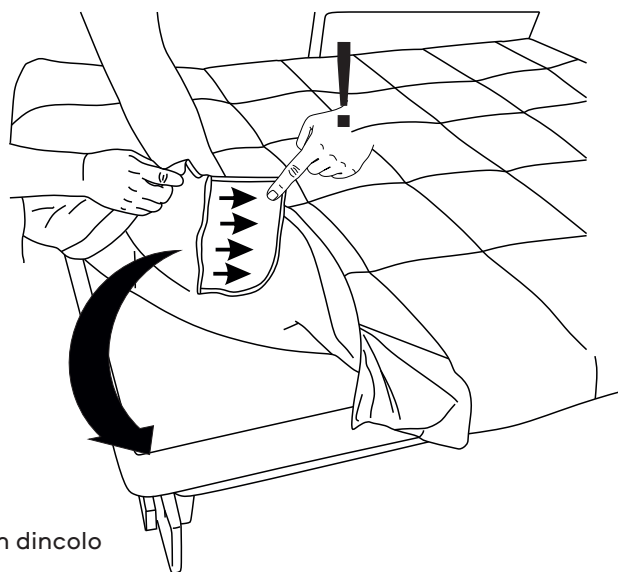
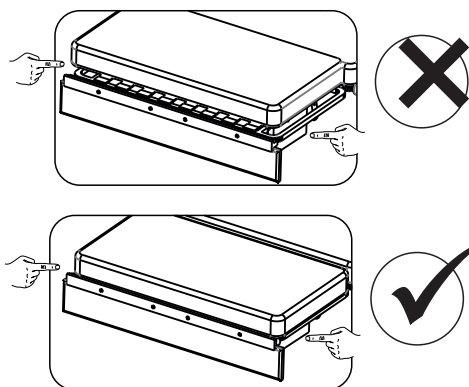

Salteaua nu trebuie să depășească mai mult de 1 cm dincolo de marginea lamelei.

23)

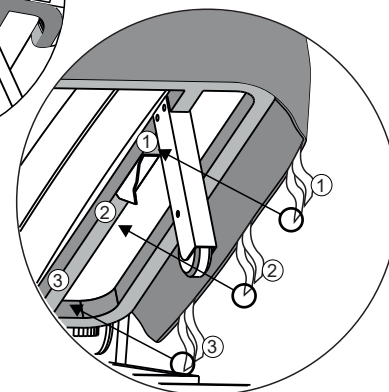
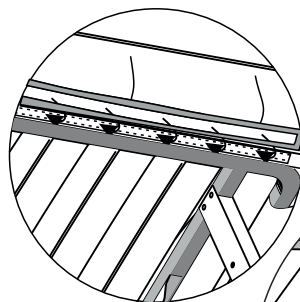
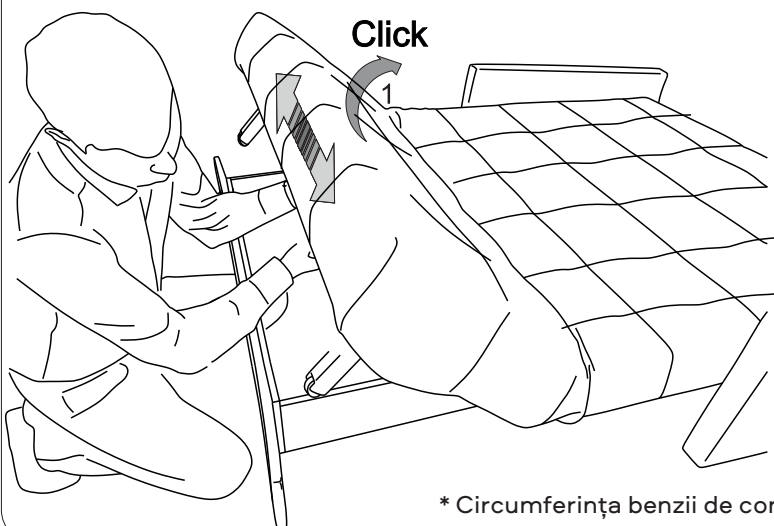

\* Circumferința benzii de contact — inel compl

24)

Strângeți excesul de husă de la piul saltelei pentru o transformare mai ușoară

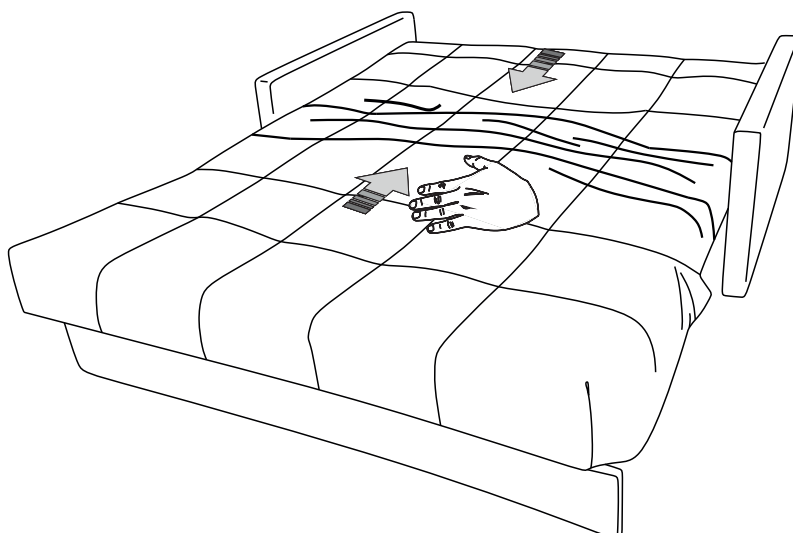

25)

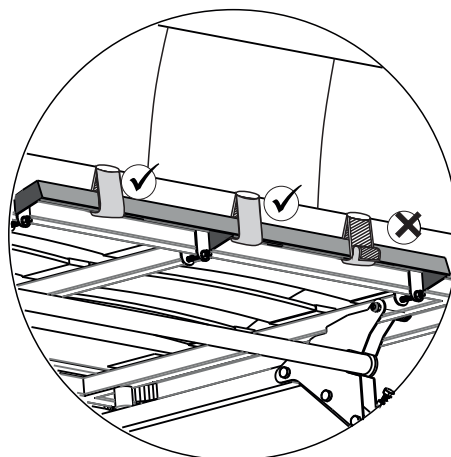
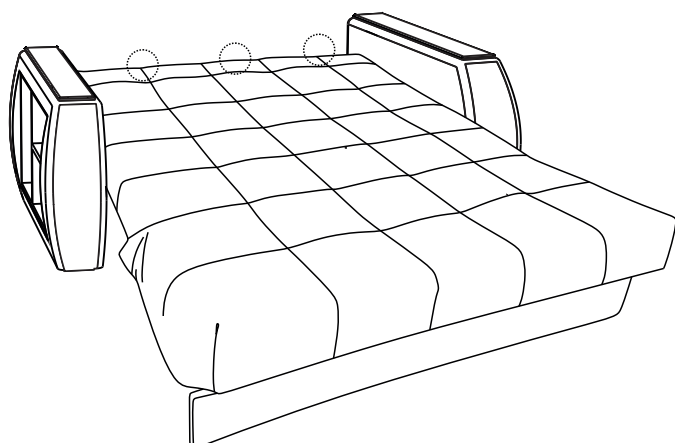

26)

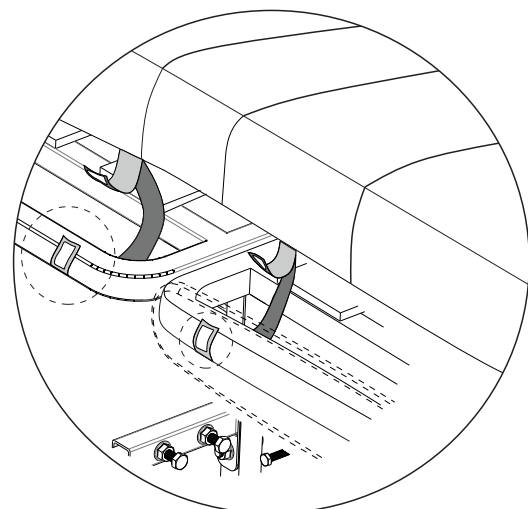
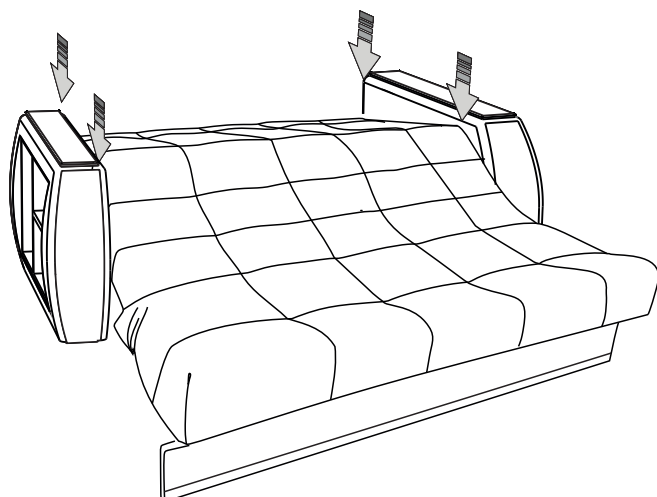

Mutați canapeaua într-o poziție semi-așezată.  
În timpul fixării benzile de contact trebuie să fie cât mai strânse posibil.

27)

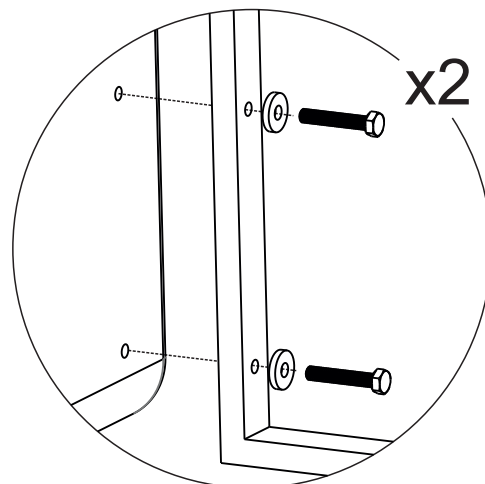
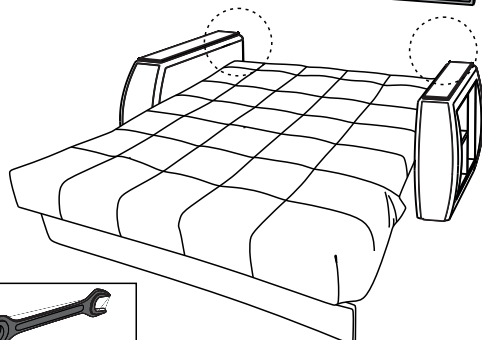
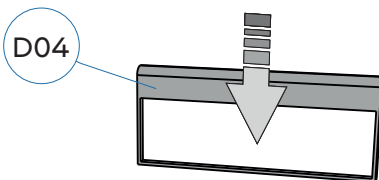

DF42

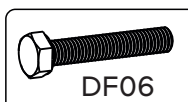

DF06

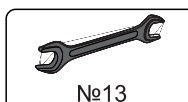

№13

28)

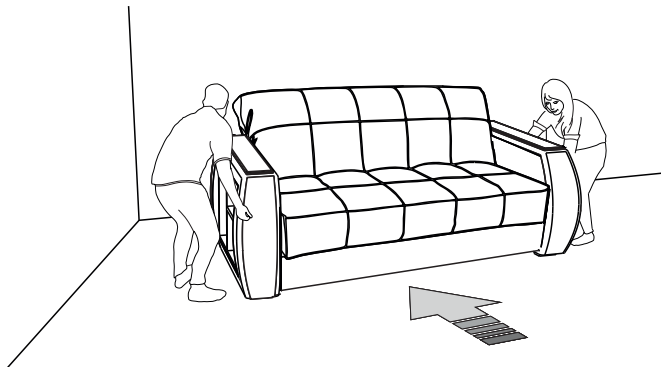

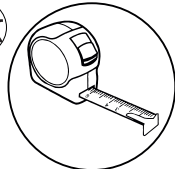
$A \approx B$  <sup>OK</sup> 

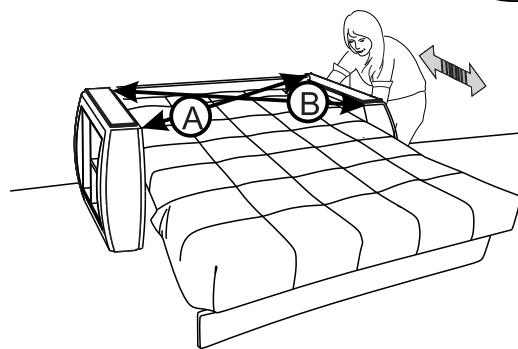

Instalați canapeaua într-un loc de utilizare permanentă

29)

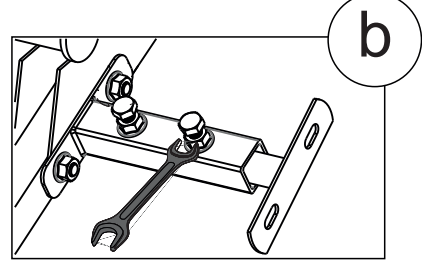
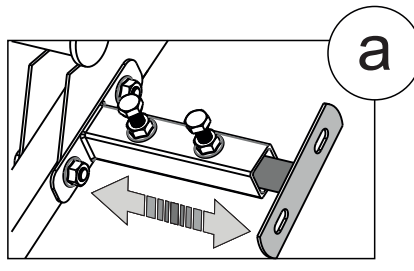
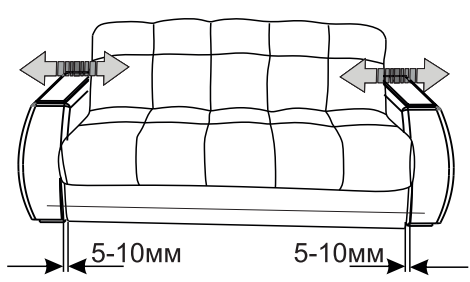

Strângeți strâns!

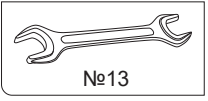

№13

30)

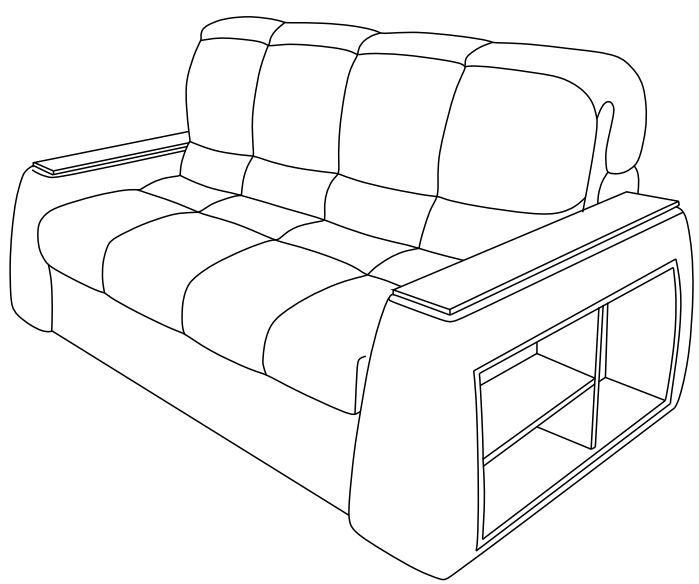

Asamblarea canapelei de colț

31)

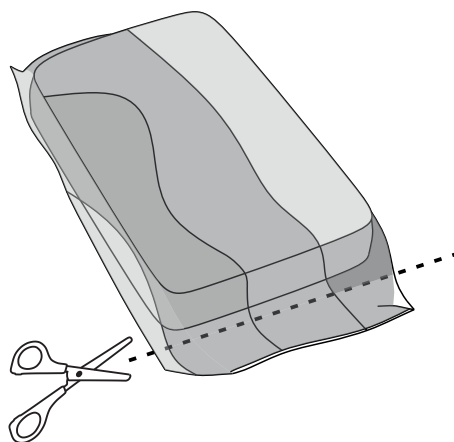
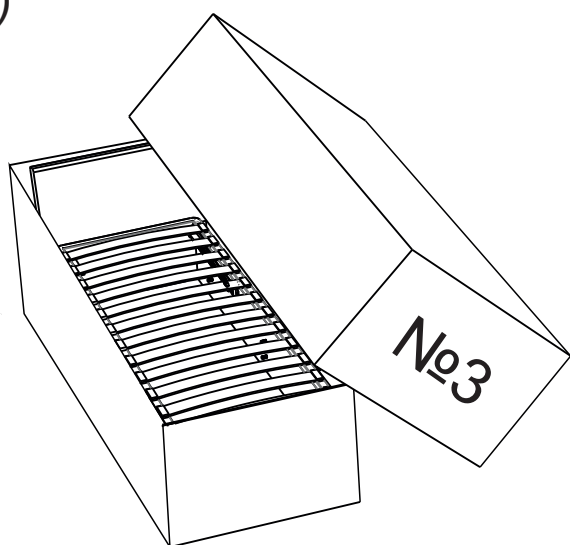

32

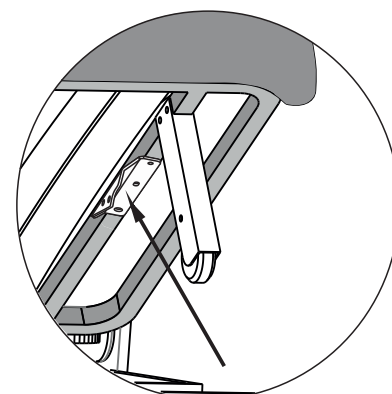
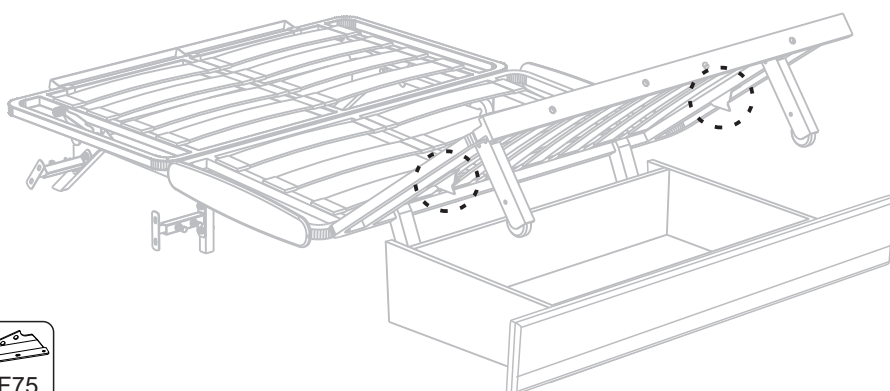

33)

Arcurile se instalează numai pe canapea mică

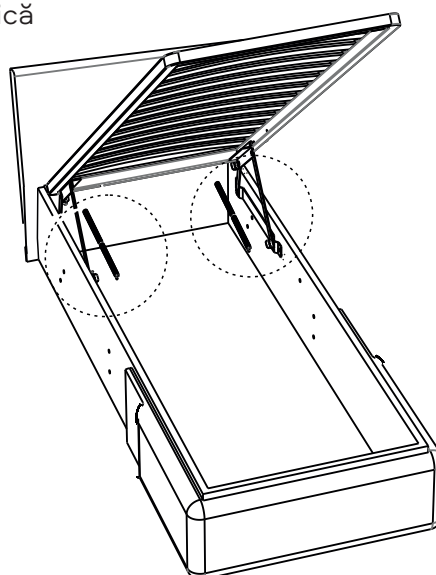
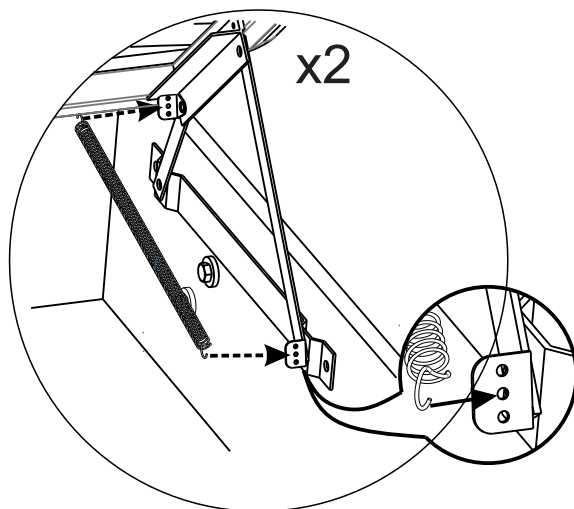



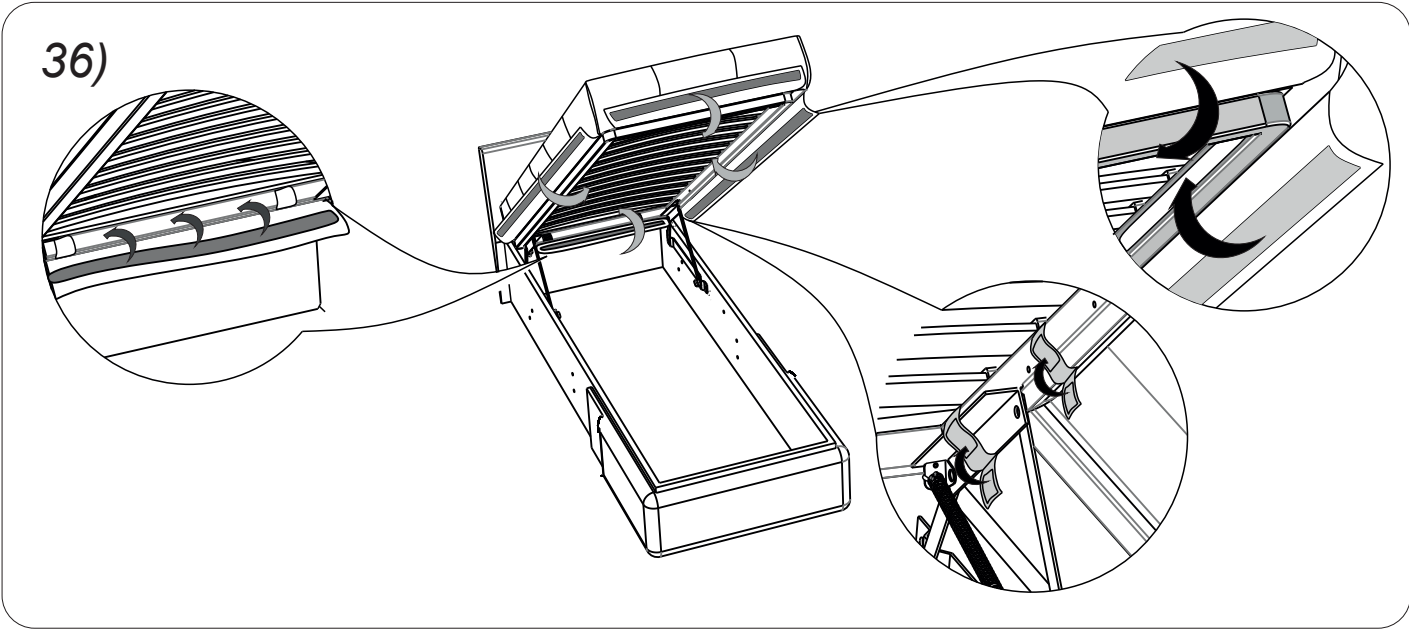
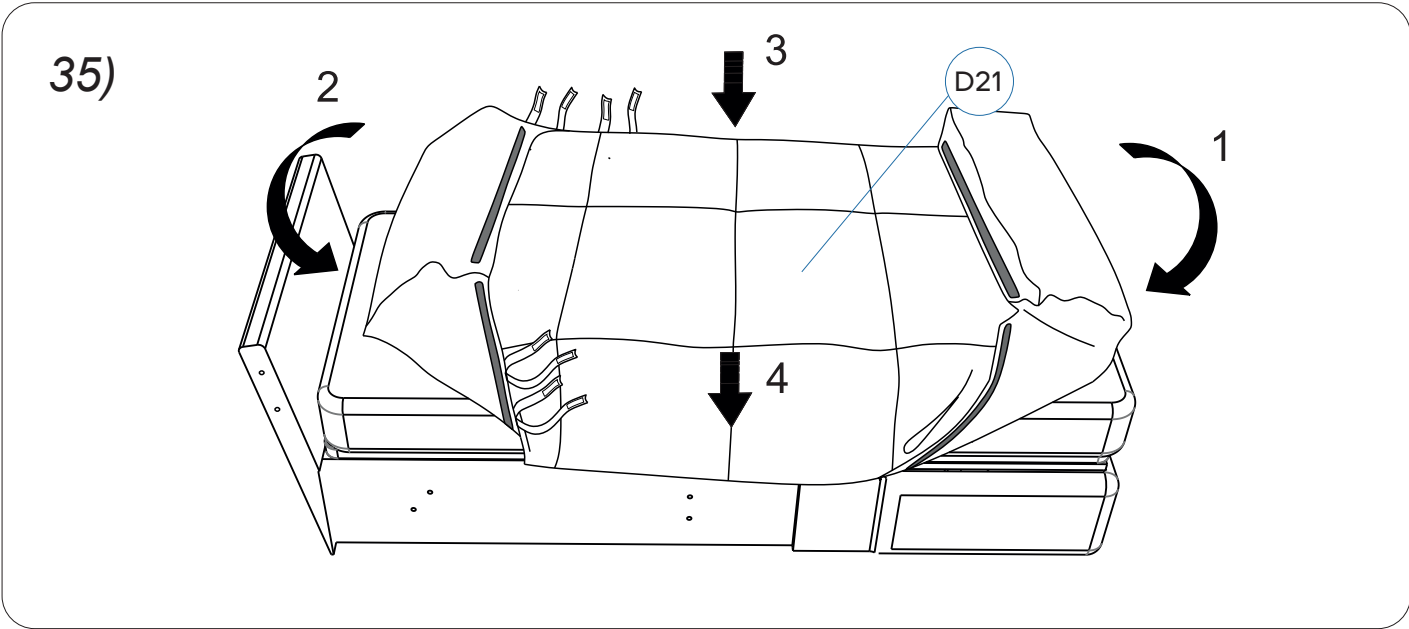
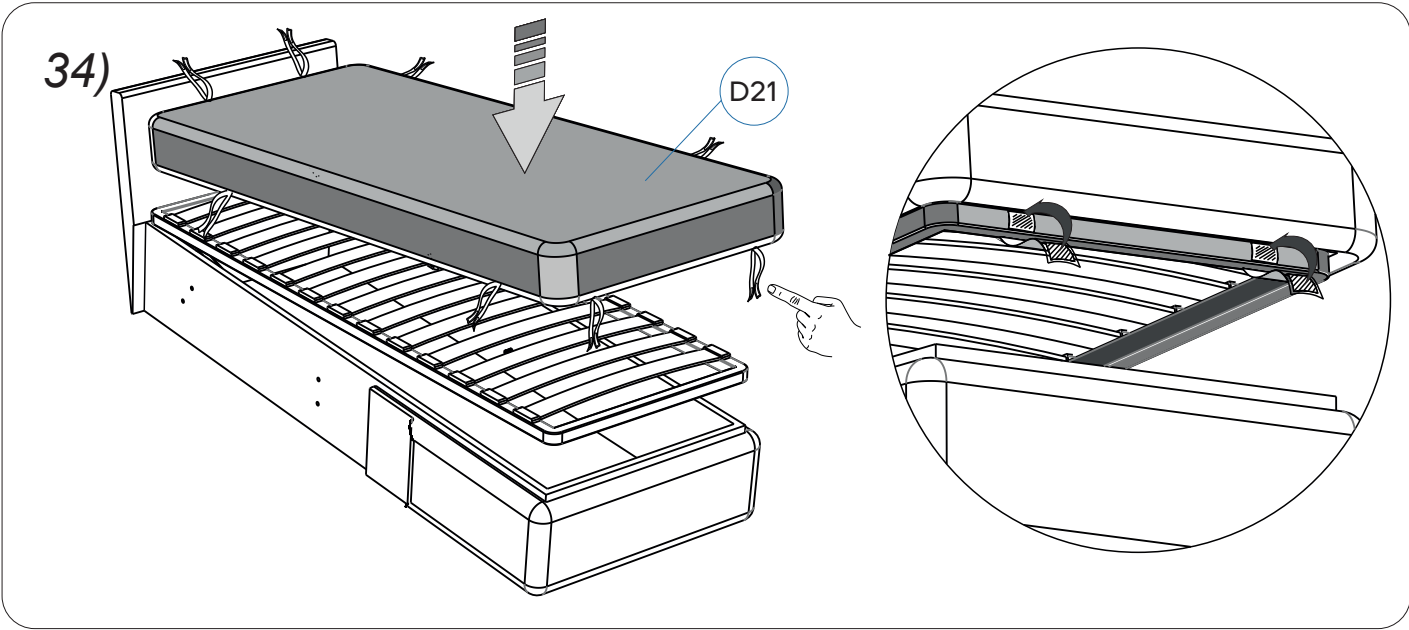



37)

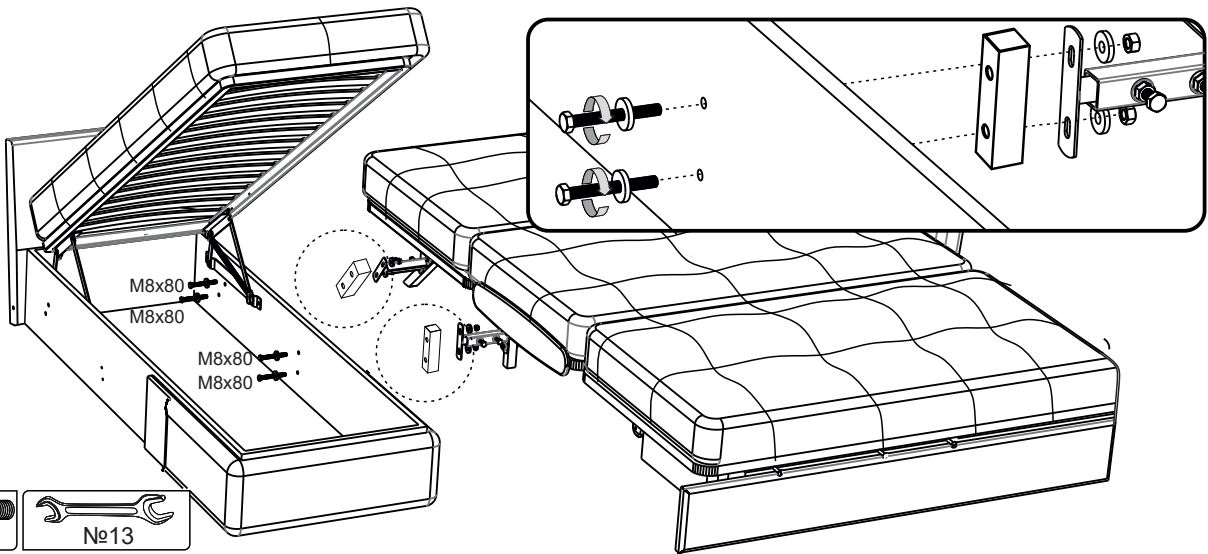

38)

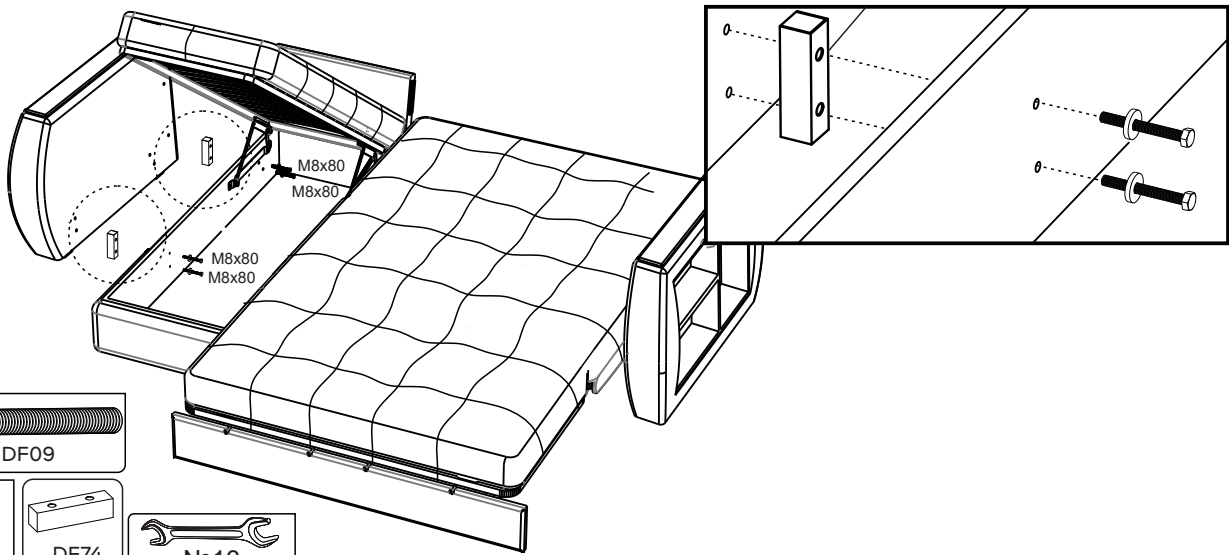

39)

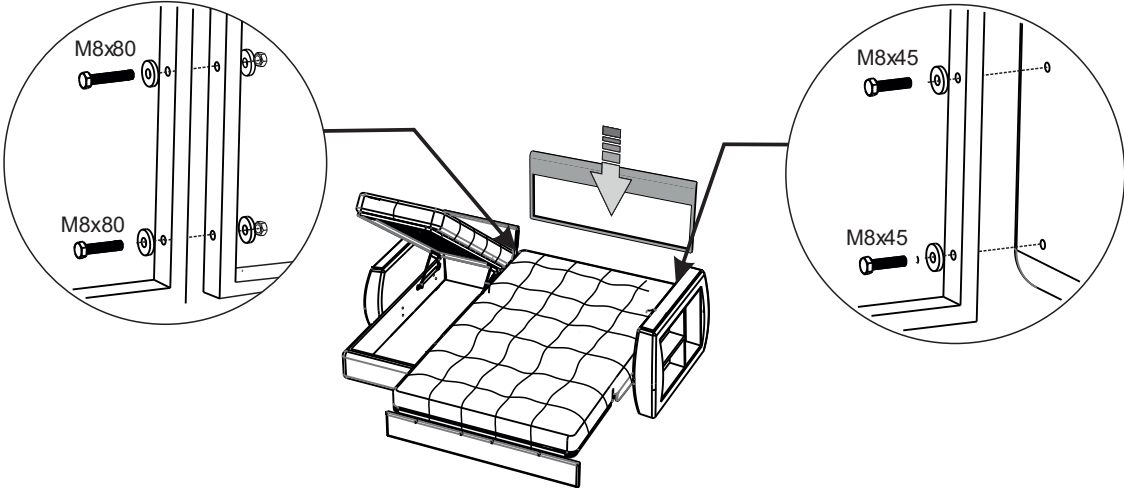

40)

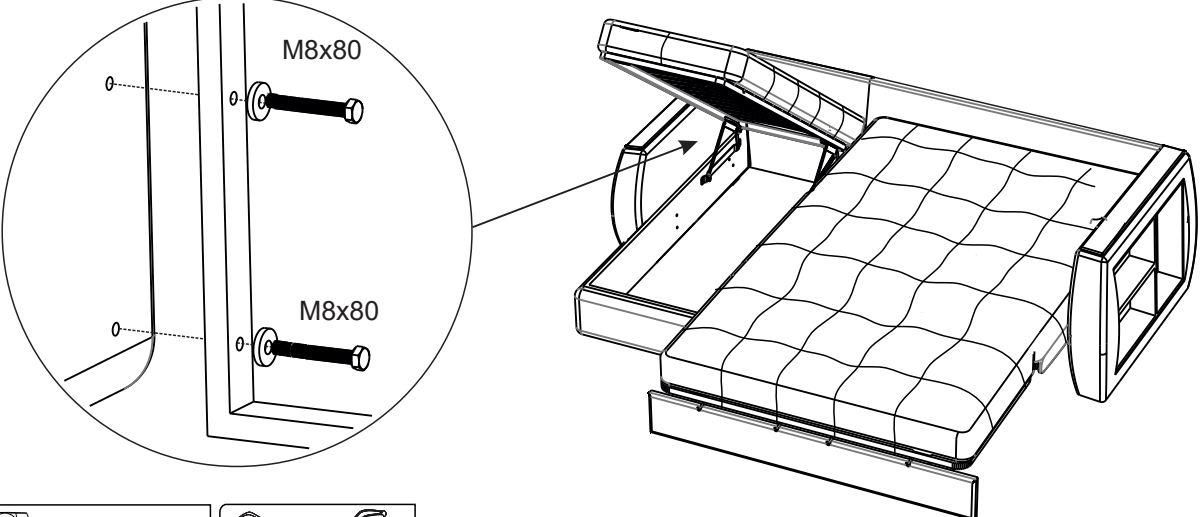

M8x80

M8x80

DF42

DF09

№13

41)

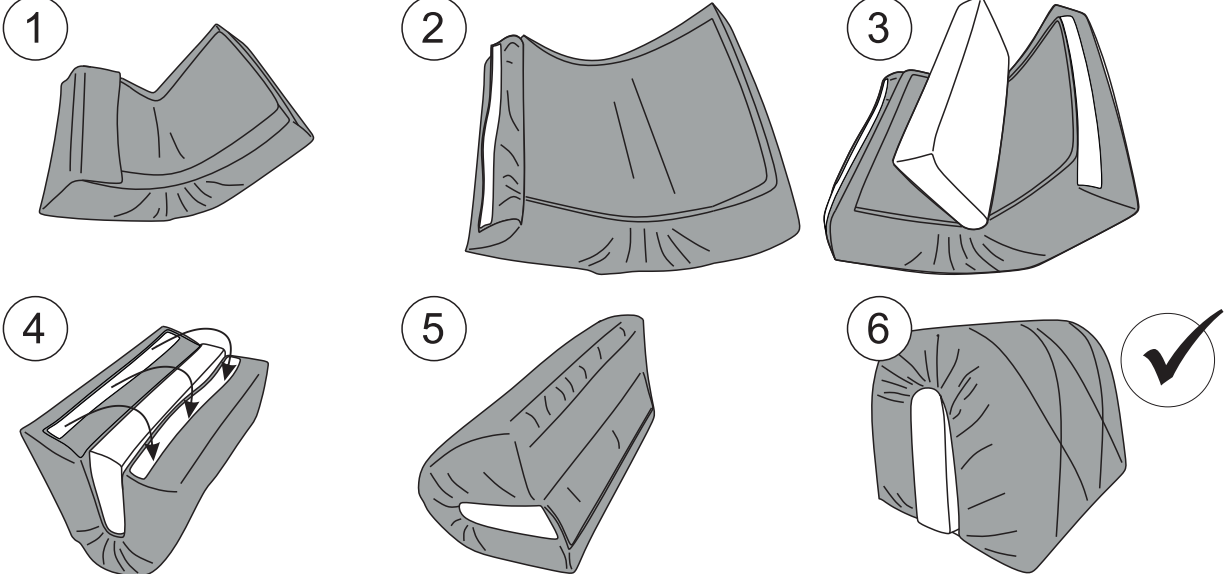

1

2

3

4

5

6

42)

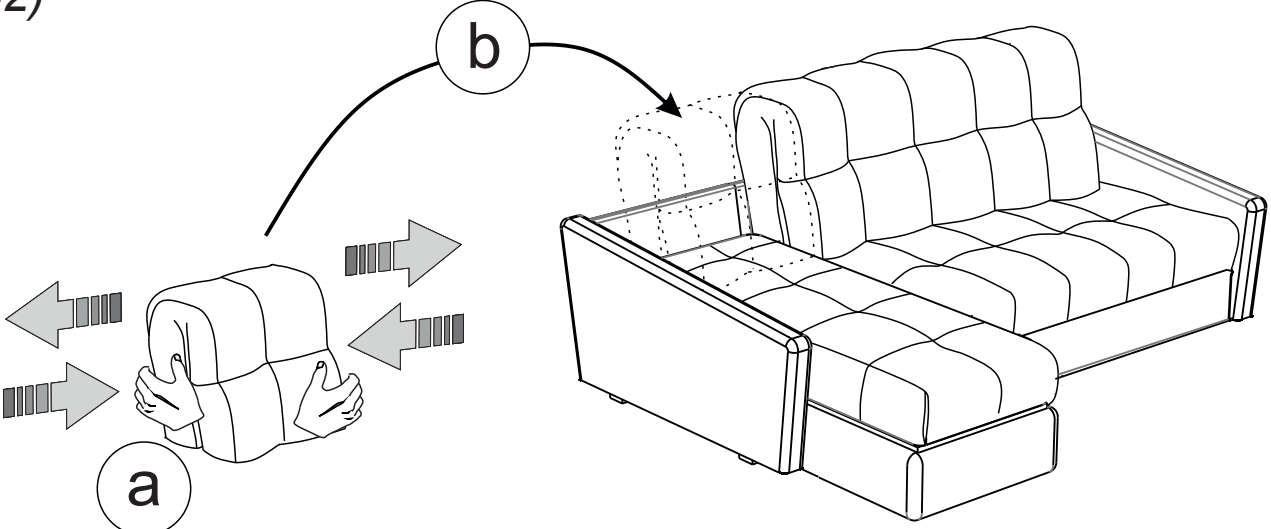

a

b

43)

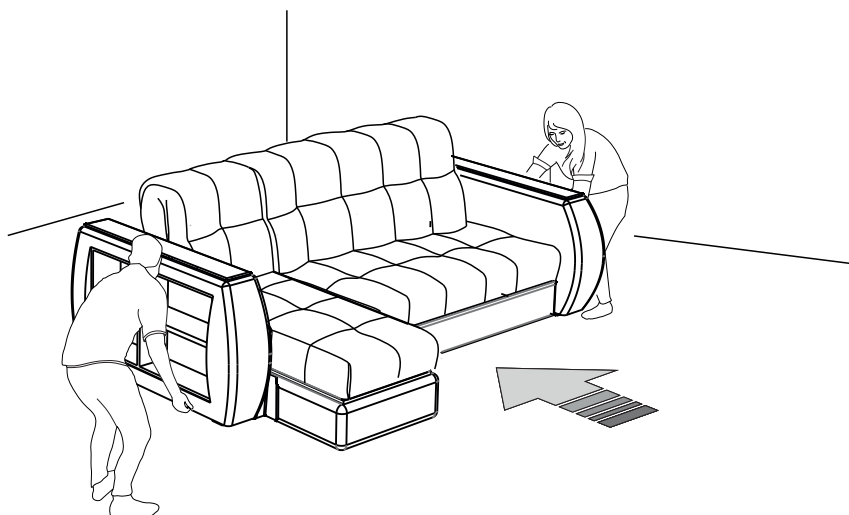

Instalați canapeaua într-un loc de utilizare permanentă

44)

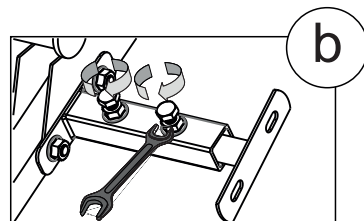
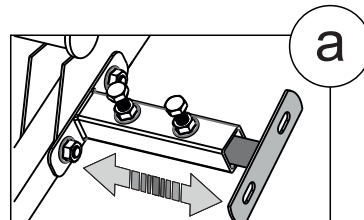
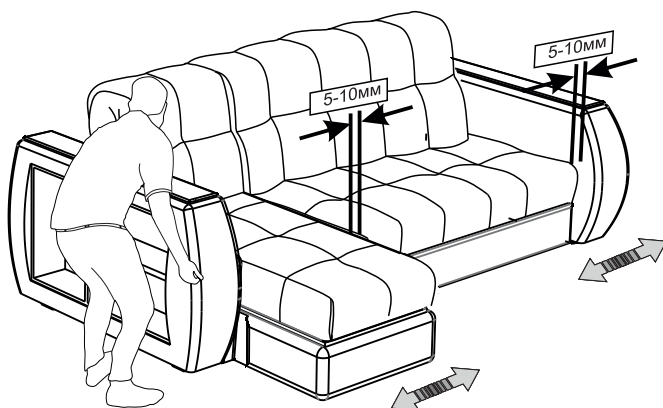

Strângeți strâns!



45)

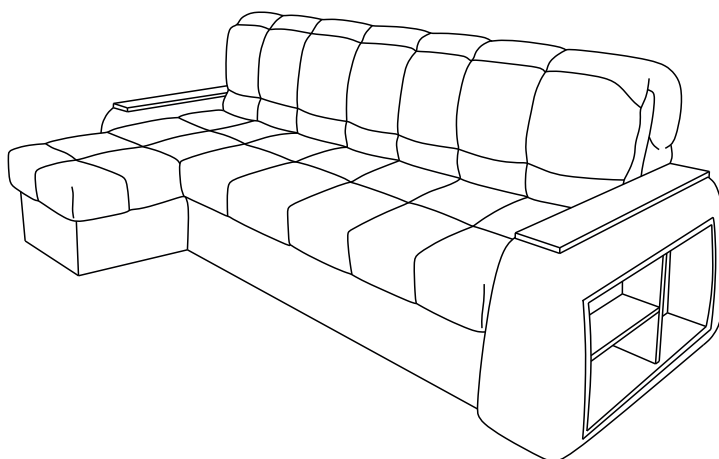

Procedura de transformare a canapelei

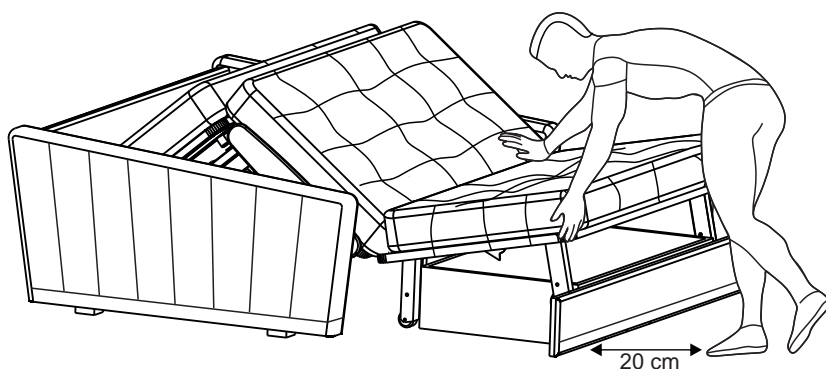
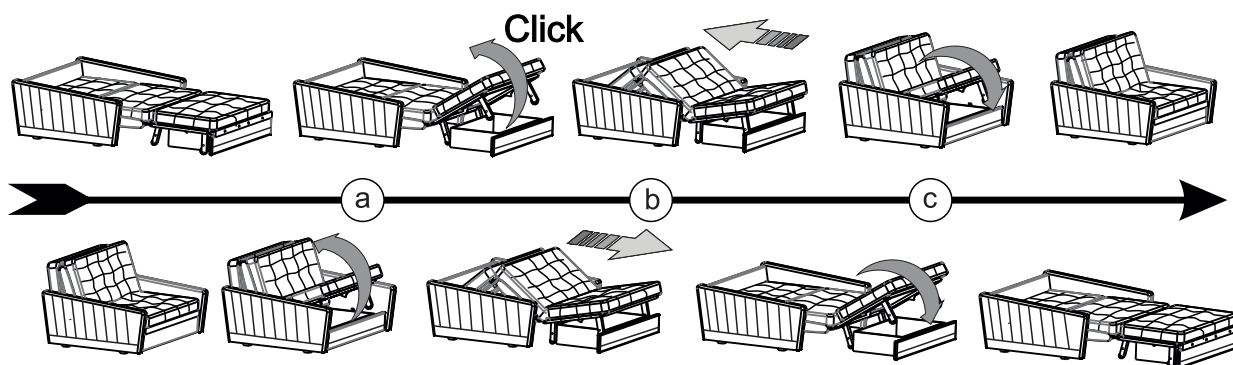

Dacă scaunul canapelei nu se ridică, desfaceți patch-urile velcro de transportare.

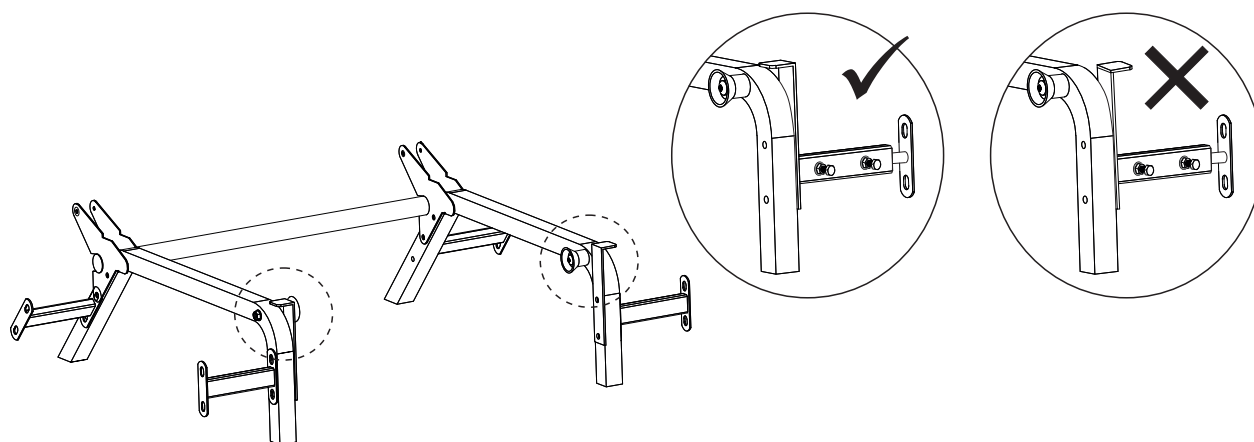

Dacă fundul canapelei nu se mișcă, verificați poziția suporturilor pe mecanism.

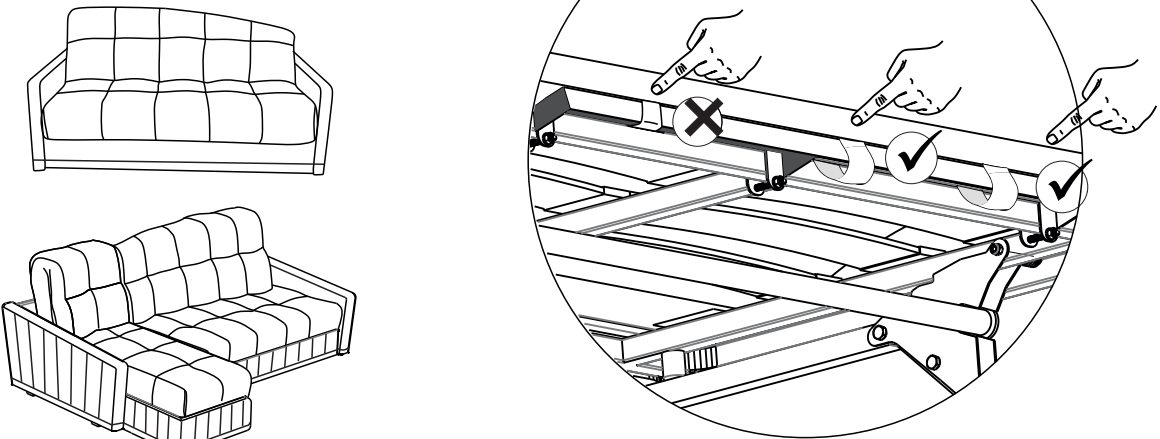

Dacă spatele este înclinat, slăbiți benzile de contact de la tăblie

Dacă există un spațiu mare între saltea și cotieră, ridicați zona fundului și slăbiți benzile de contact

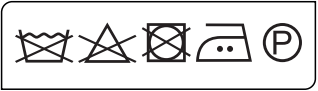
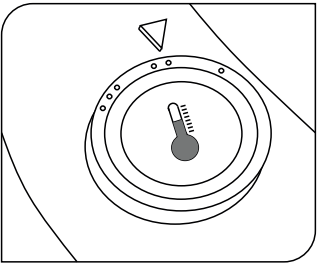
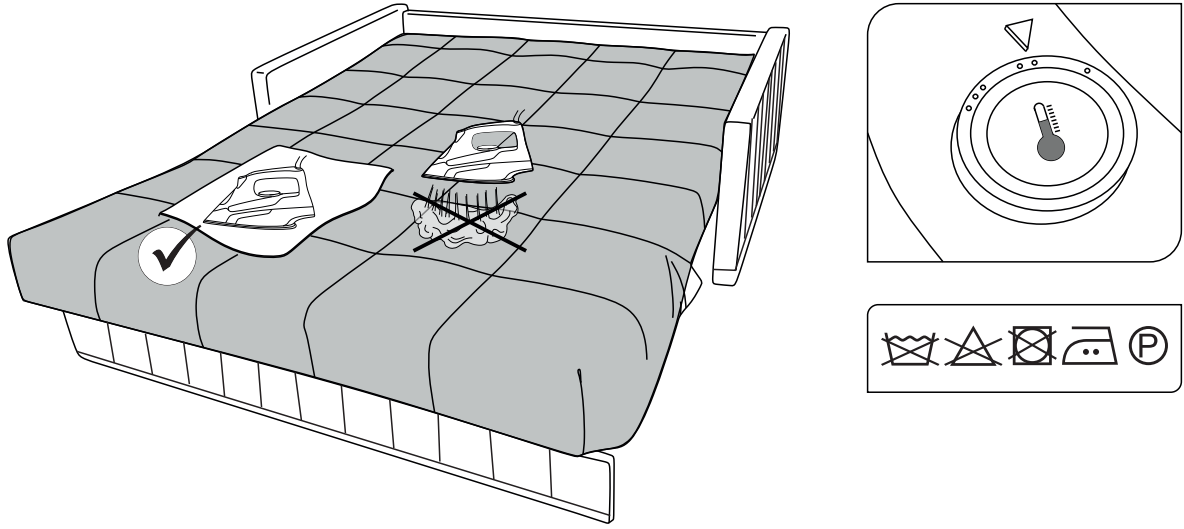
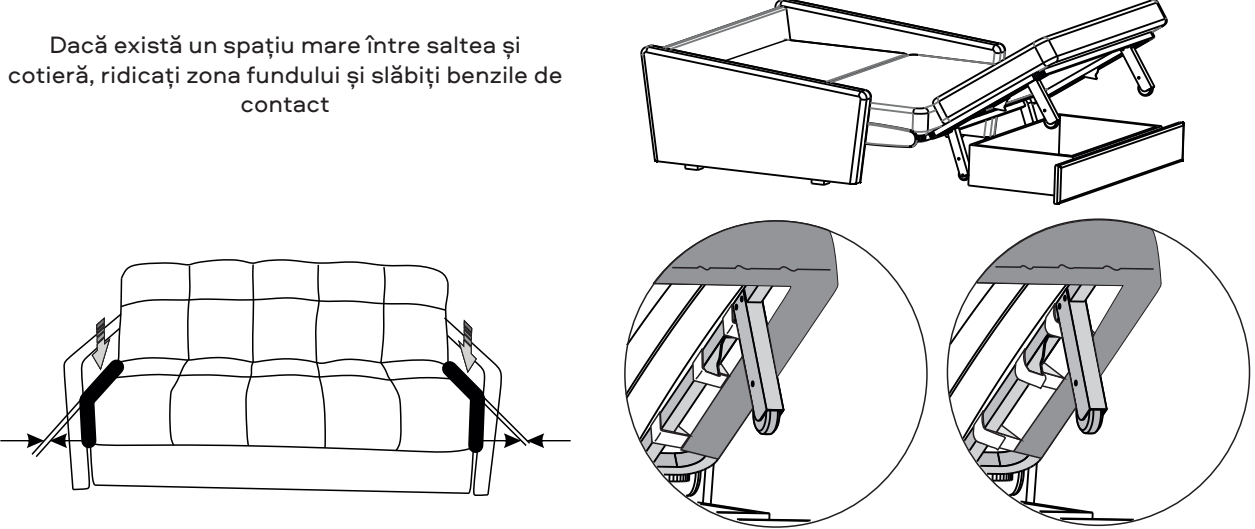

⊠ △ ⊠ ◻ ⊕

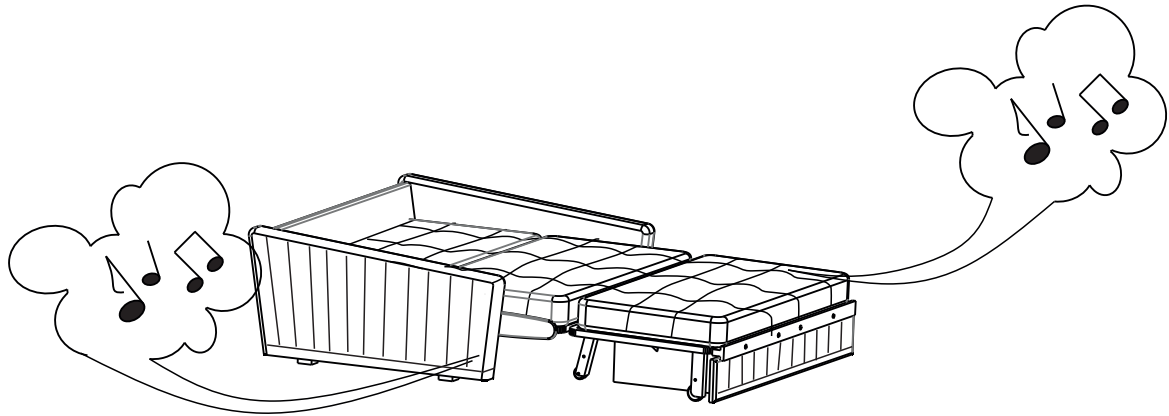

Țineți minte: Scârțâitul caracteristic al elementelor metalice ale mecanismului în timpul transformării constante este o situație normală. Canapeaua se bazează pe o structură metalică fiabilă, care vă permite să transformați canapeaua într-un pat în fiecare zi. În timpul transformării și funcționării lubrifianțul dintre diferitele noduri ale mecanismului se poate usca și apare frecarea elementelor metalice unele de altele. Pentru a evita această frecare și scârțâitul mecanismului în timpul transformării sau funcționării este important să respectați următoarele recomandări:  
Dacă apare un scârțâit, ungeți elementele de frecare ale mecanismului, strângeți conexiunile.  
Ungeți cel puțin o dată la 6 luni.

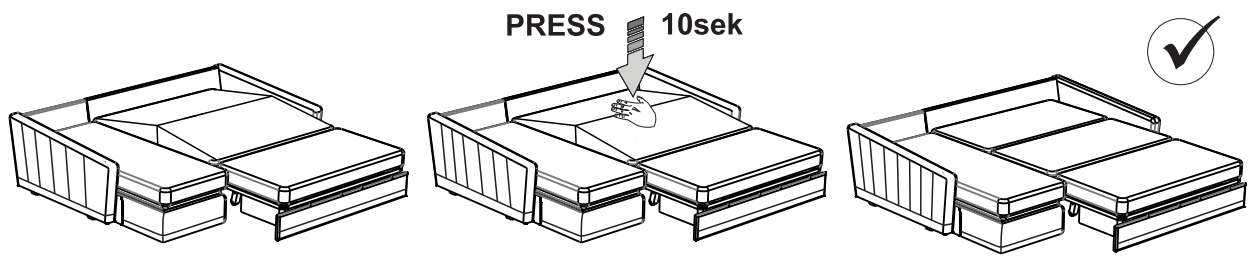
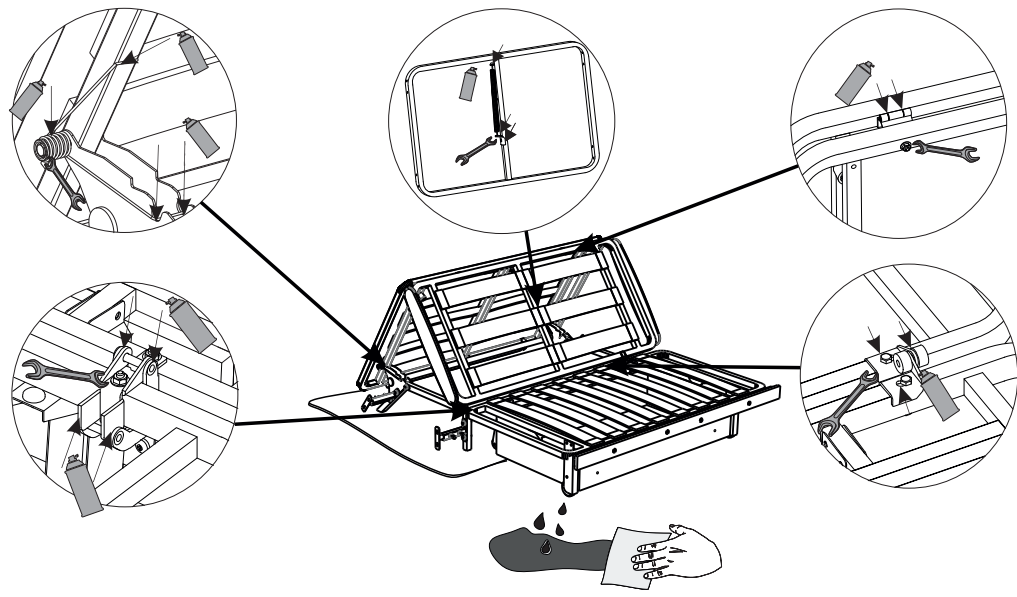
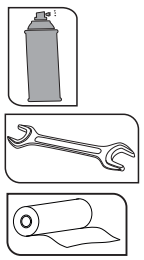



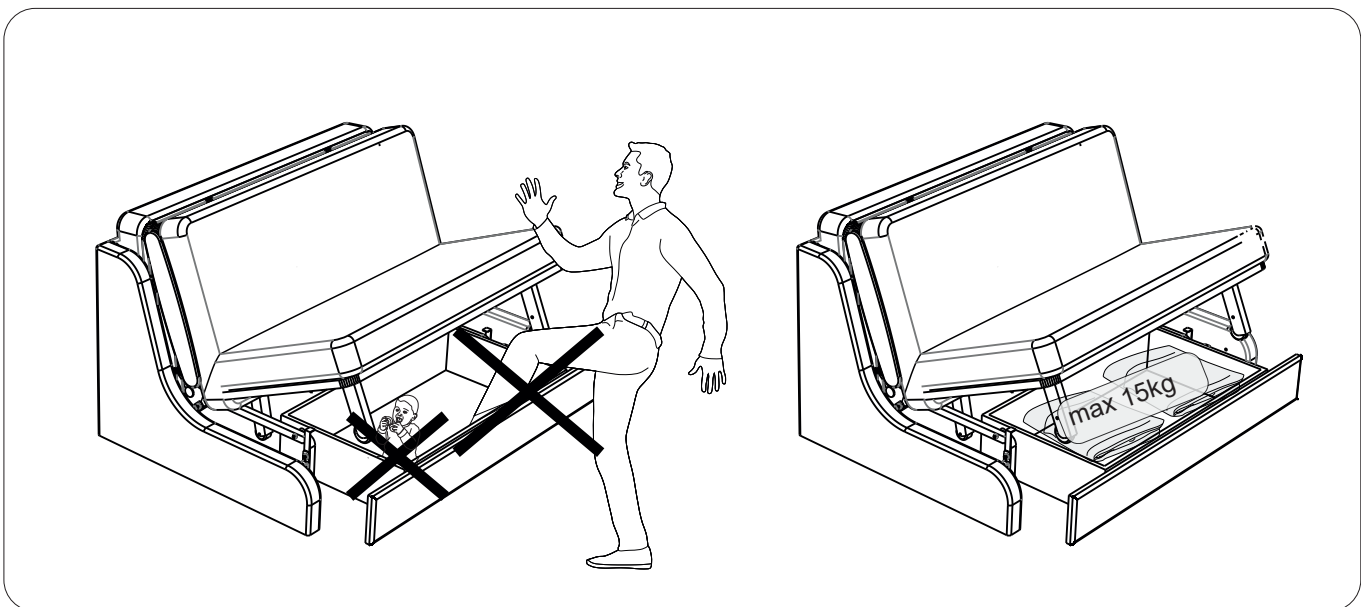
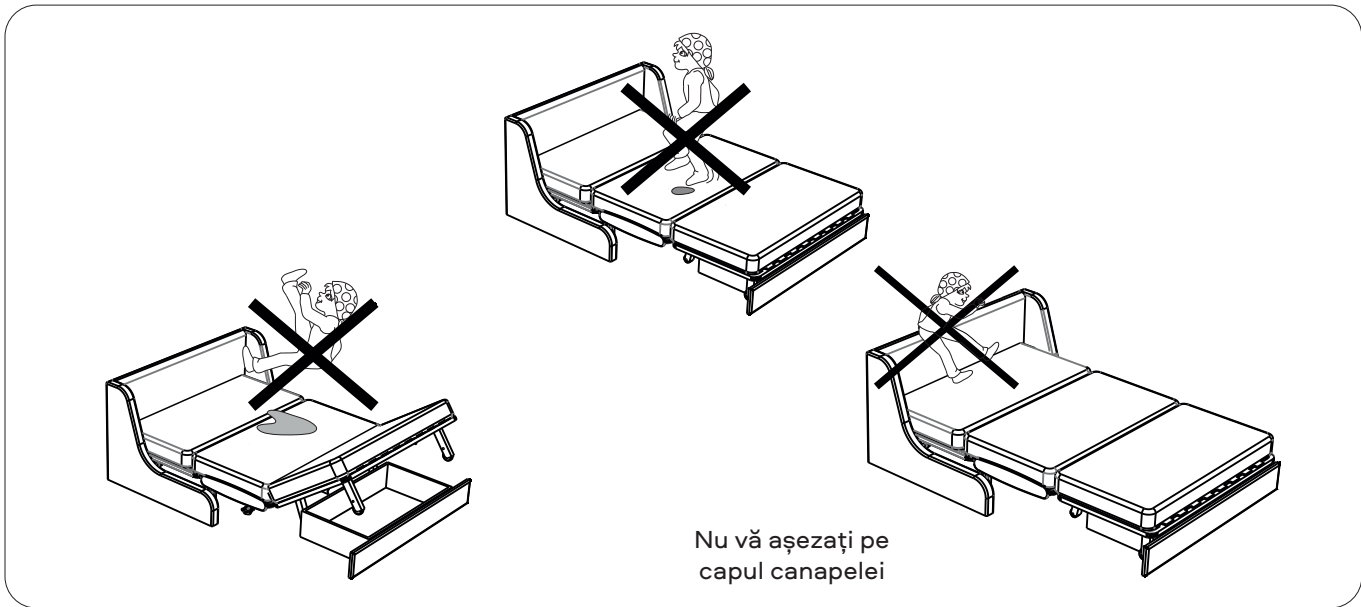
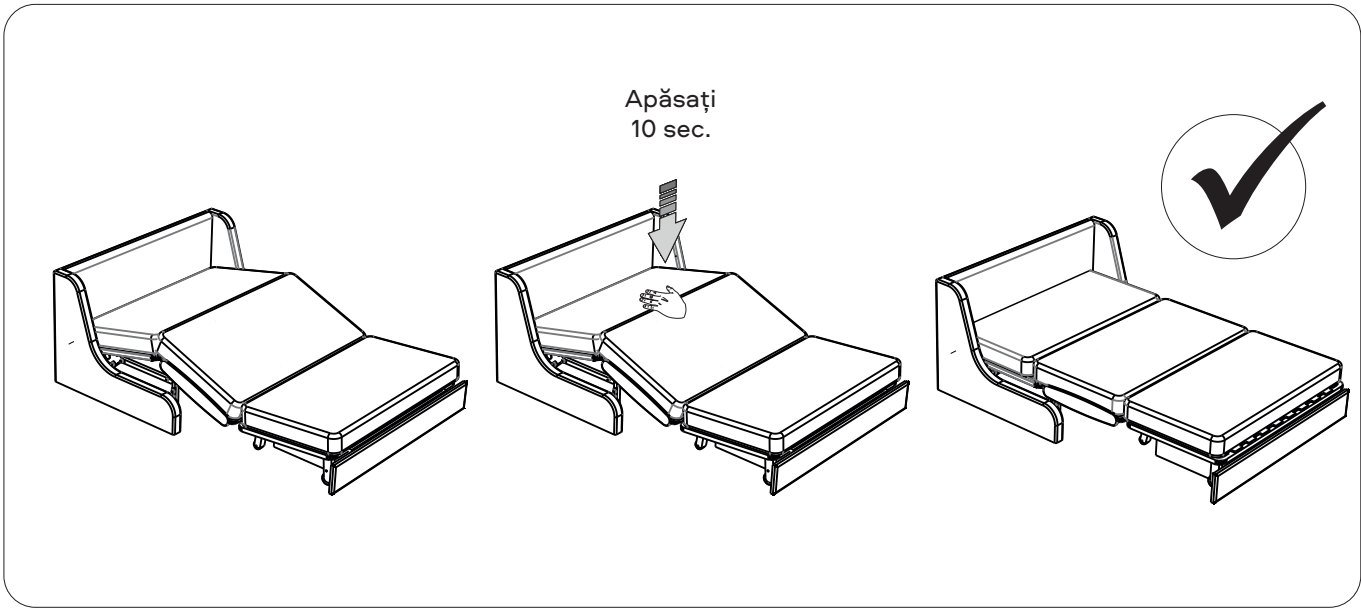







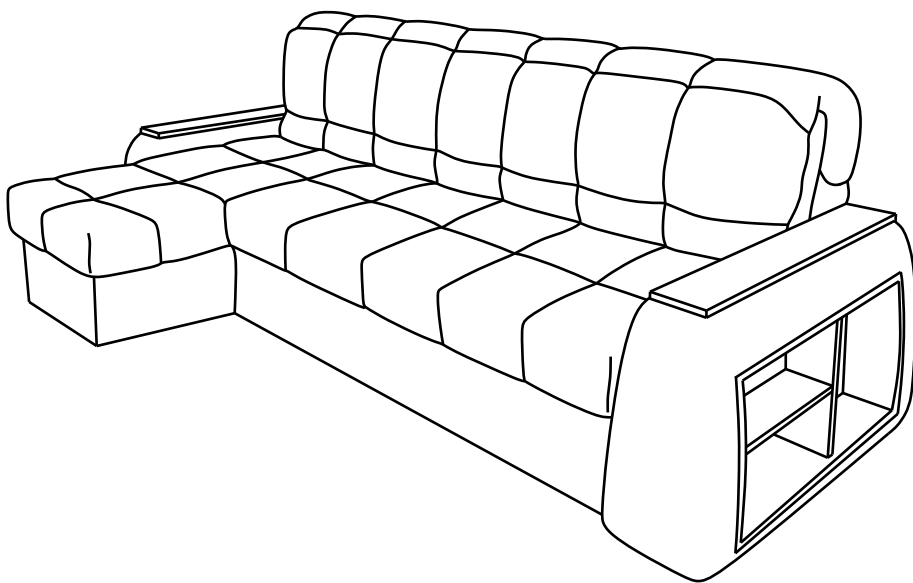
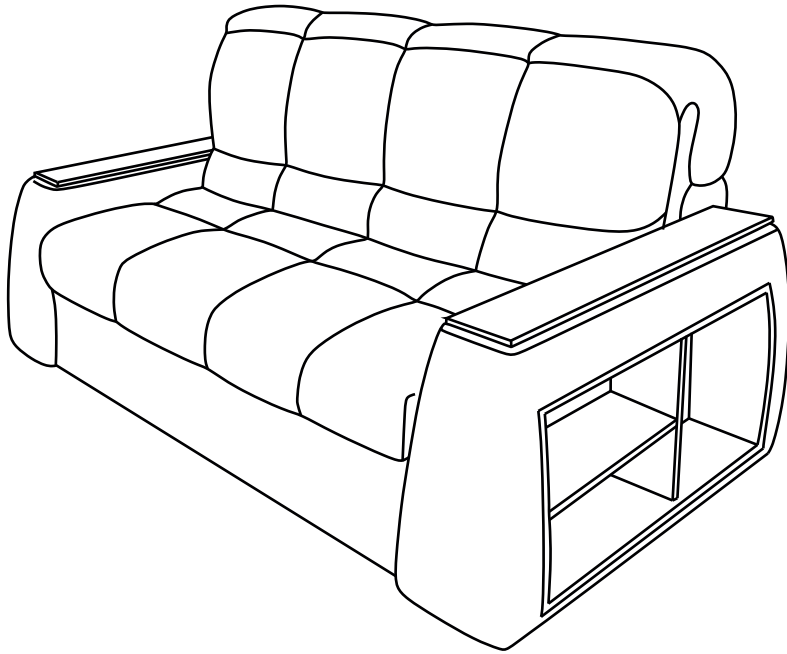



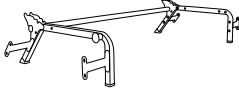

# SUNSET NOVA

FR



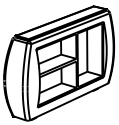
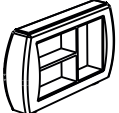

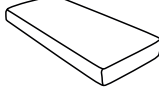

Sleep.8



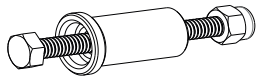
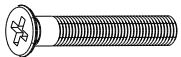

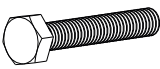
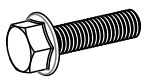
## Liste des pièces

Emballage	Pièce	Article	Désignation	Quantity
N° 1		D01	Mécanisme de transformation	1
		D26	Mécanisme de transformation support	1
		D04	Dossier	1
		D05	Cadre de base	1
		D07	Housse	1
			Notice d'assemblage	1
			Emballage avec accessoires	1
N° 2		D06	Accoudoirs	1
N° 3		D06	Accoudoirs	1
N° 4 Option supplémentaire		D14	Canapé	1
		D11	Canapé coussin	1
		D08	Housse	1
			Emballage avec accessoires	1
			Notice d'assemblage	1
Acheté séparément		D20	Matelas	1
		D21	Matelas de canapé	1

## Sofa

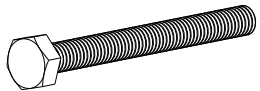
Package	Figure	Part marking	Name	Quantity
Emballage avec accessoires		DF02 DF15 DF16	Boulon M6x65 Manche en plastique Écrou	2
		DF11	Vis M6x30	3
		DF31	Ressort avec crochets	2
		DF06	Boulon M8x45	4
		DF56	Boulon M8x30	8
		DF42	Rondelle M8	4

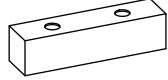

## Canapé

Package	Figure	Part marking	Name	Quantity
Emballage avec accessoires		DF30	Canapé printemps	2
		DF09	Boulon M8x80	10
		DF19	Écrou M8	6
		DF42	Rondelle M8	14
		DF74	Washer M8	4
		DF75	Arrêt du mécanisme	2

### Avant assemblage:

- 1. Vérifiez l'apparence et l'intégrité des pièces dans l'emballage!** Les réclamations pour dommages ne sont acceptées que pour les produits SANS traces d'assemblage.
- 2. Gardez l'emballage et la notice jusqu'à la fin d'assemblage!** Si, au cours du processus d'assemblage, un défaut et une incomplétude du produit sont détectés, il est nécessaire de garder l'emballage jusqu'à ce que le représentant de la société commerciale parte pour vous.
- 3. Vérifiez le nombre de pièces et d'accessoires selon la liste.** Le fabricant se réserve le droit d'apporter des modifications structurelles au produit, de remplacer les accessoires et les pièces métalliques par des éléments similaires qui n'aggravent pas l'apparence et n'affectent pas les propriétés fonctionnelles du produit. S'il est incomplet ou cassé, encerclez le numéro de pièce manquante et informez le magasin pour un remplacement.
- 4. Respectez l'ordre d'assemblage indiqué dans cette notice!** Si les instructions d'assemblage et notices d'utilisation ne sont pas suivies, la garantie du fabricant sera annulée.
- 5. Pour installer le canapé convertible, choisissez une zone plane du sol!** Si le sol est incurvé, ou s'il y a de grands tapis il peut y avoir des écarts dans le fonctionnement du mécanisme de transformation du canapé convertible, des distorsions de la forme du produit.
- 6. 2 personnes sont nécessaires pour l'assemblage du canapé convertible.** Déplacez toutes les pièces avec précaution, sans à-coups, empilez-les de la manière stable, ne les laissez pas tomber ou heurter !
- 7. Déplacez les meubles et les accessoires en les soulevant légèrement.** Cela permettra d'éviter la déformation et la casse.
- 8. Veuillez lubrifier le mécanisme de transformation lors de l'assemblage conformément aux instructions!** Cela va aider à éviter l'apparition de grincements prématurés. Répétez la lubrification, serrez les vis et les écrous visiblement desserrés au moins une fois tous les six mois.

### Pour assemblage il vous faut:

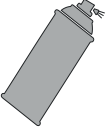
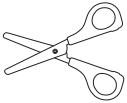
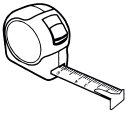
	Tournevis cruciforme
	Clé à fourche N°13 x 1 Clé à fourche N°10 x 2
	Serviette en papier
	Lubrifiant siliconé en spray
	Ciseaux
	Roulette d'arpenteur

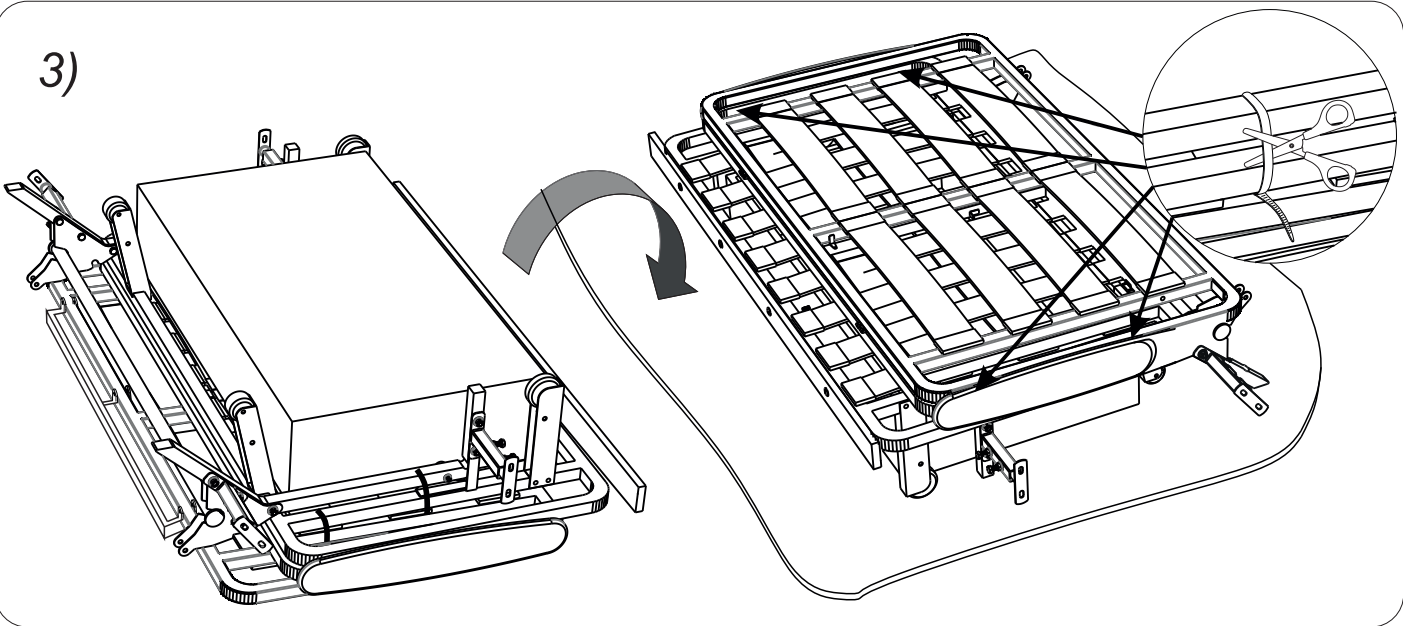
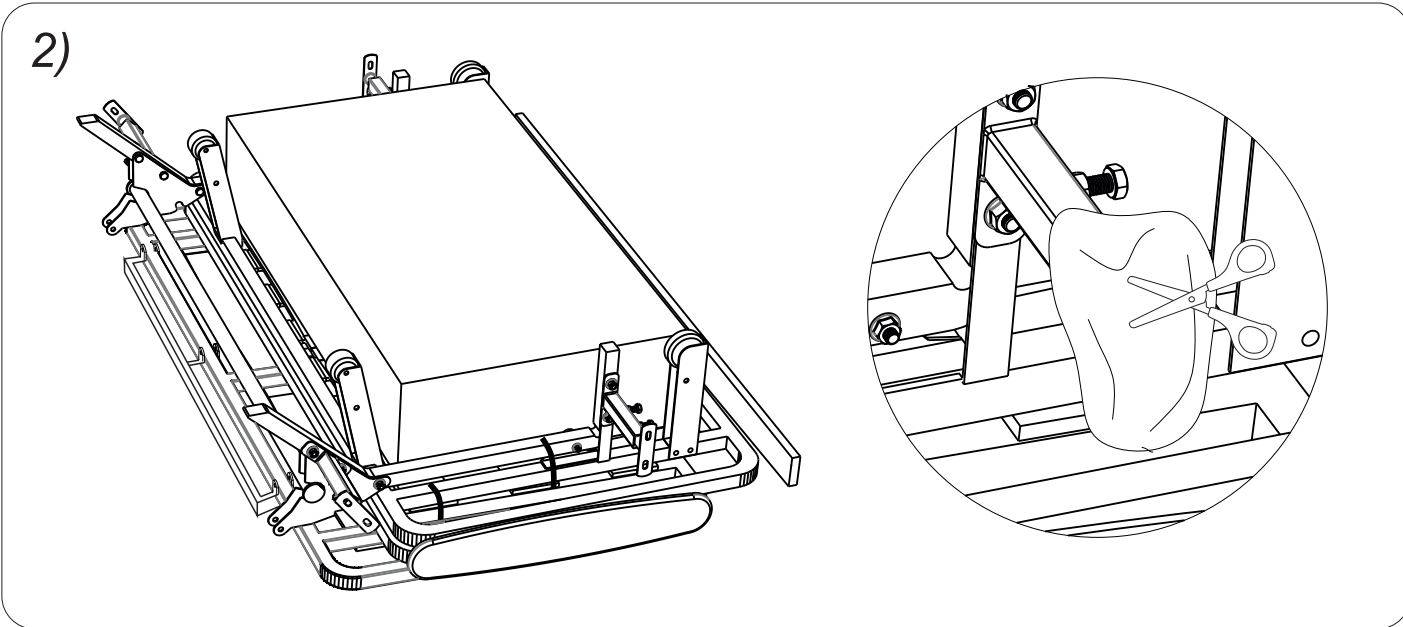
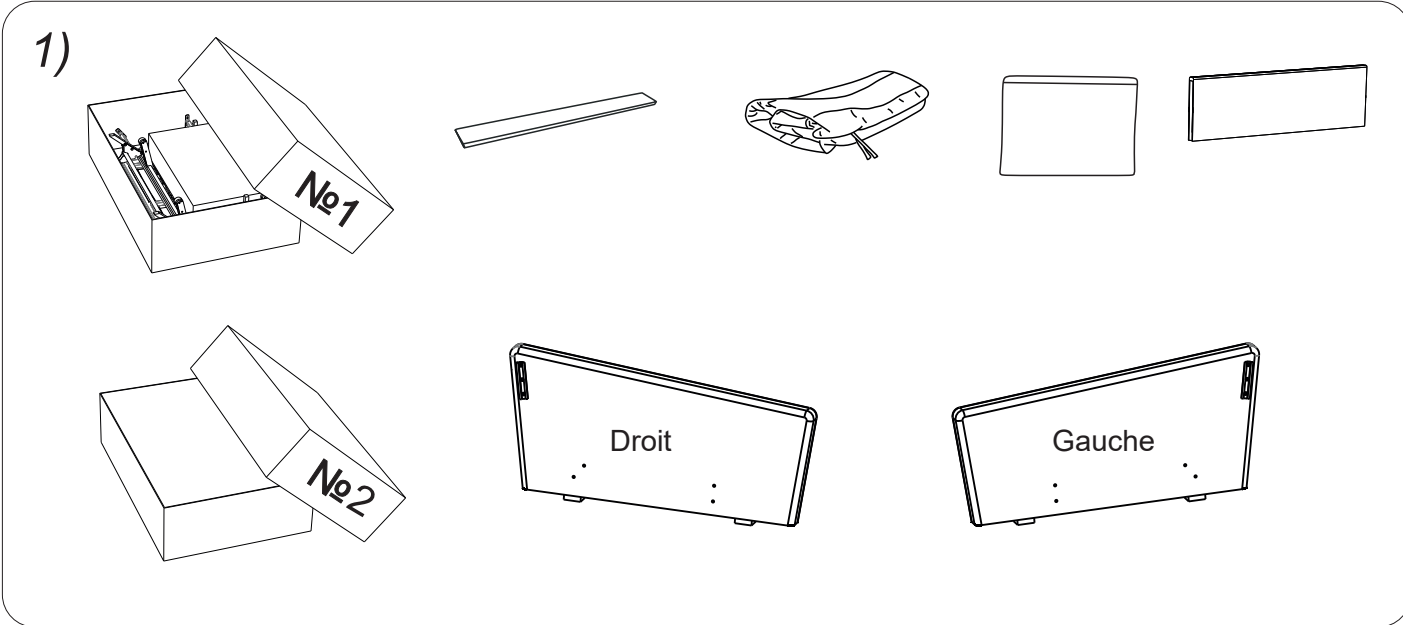

4)

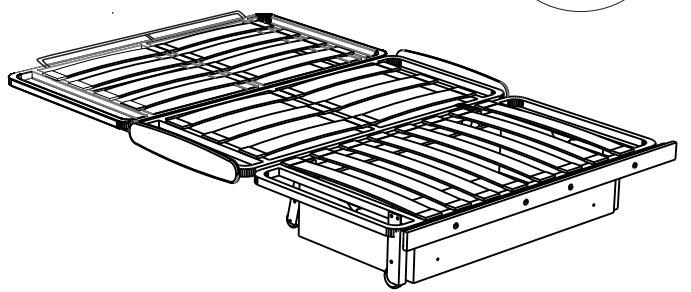
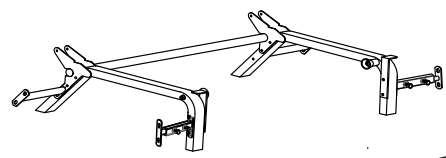
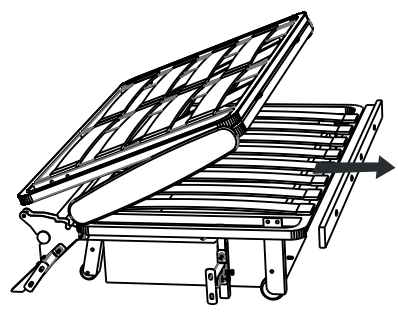

Retirez le cadre de la base

5)

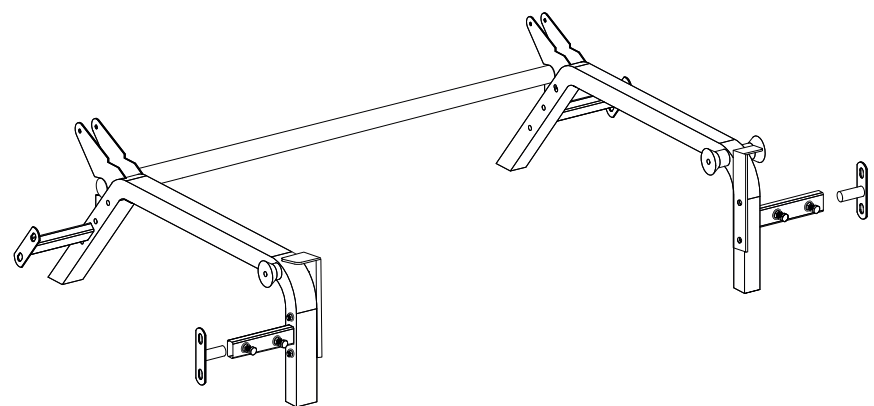
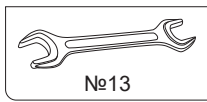
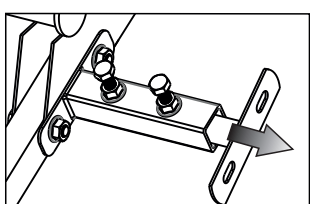
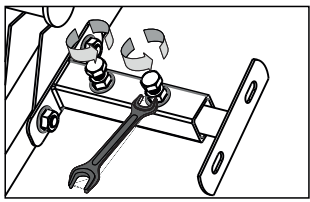

6)

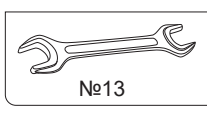
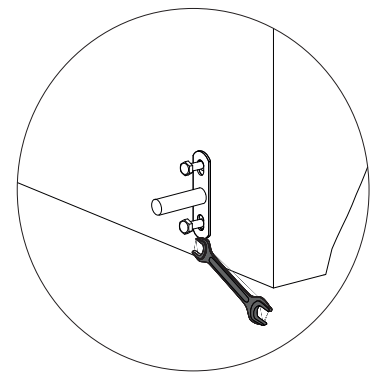
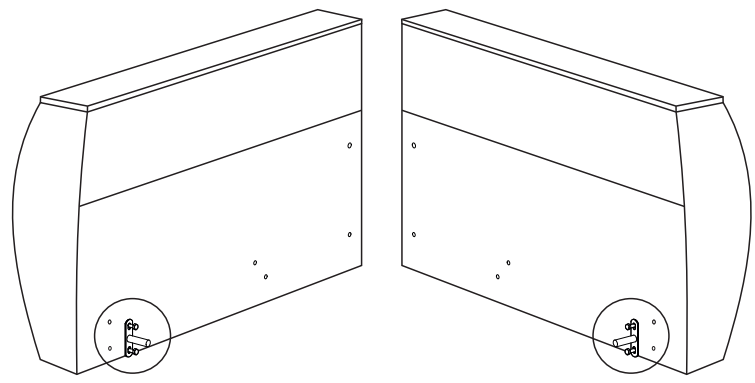

Lors de l'assemblage d'un canapé d'angle, installez le support sur un accoudoir (du côté opposé au canapé)

7)

Ne serrez pas les vis du support.

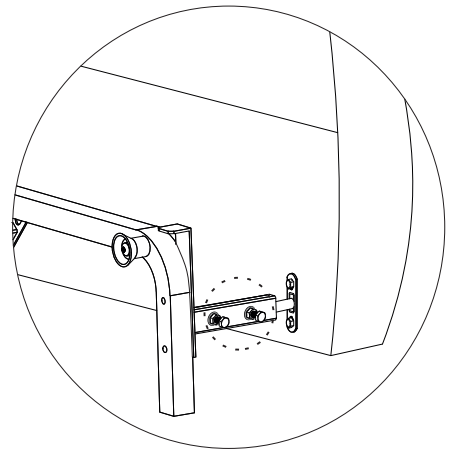
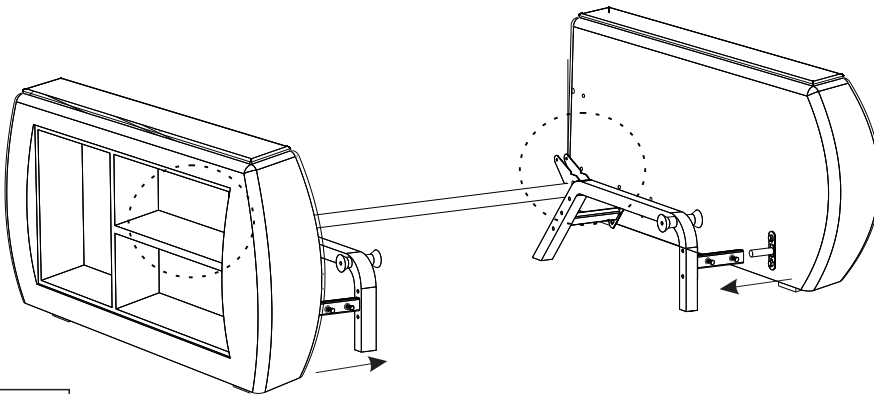

Vissez les supports d'arrière. Ne serrez pas les boulons des supports de devant.

8)

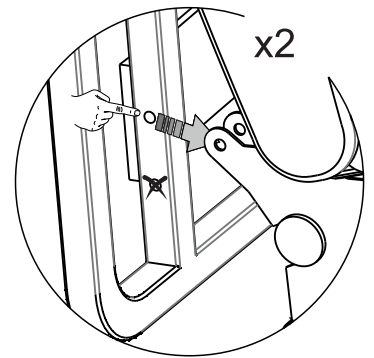
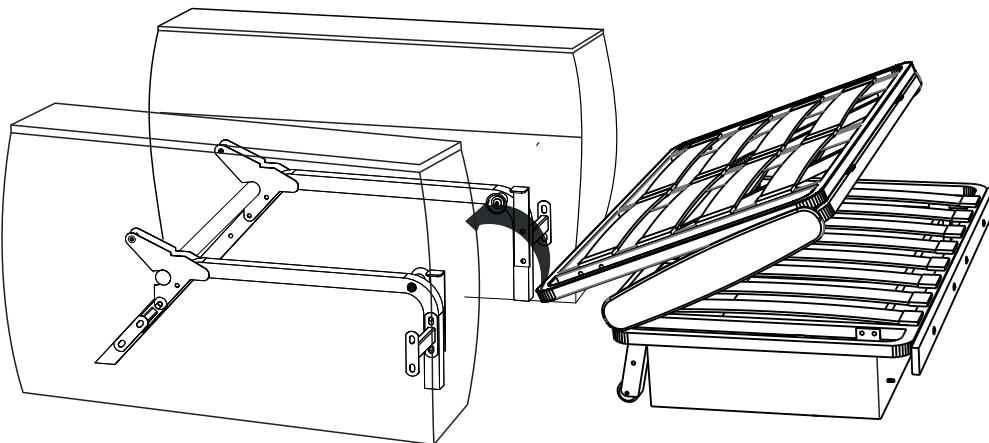

9)

Ne serrez pas trop.

x2

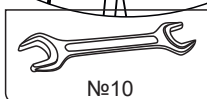
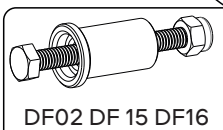
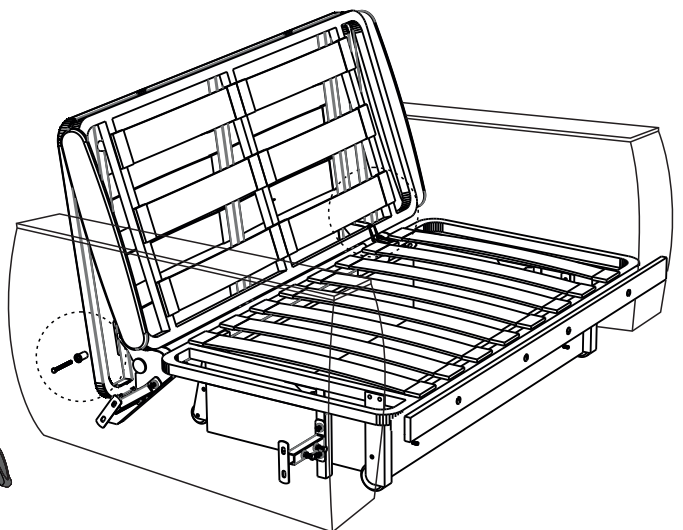
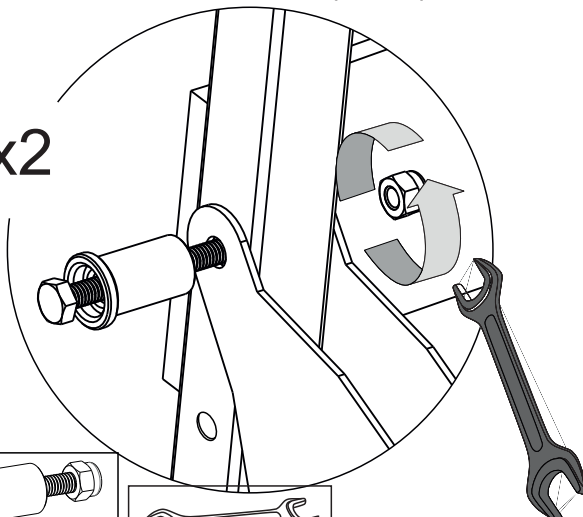



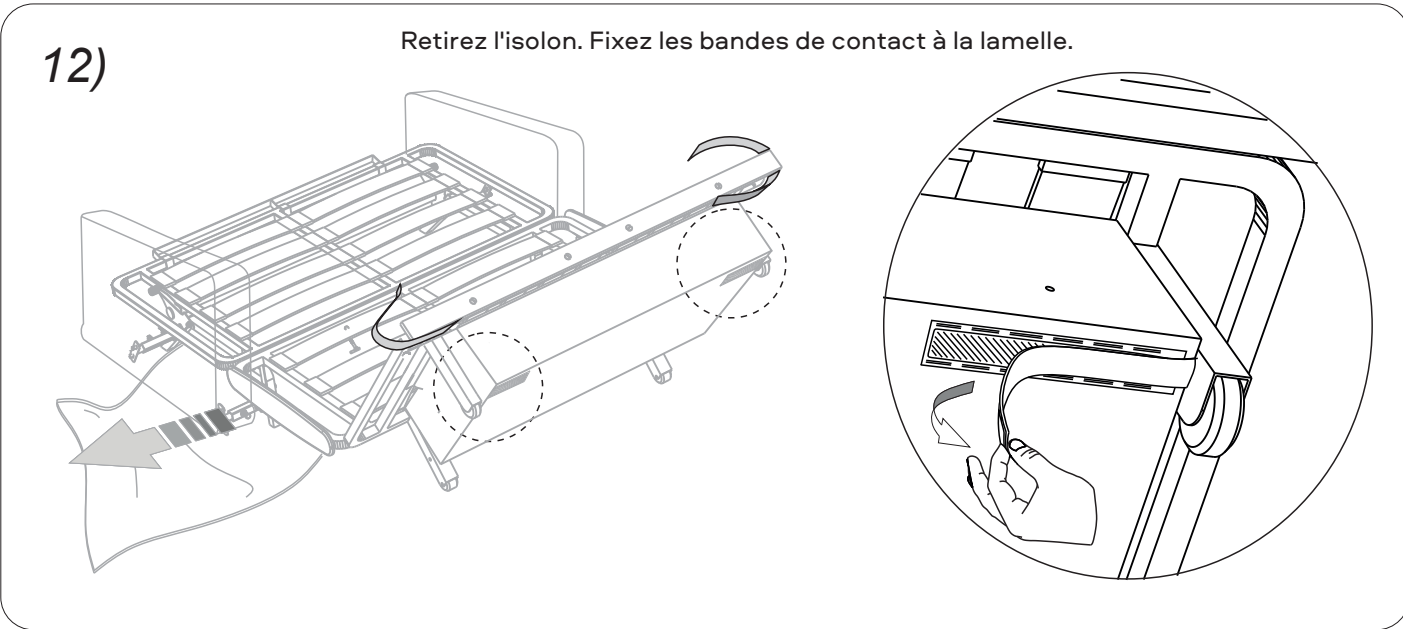
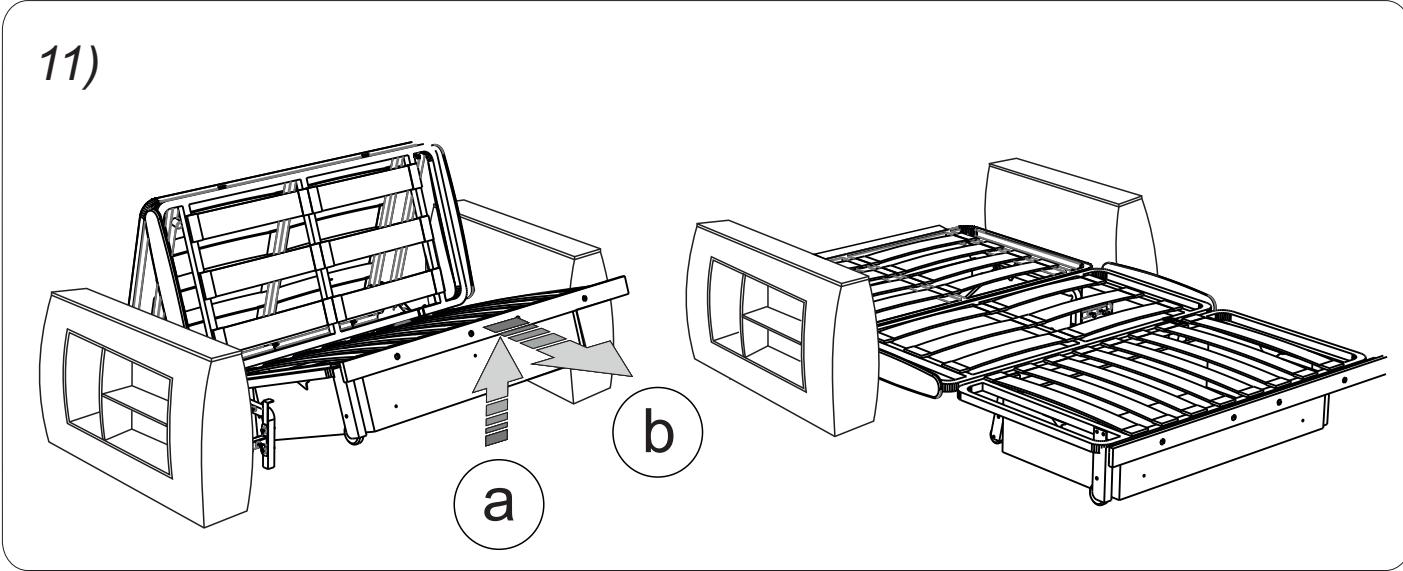
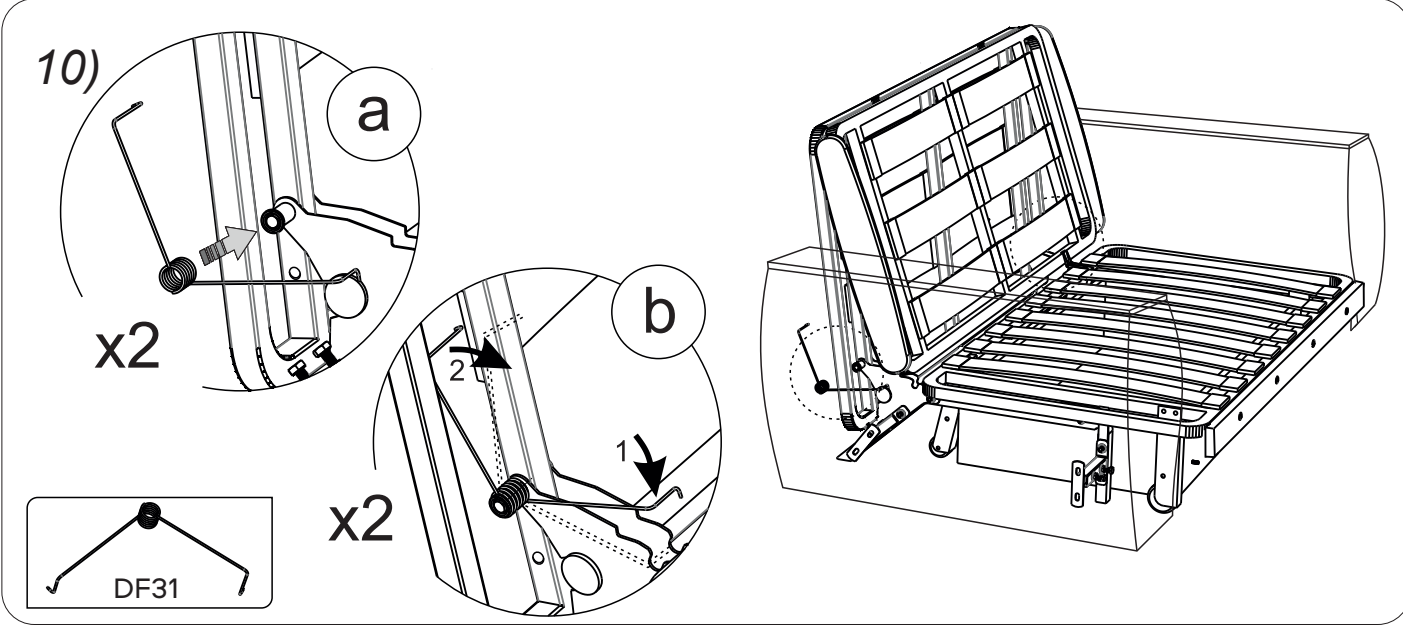

13)

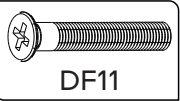
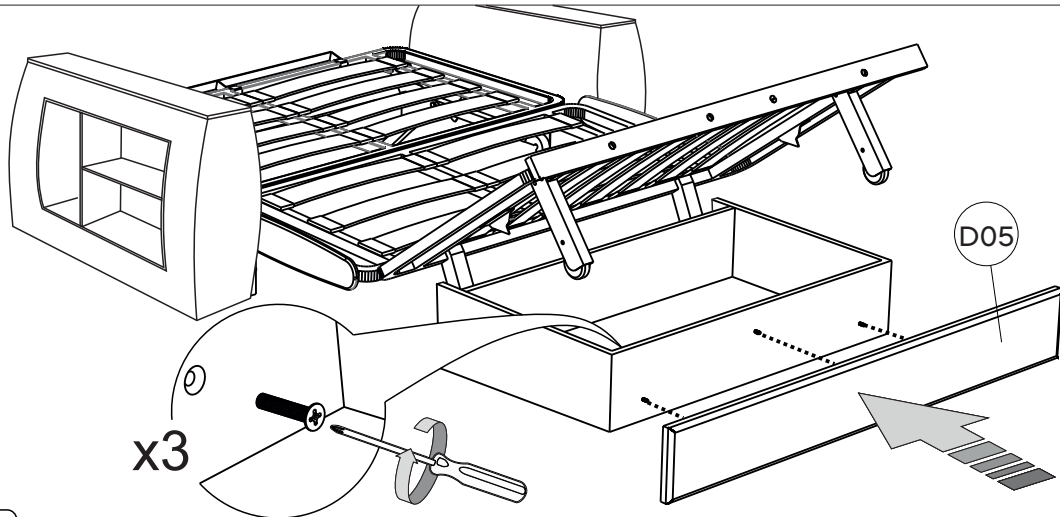

Le bas du cadre est déterminé par la présence d'une bande de bride.

14)

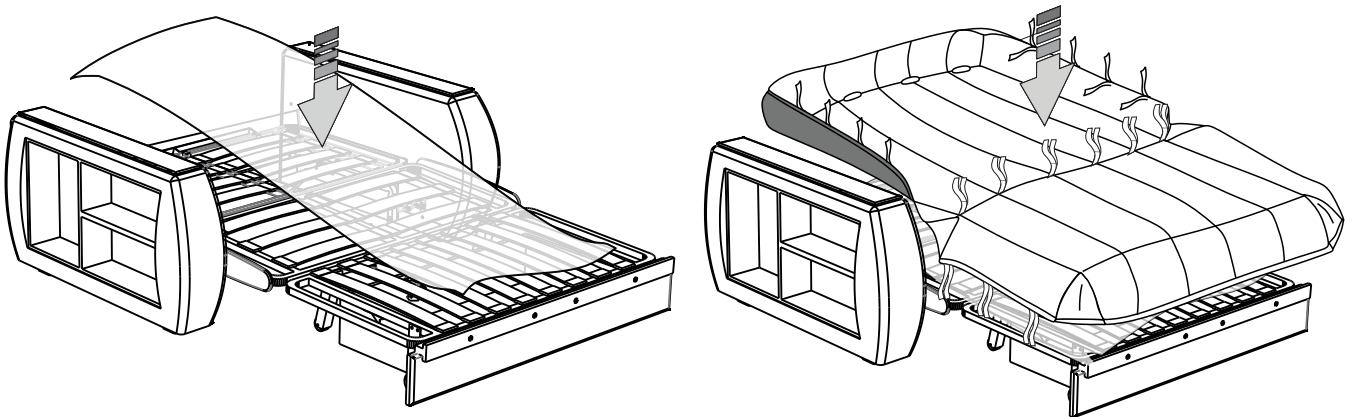

Couvrez le mécanisme de pellicule rigide pour protéger la housse contre la graisse.

15)

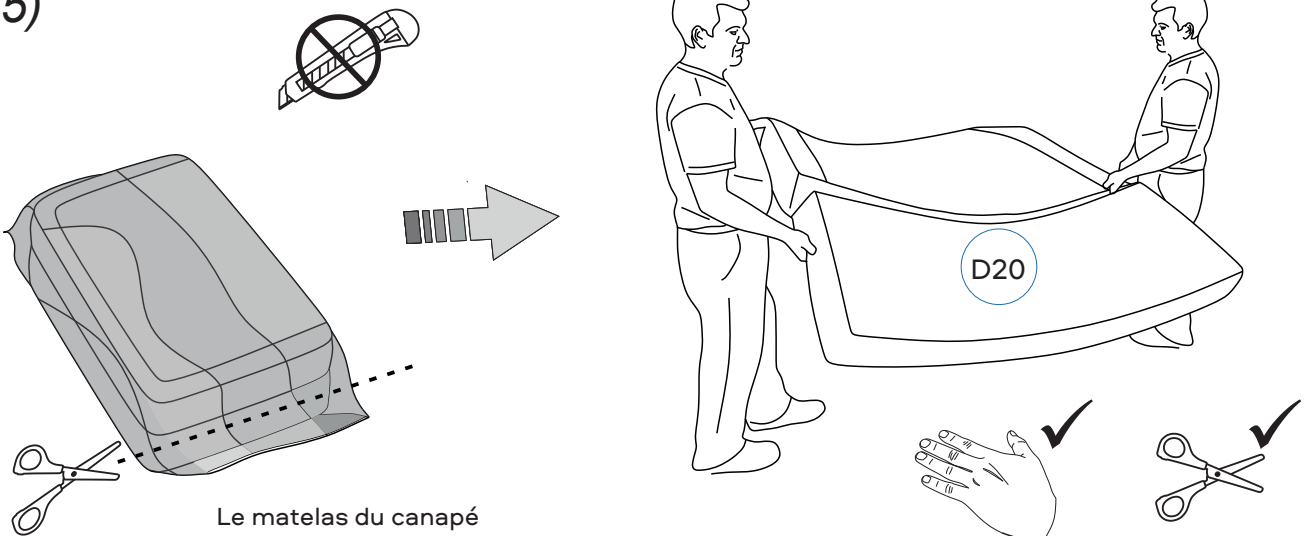

Le matelas du canapé

16)

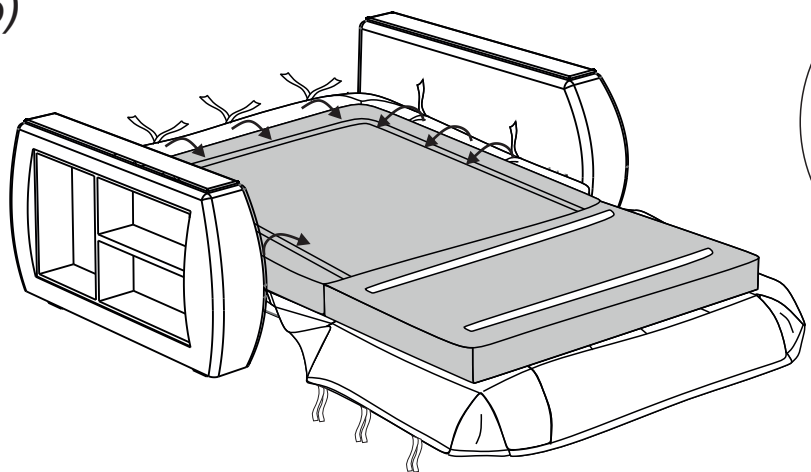

Alignez les coutures et les coins du matelas et de la housse. Au niveau de la tête de lit, enfitez les bandes de contact dans les trous de la housse.

17)

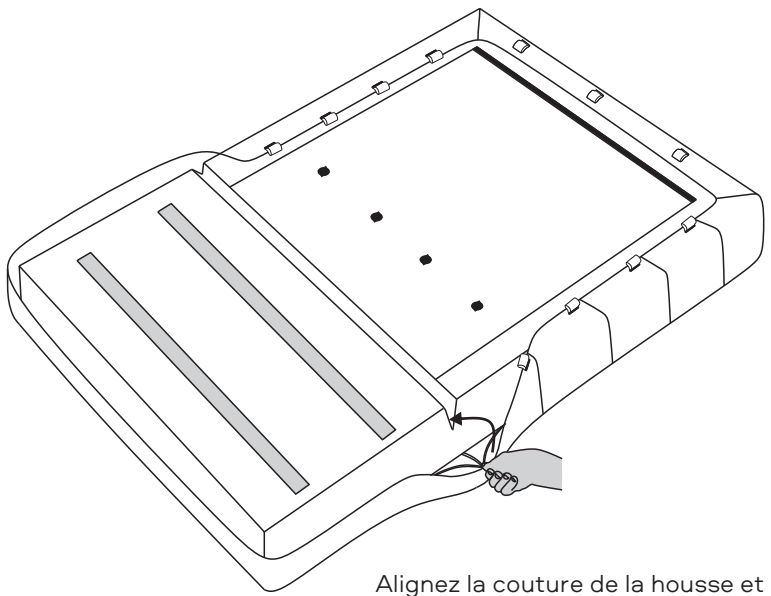

Alignez la couture de la housse et du matelas.

18)

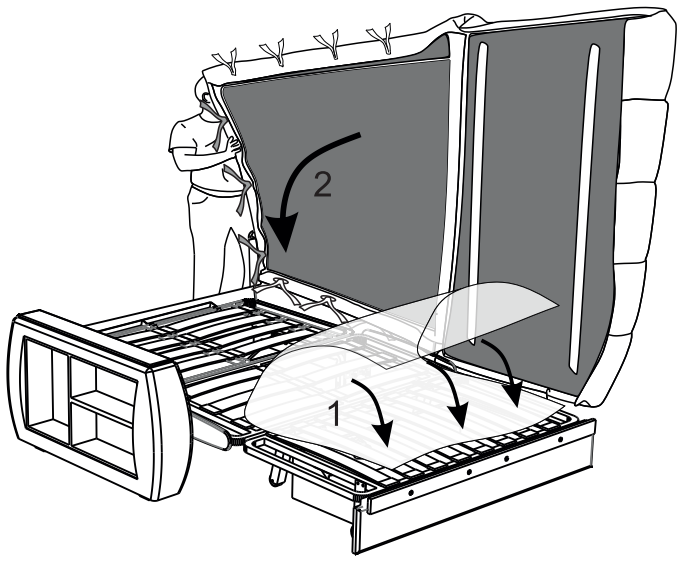

19)

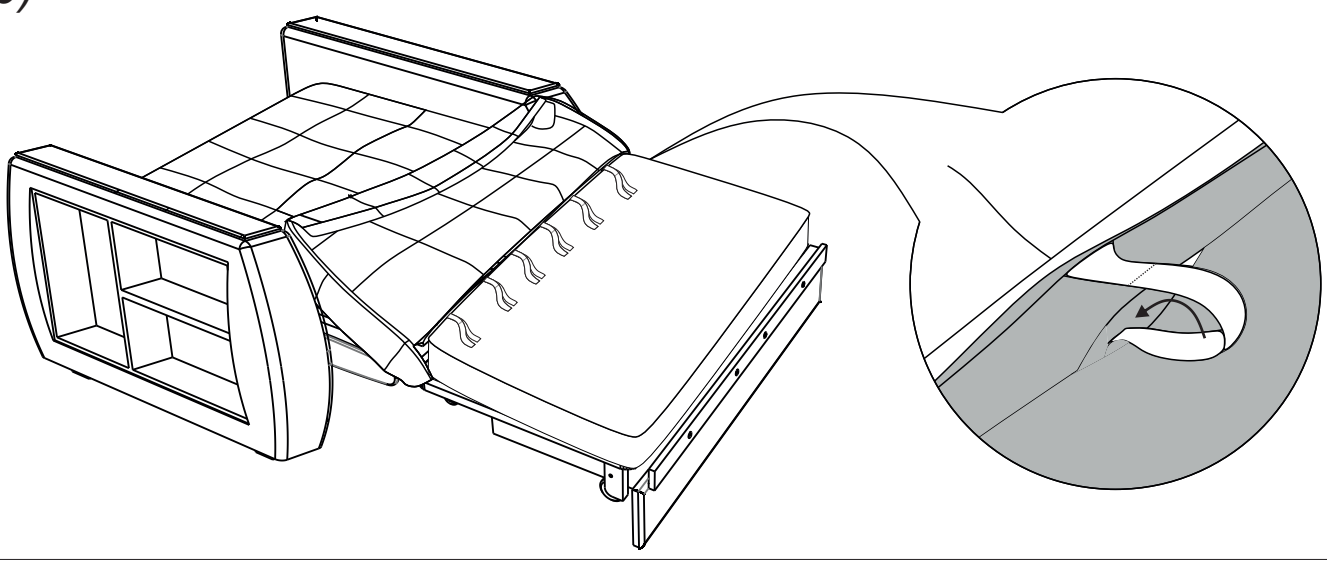

20)

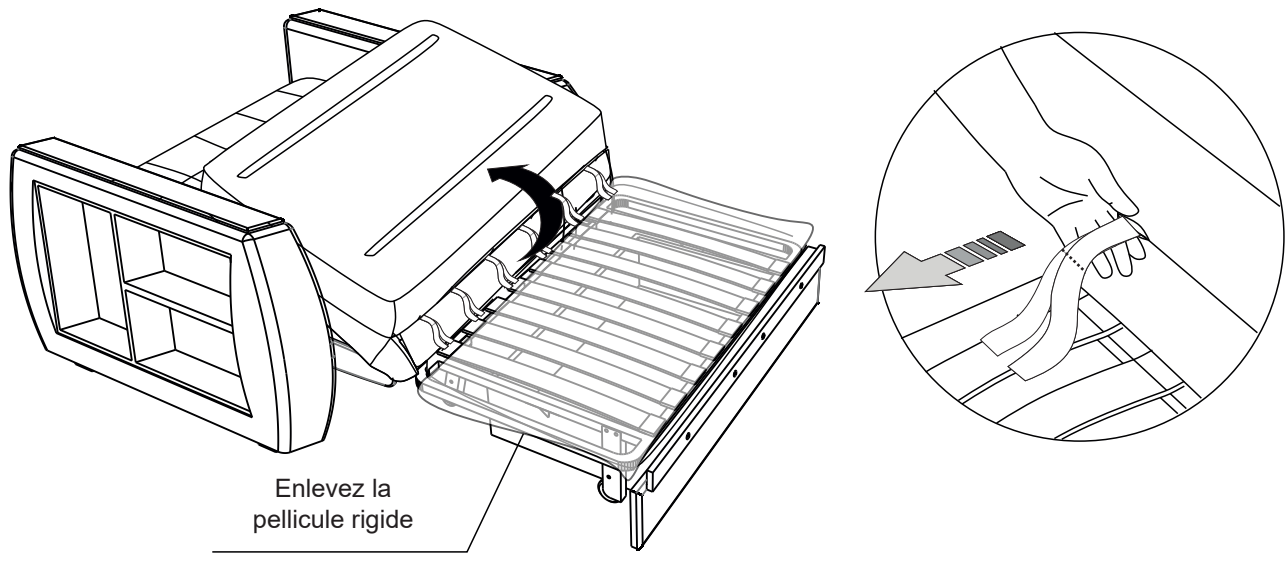

21)

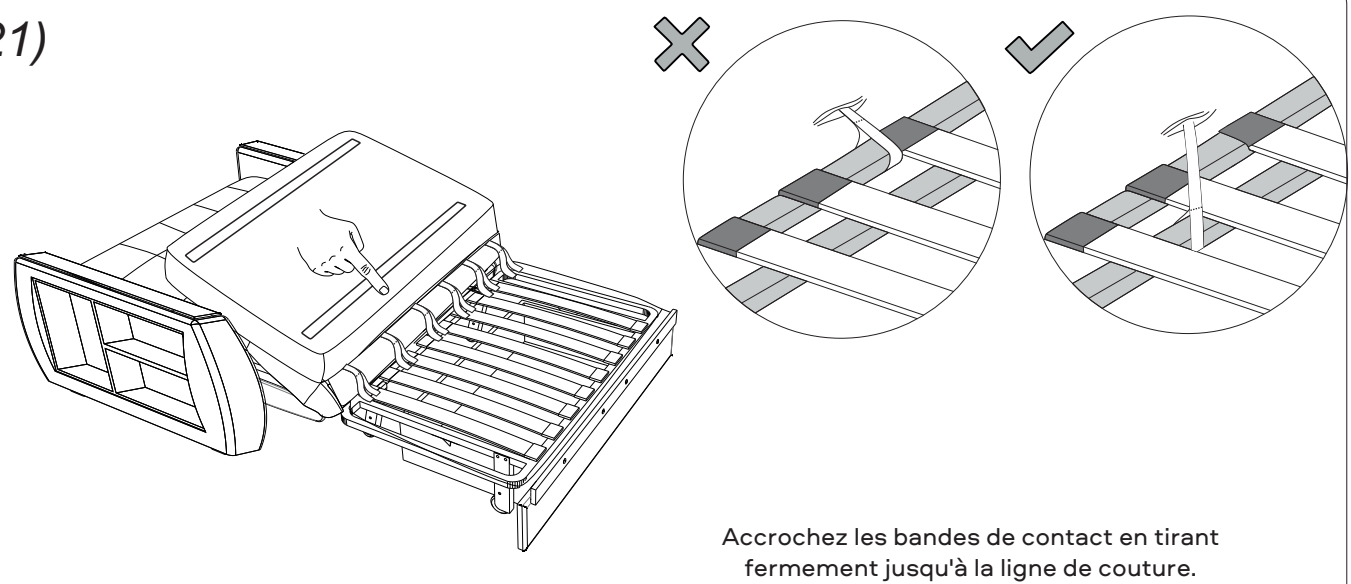

22)

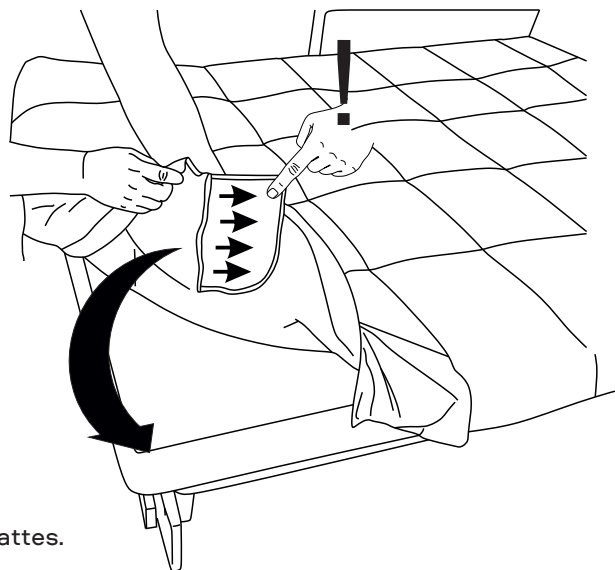
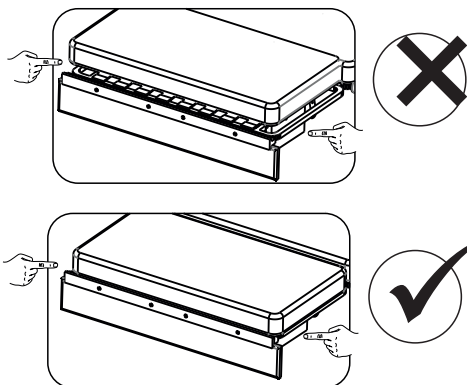

Le matelas ne doit pas dépasser de plus de 1 cm du bord des lattes.

23)

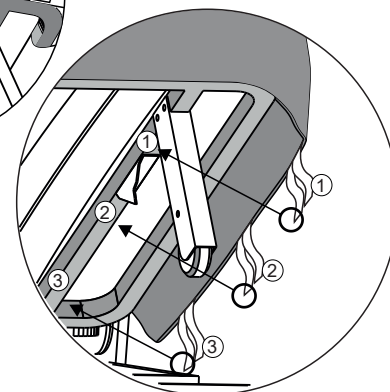
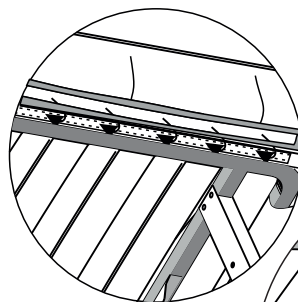
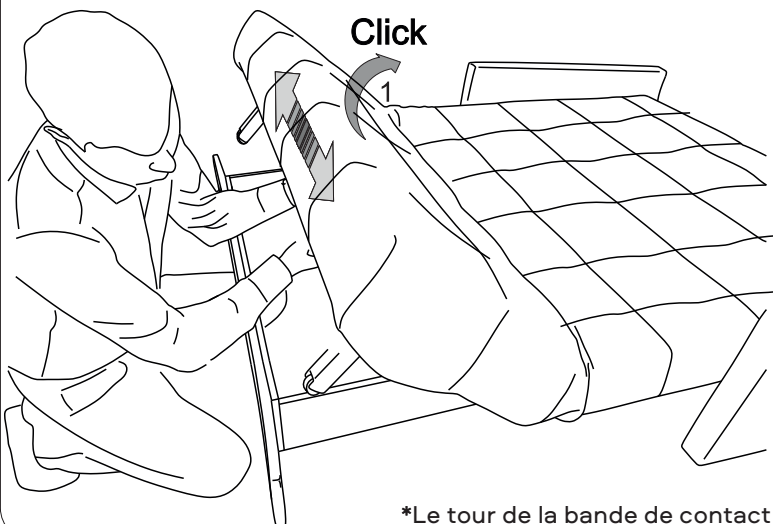

\*Le tour de la bande de contact est un anneau complet

24)

Pour rendre la transformation plus facile, réunissez l'excédent de la housse à l'endroit de pliage du matelas.

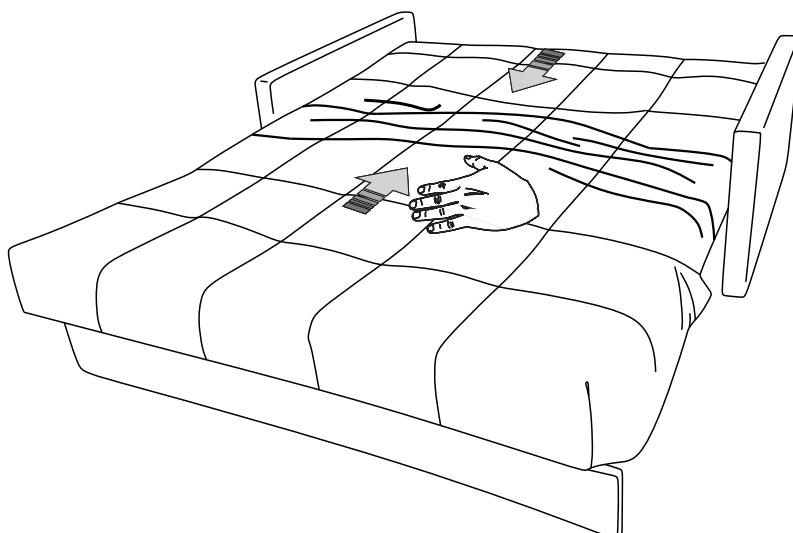

25)

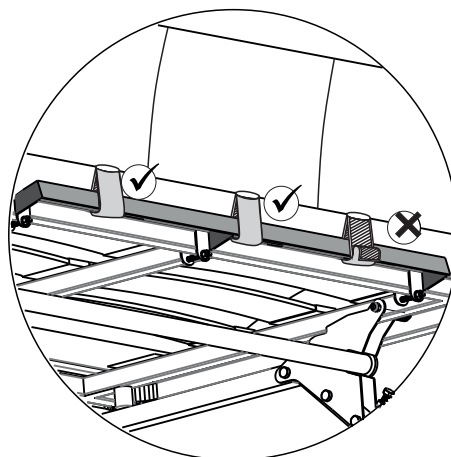
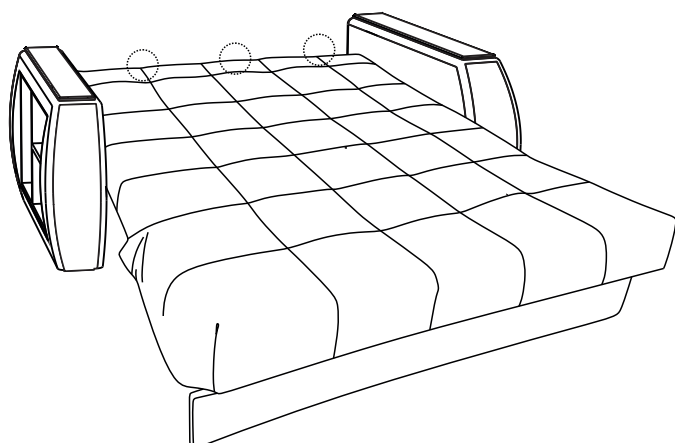

26)

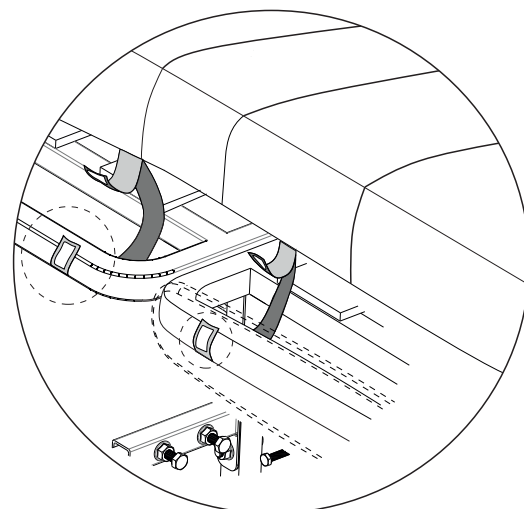
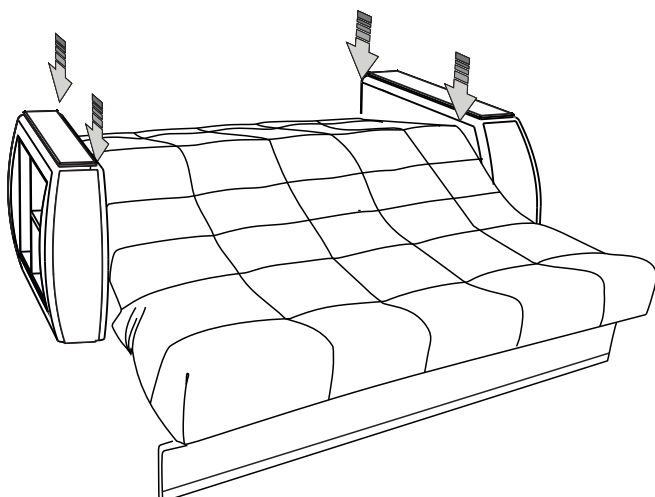

Lors de la fixation, le canapé doit être demi-déplié et les bandes de contact doivent être serrées au maximum.

27)

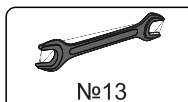
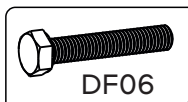
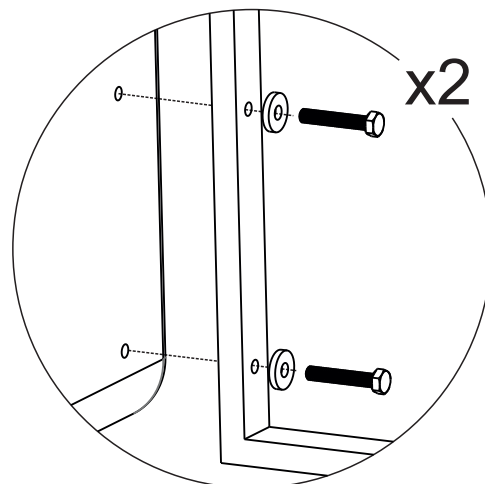
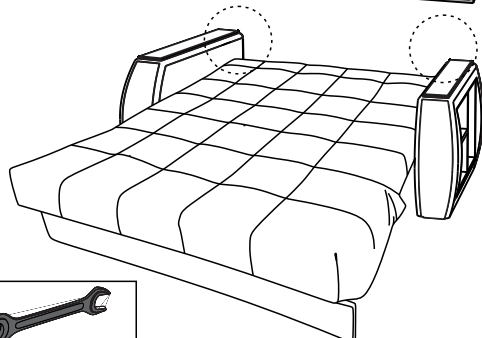
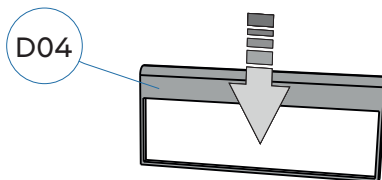



Taille jetez le canapé, procédez à l'assemblage du canapé d'angle

28)

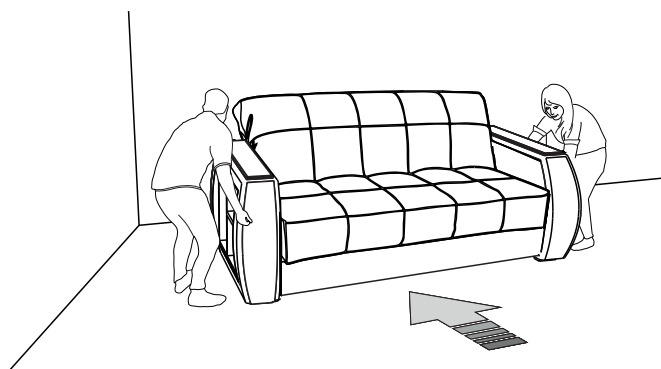

$A \approx B$  OK

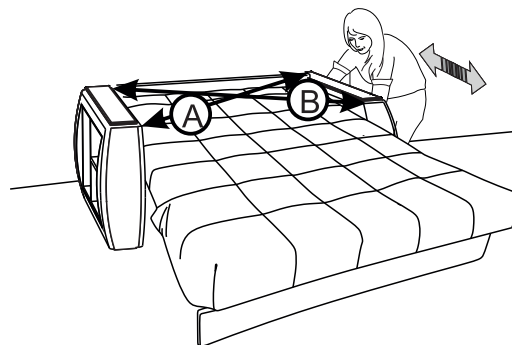

Installez le canapé dans un endroit de son exploitation permanente.

29)

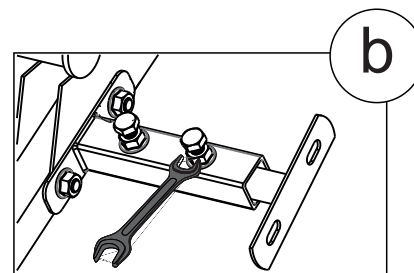
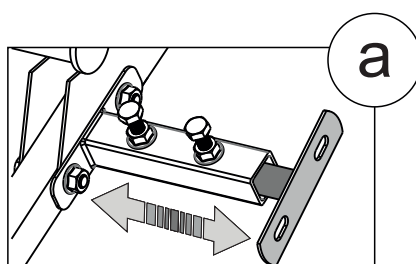
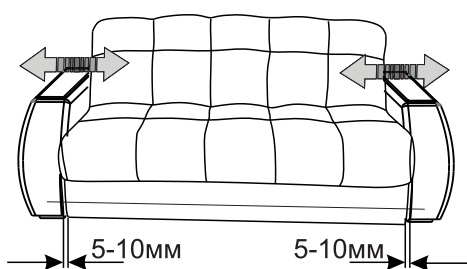

Serrez !

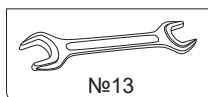

N°13

30)

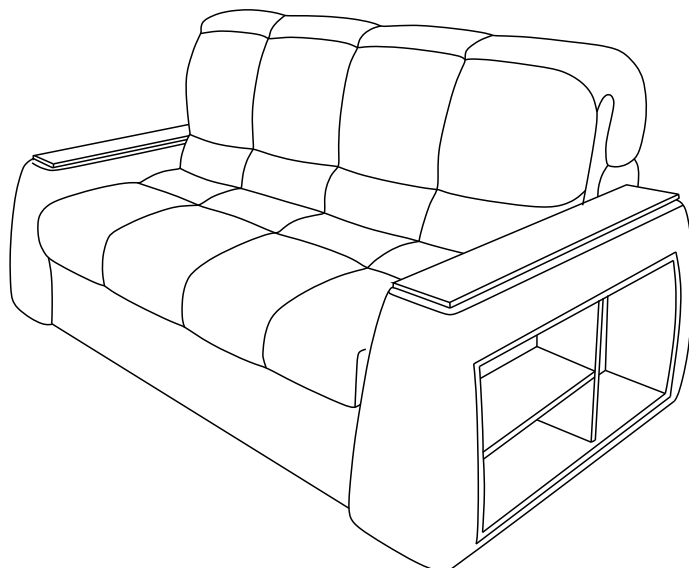



## Assemblage du canapé d'angle

31)

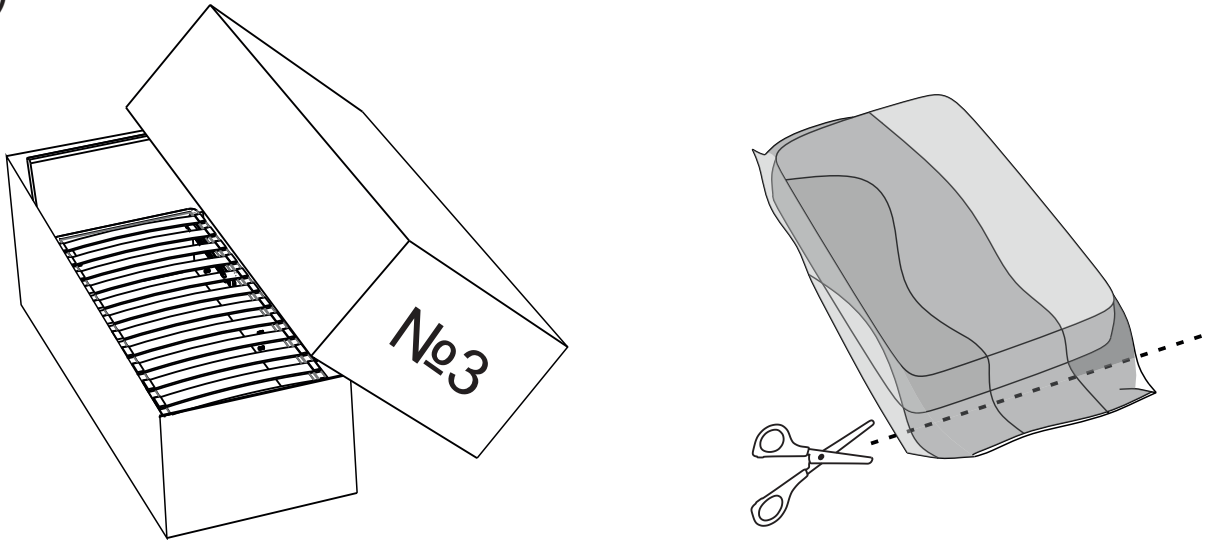

32

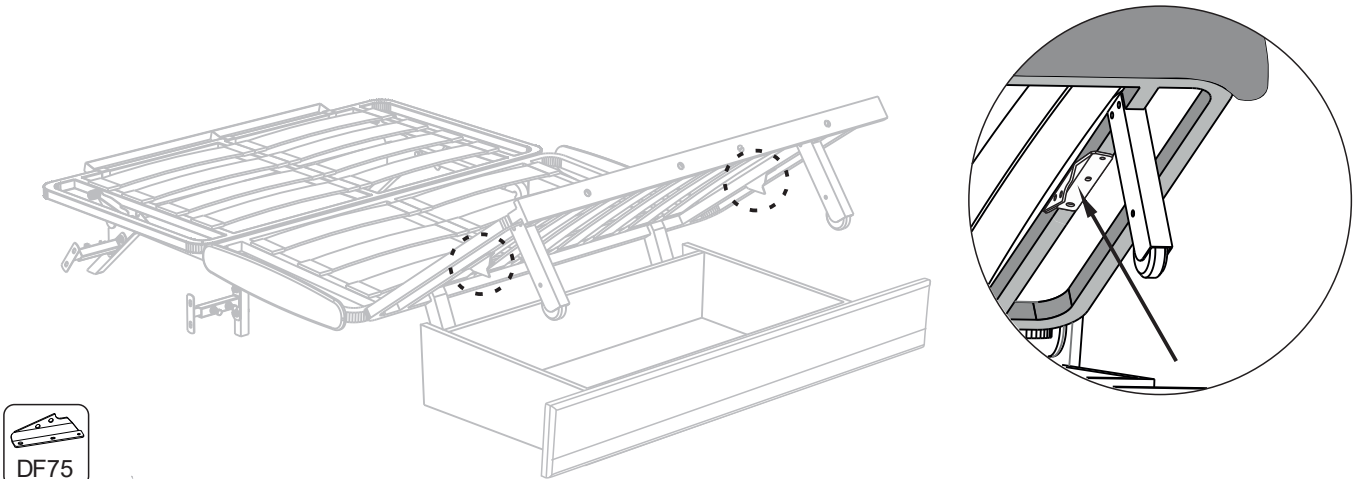

33)

Les ressorts sont installés uniquement sur un petit canapé

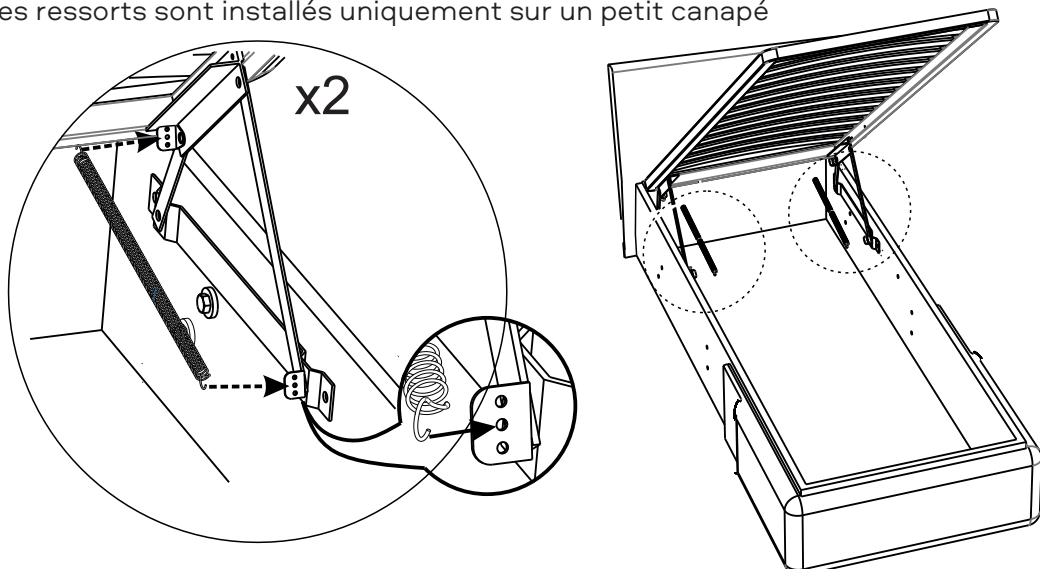

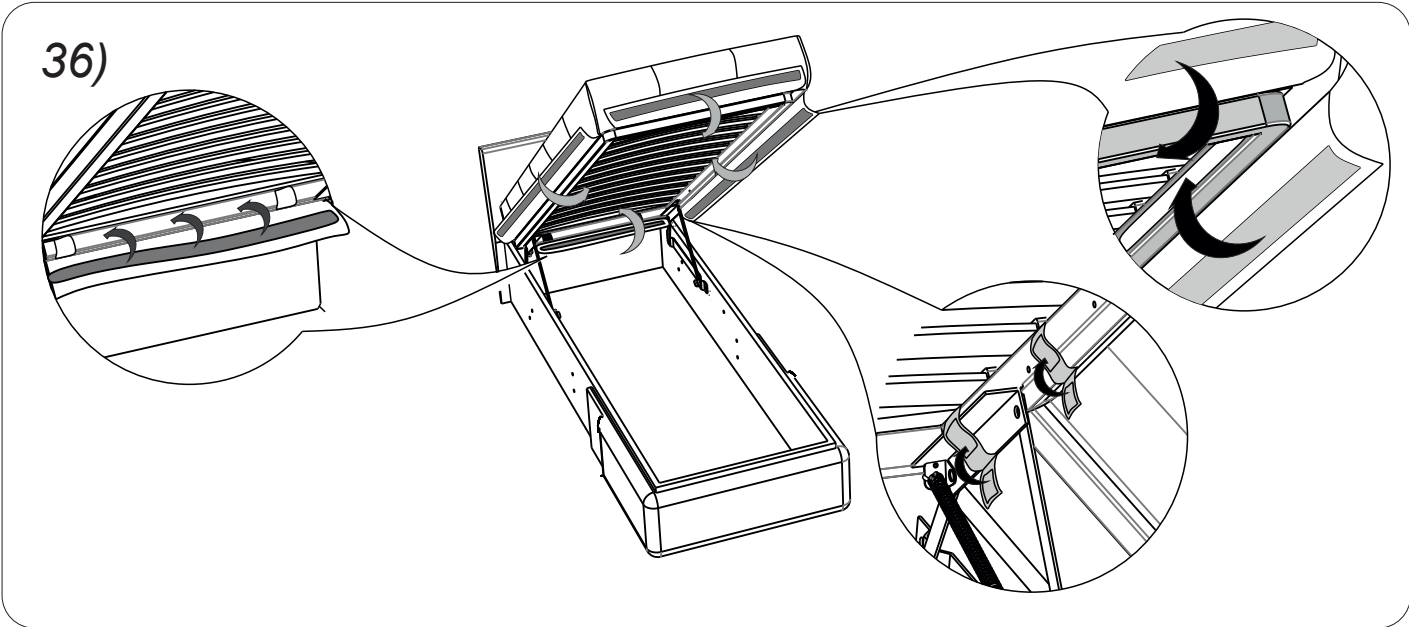
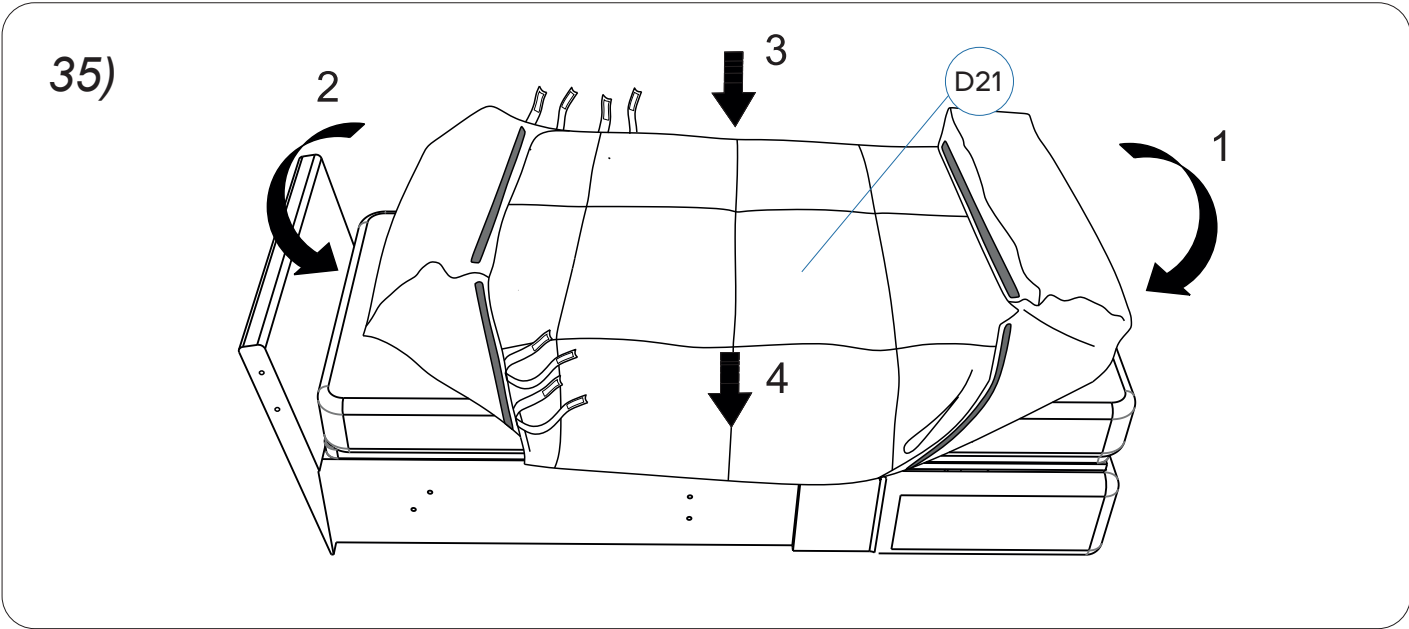
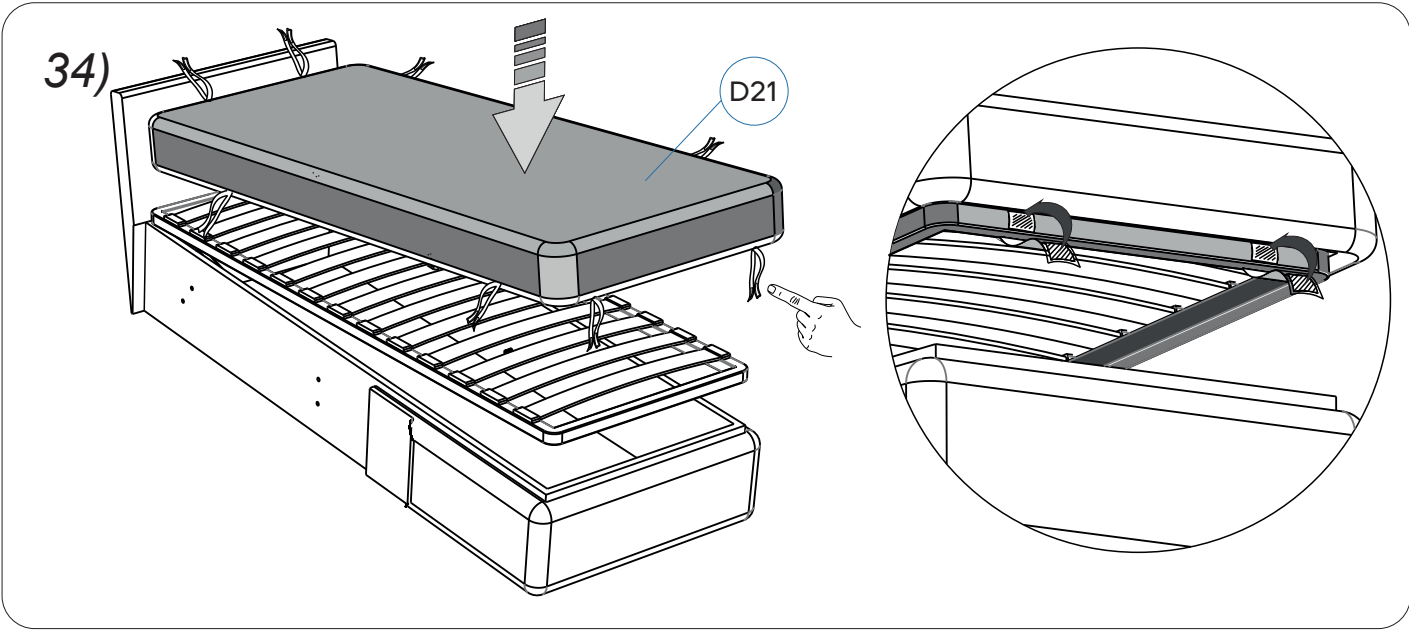

37)

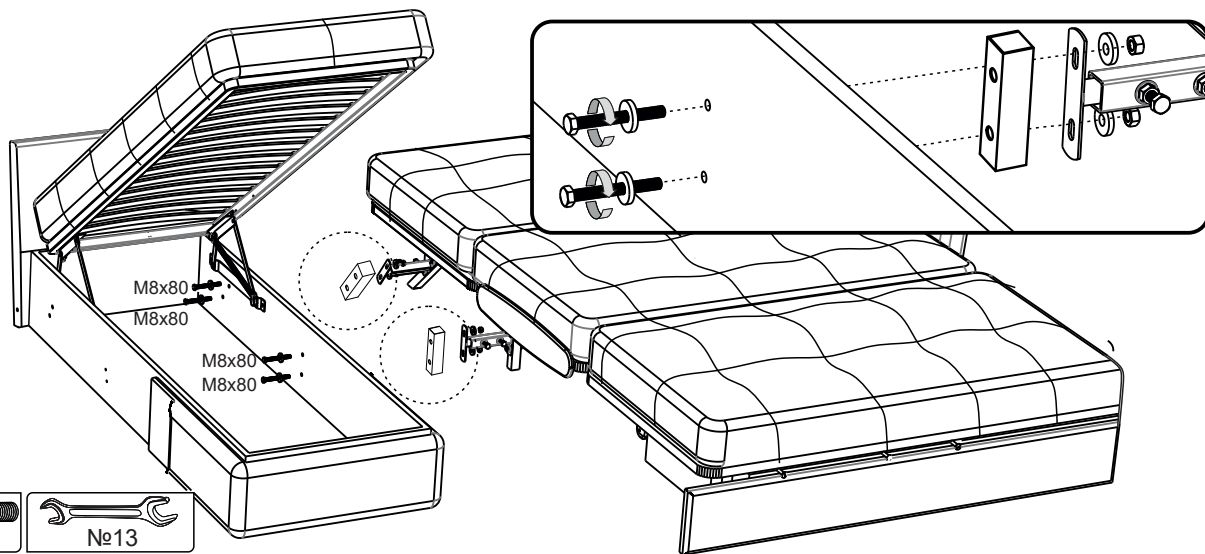

38)

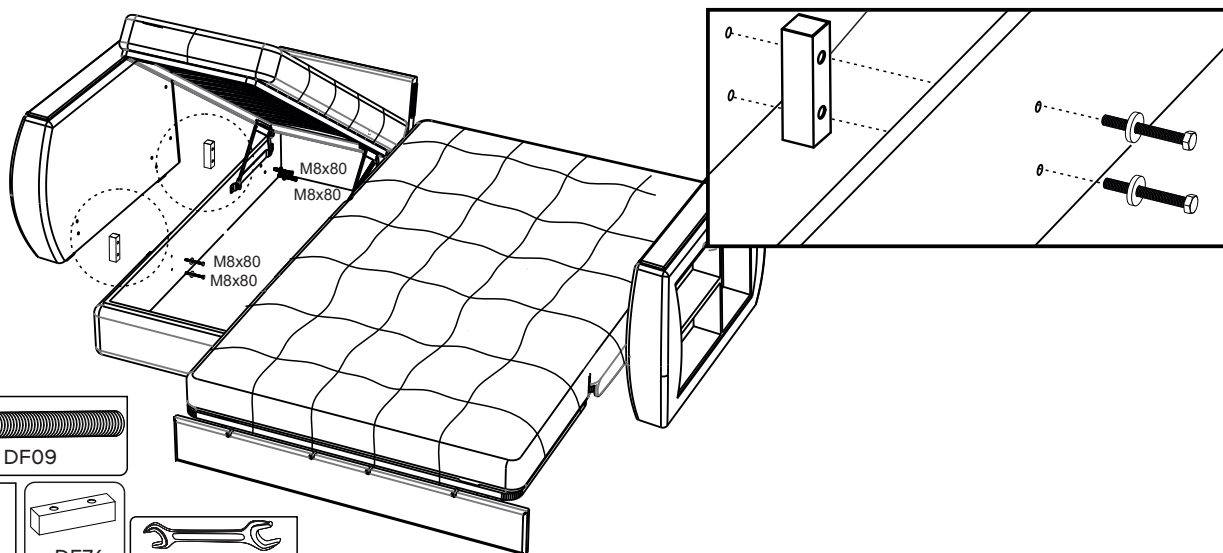

39)

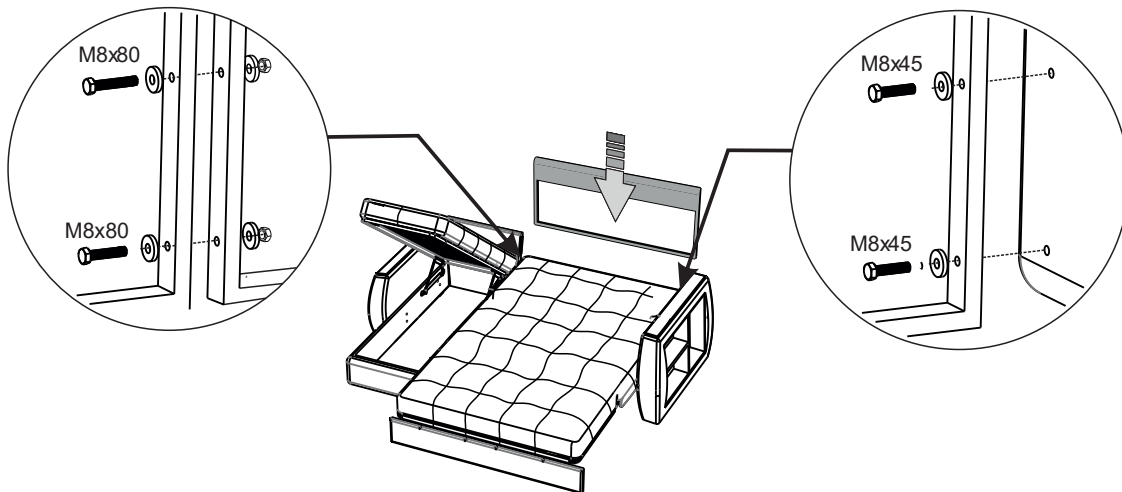

40)

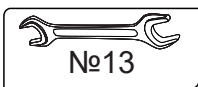
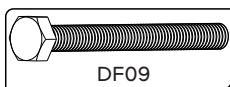
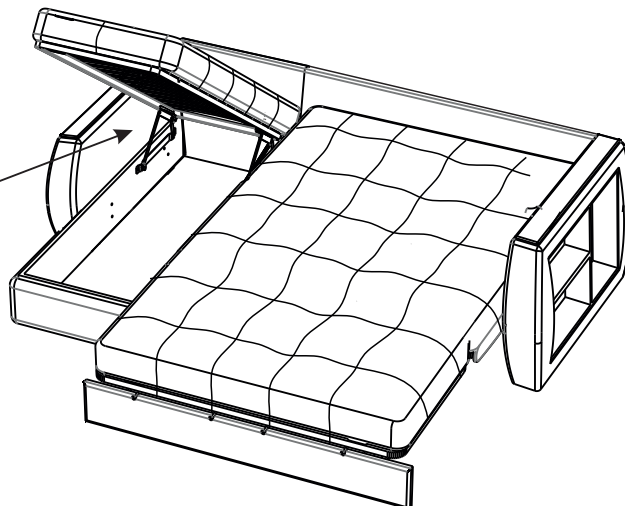
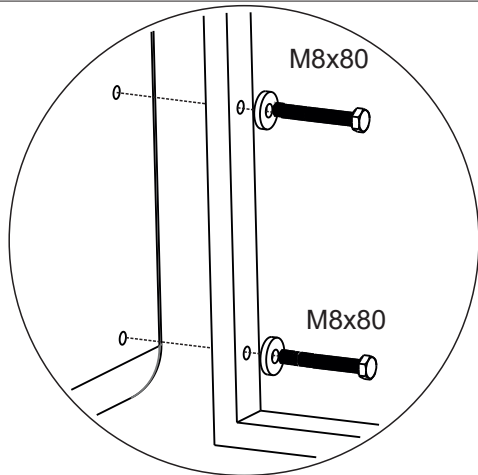

41)

1

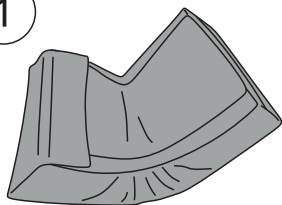

2

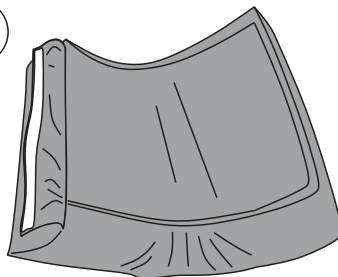

3

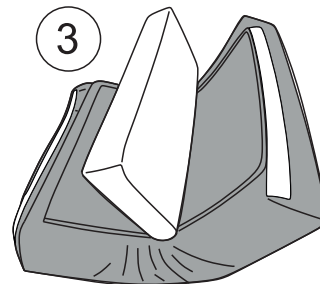

4

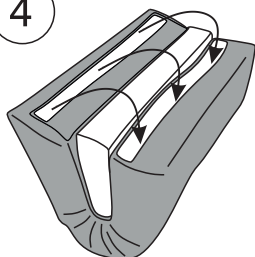

5

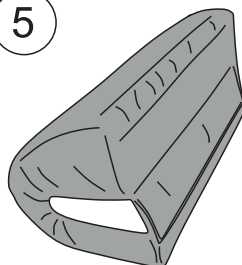

6

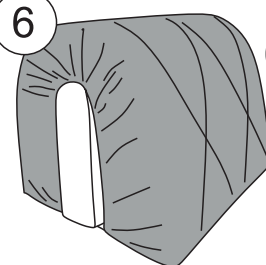

42)

b

a

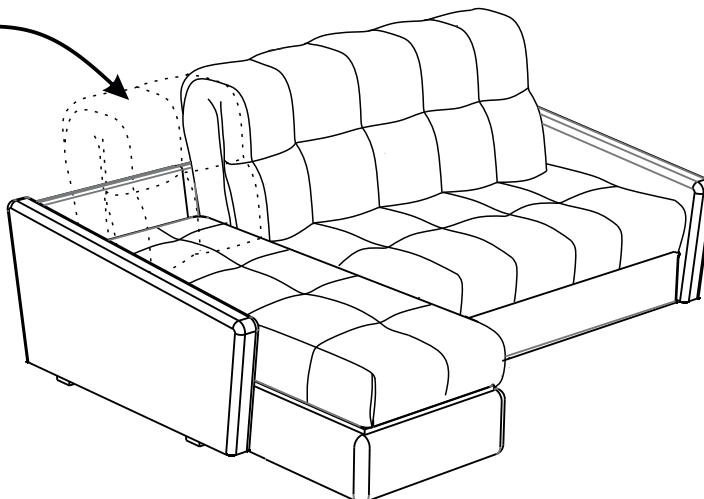
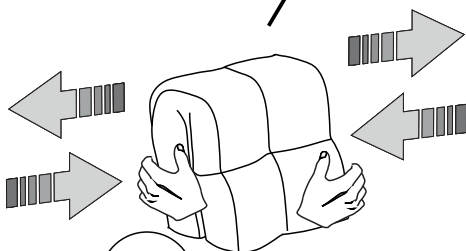

43)

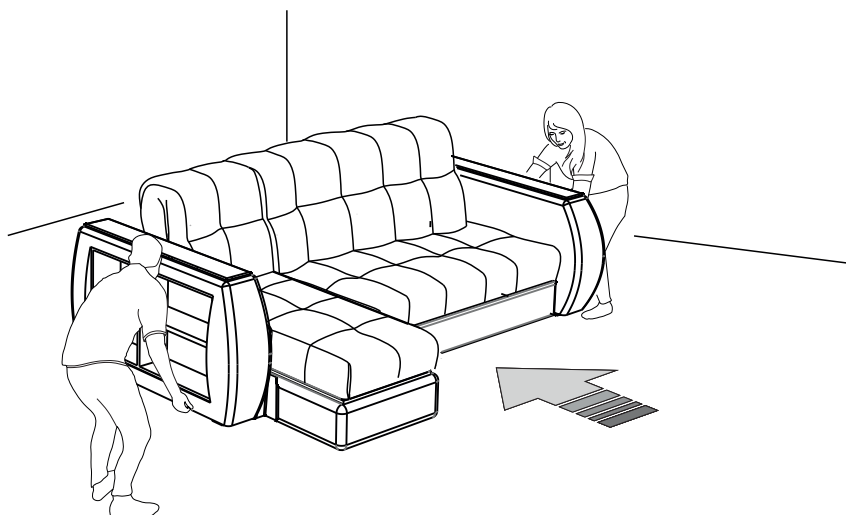

Installez le canapé dans un endroit de son exploitation permanente.

44)

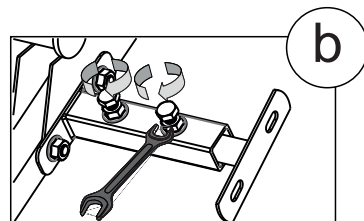
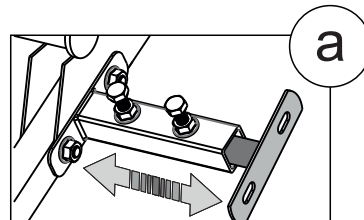
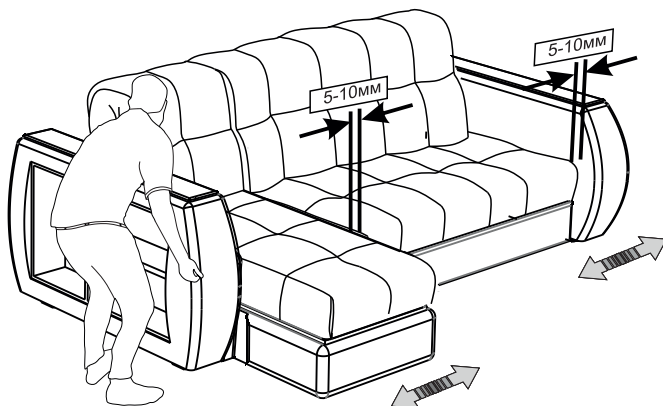

Serrez !



45)

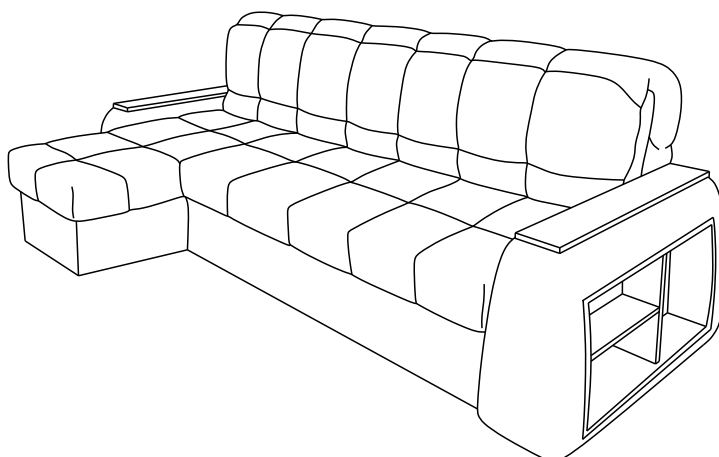

## Ordre de transformation du canapé

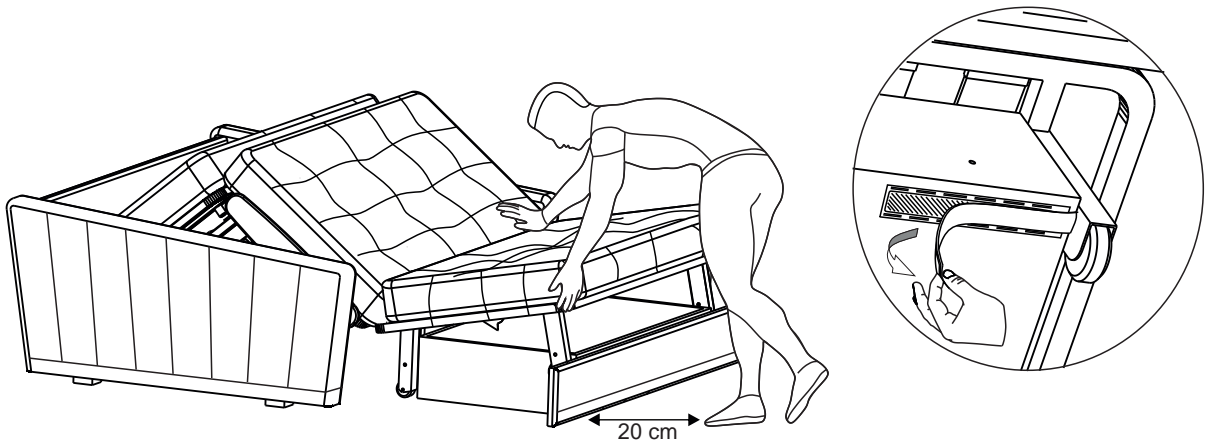
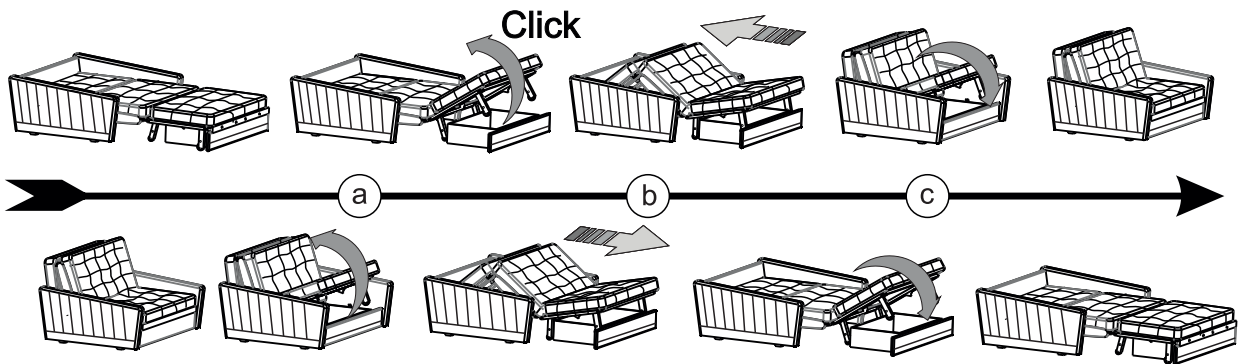

Si le siège du canapé ne se lève pas, détachez le Velcro d'expédition.

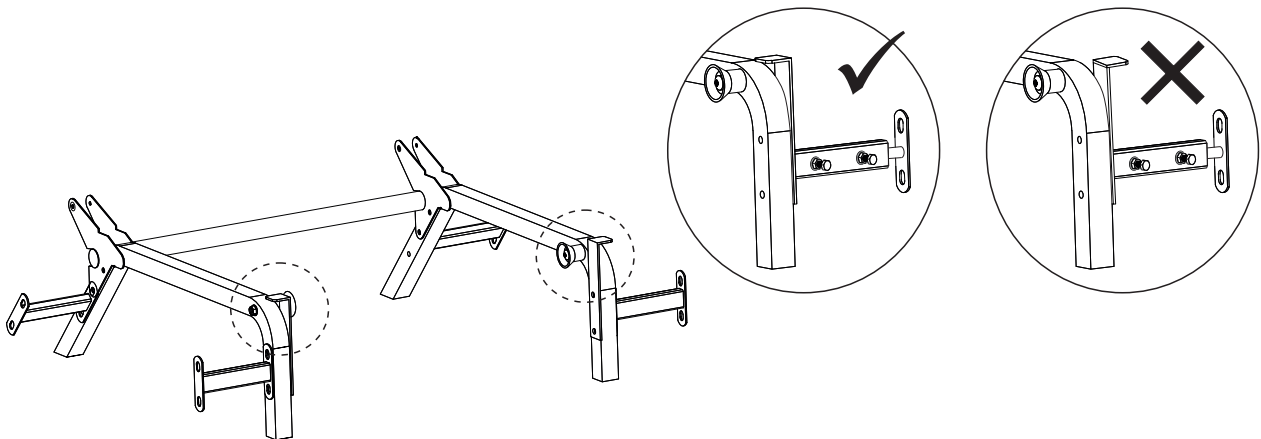

Si le siège ne se plie pas, vérifiez la position des supports du mécanisme.



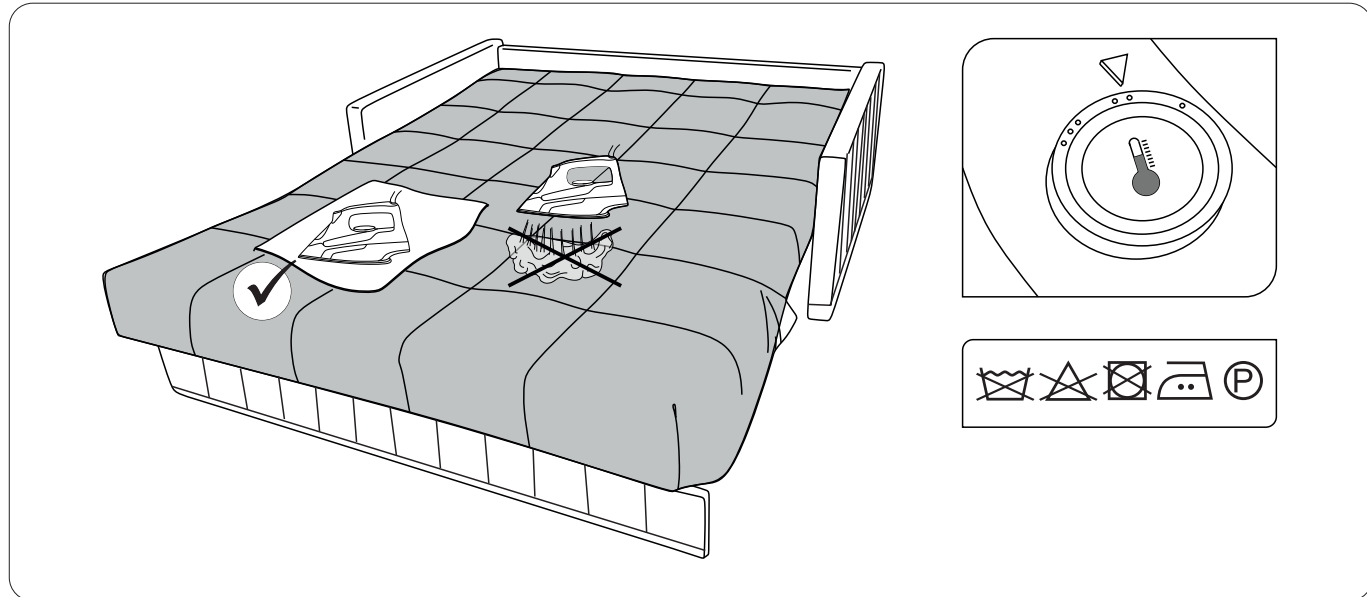
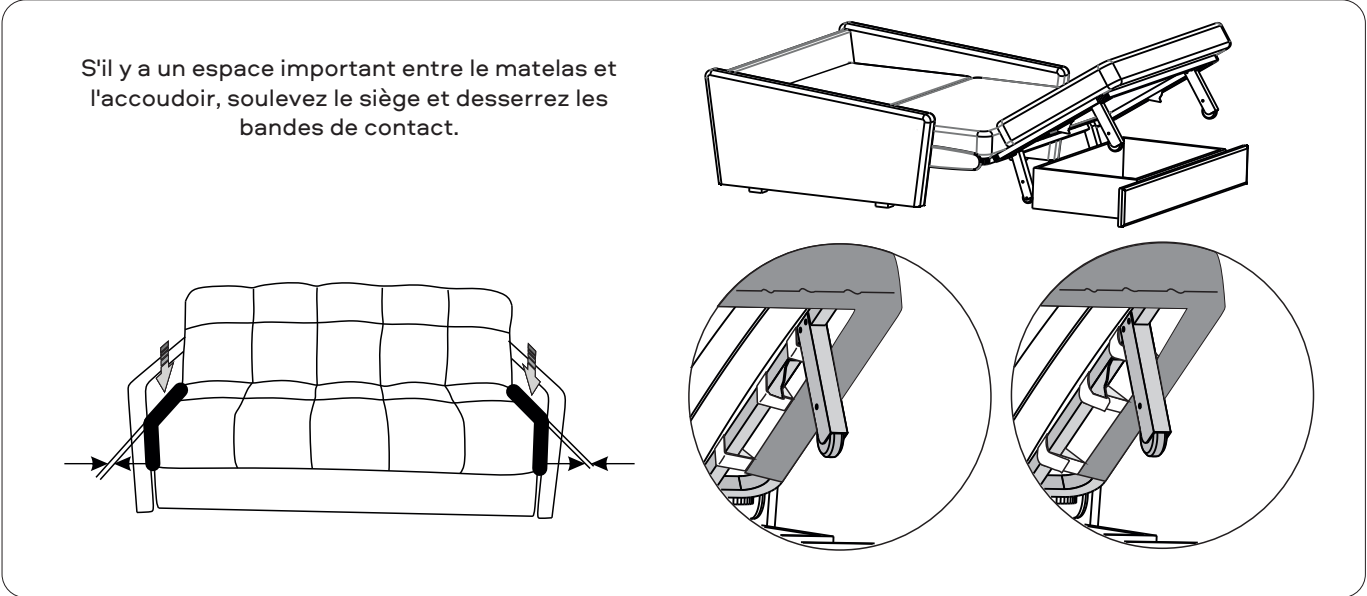
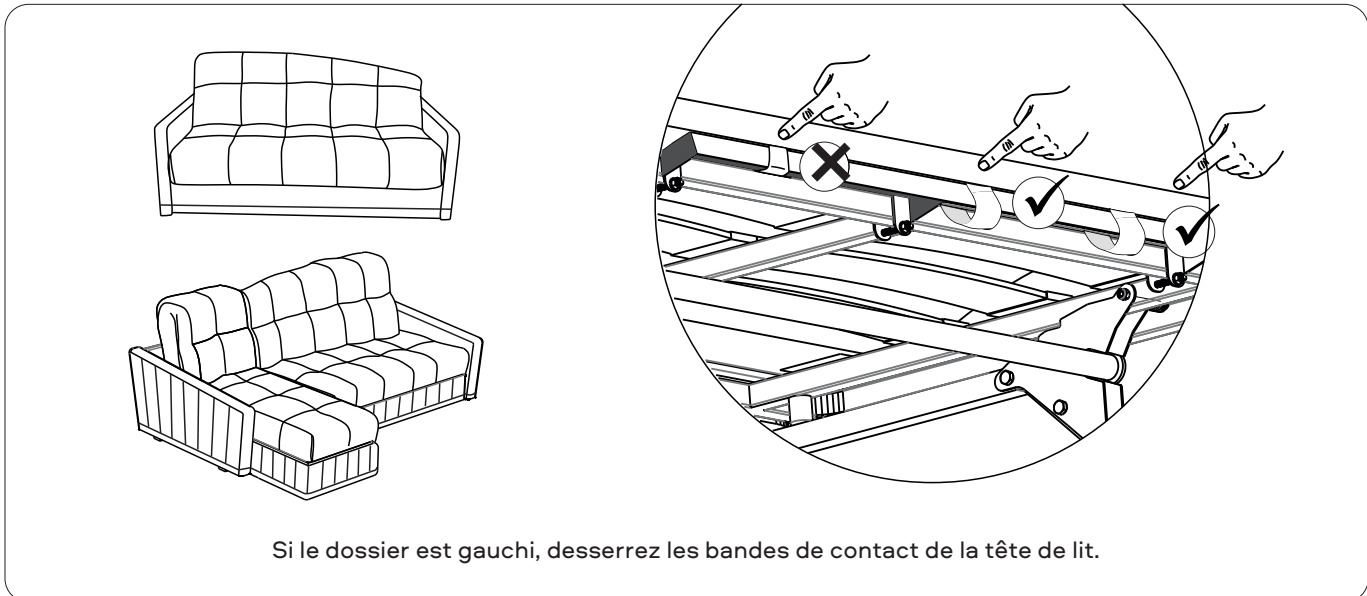



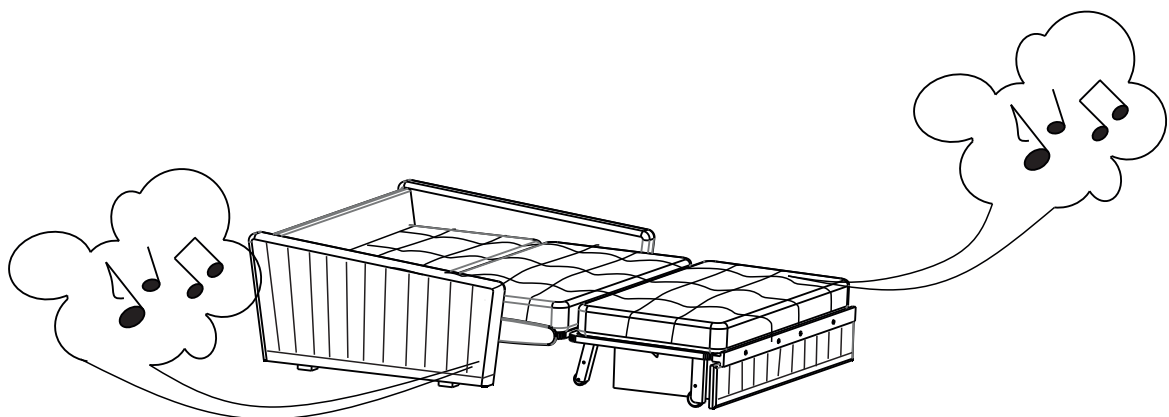

Rappelez-vous: Le craquement caractéristique des éléments métalliques du mécanisme lors de la transformation est une situation normale. Le canapé dispose d'une structure métallique fiable qui vous permet de transformer le canapé en lit tous les jours. Au cours de la transformation et du fonctionnement, le lubrifiant entre les différentes parties du mécanisme peut sécher et des frottements d'éléments métalliques les uns contre les autres apparaissent. Pour éviter ces frottements et craquements du mécanisme lors de la transformation ou de l'exploitation du canapé, il est important de respecter les recommandations suivantes:  
En cas de craquement, lubrifiez les éléments frottants du mécanisme, serrez les connexions.  
Lubrifiez au moins une fois tous les 6 mois.

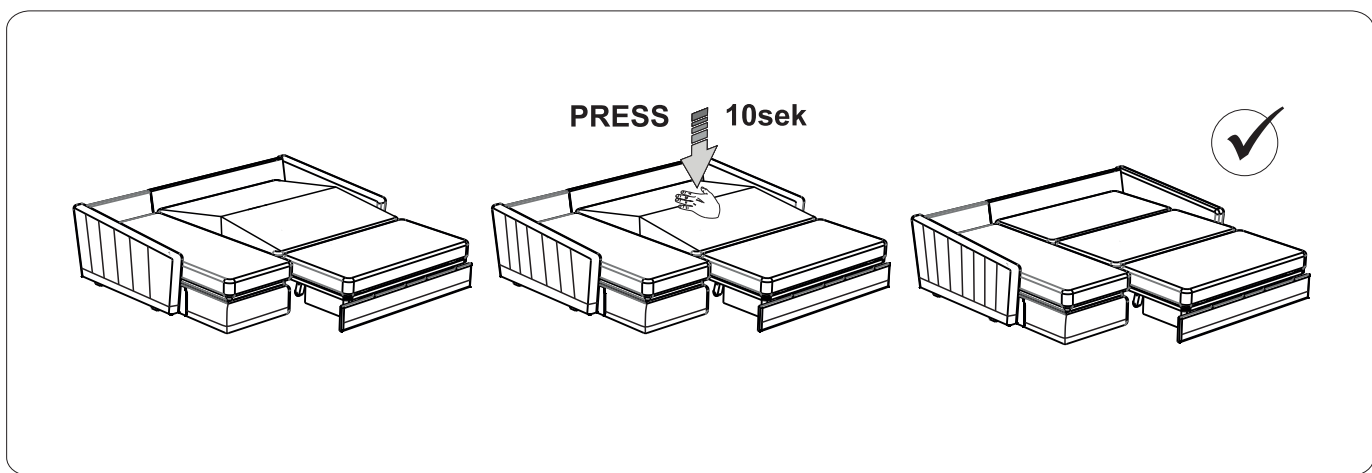
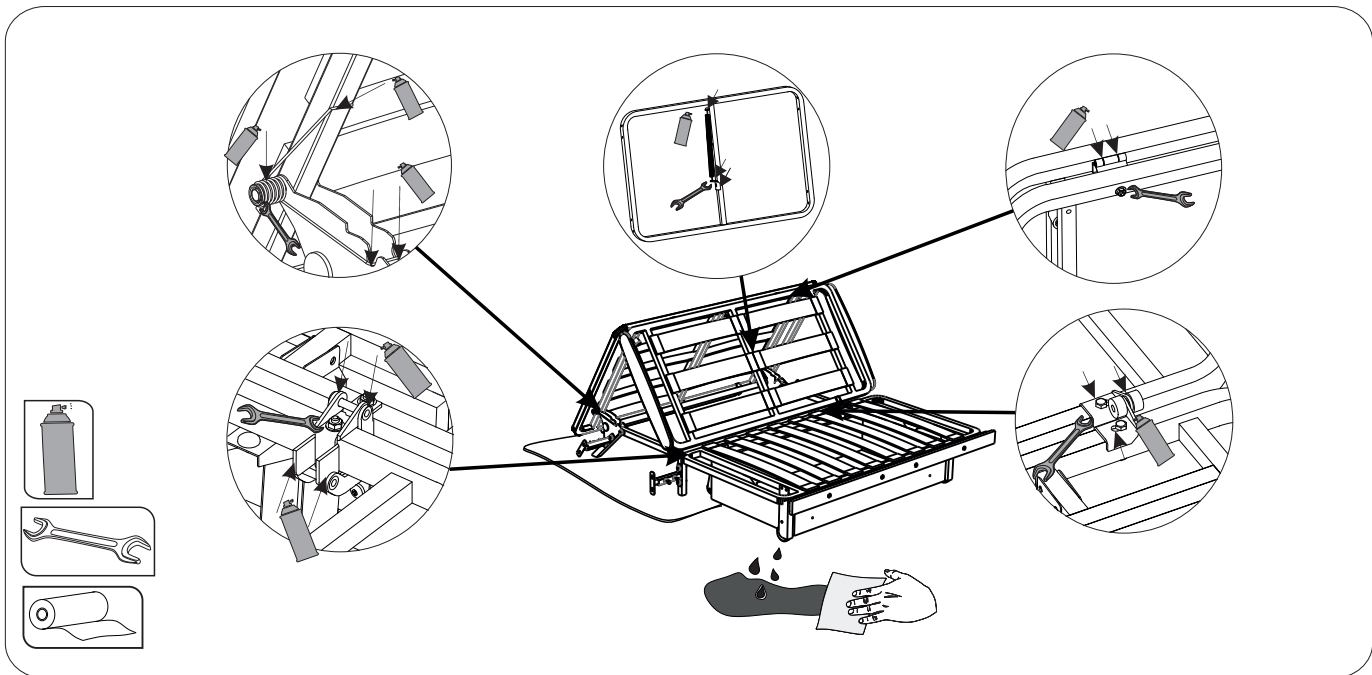

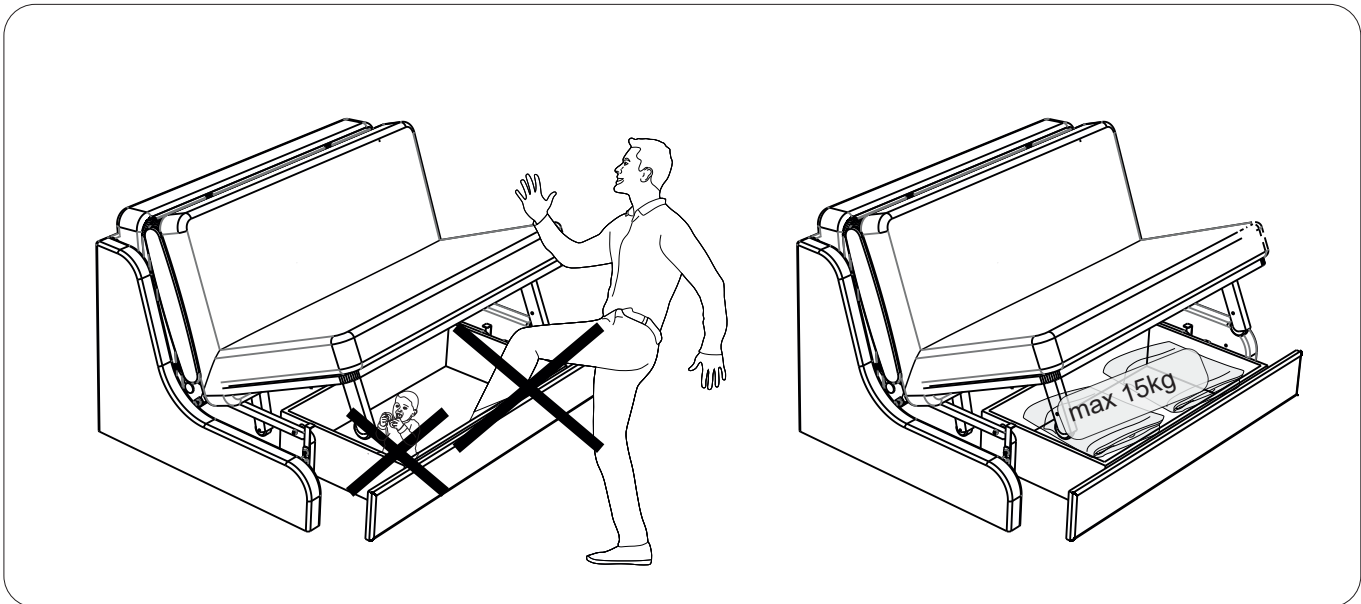
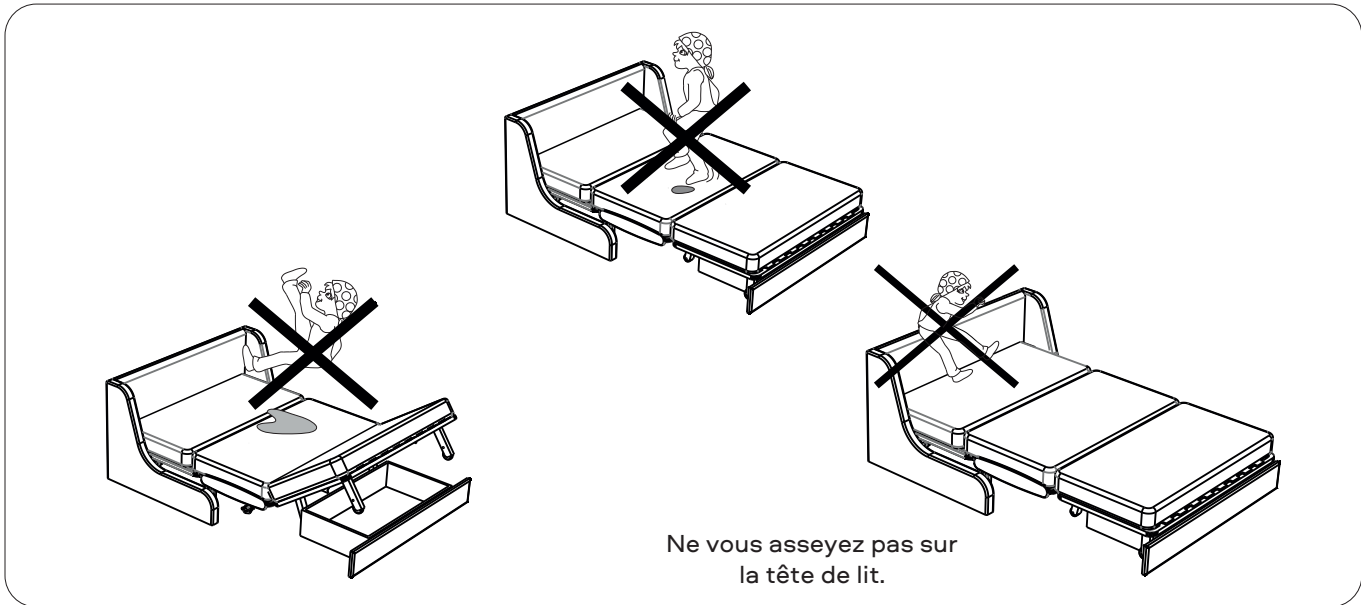
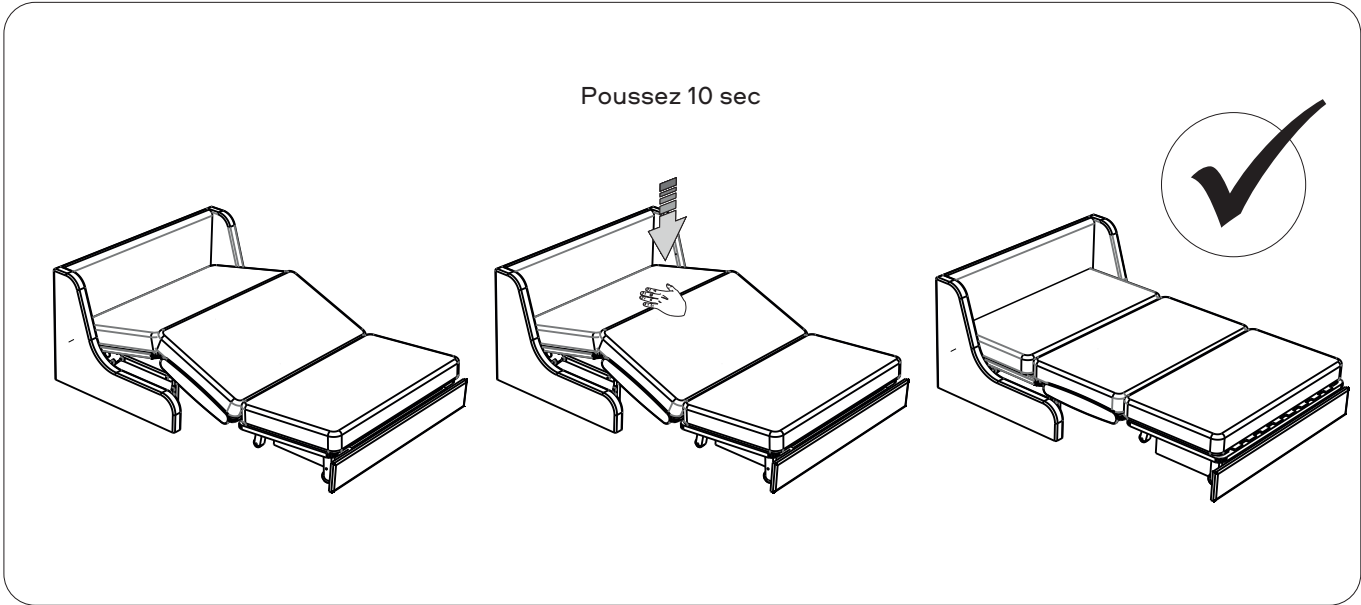





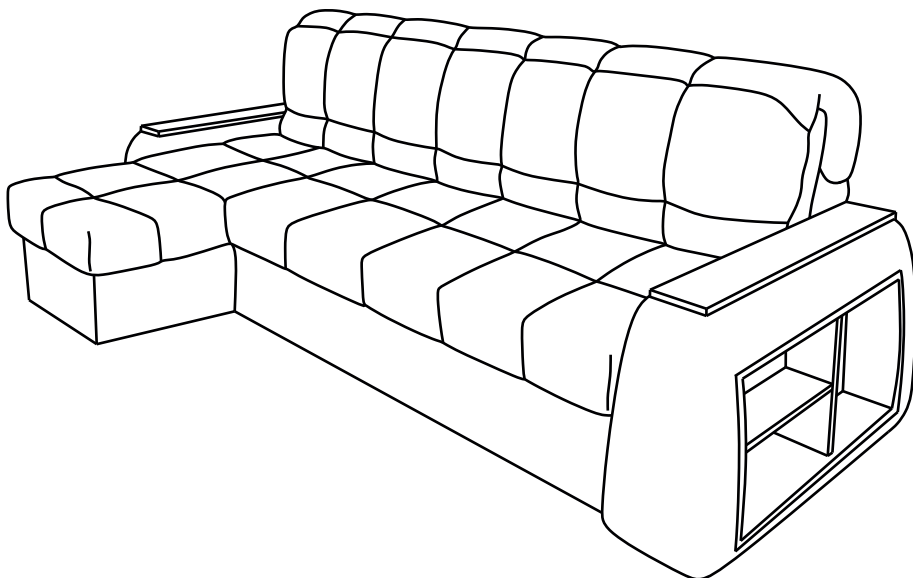
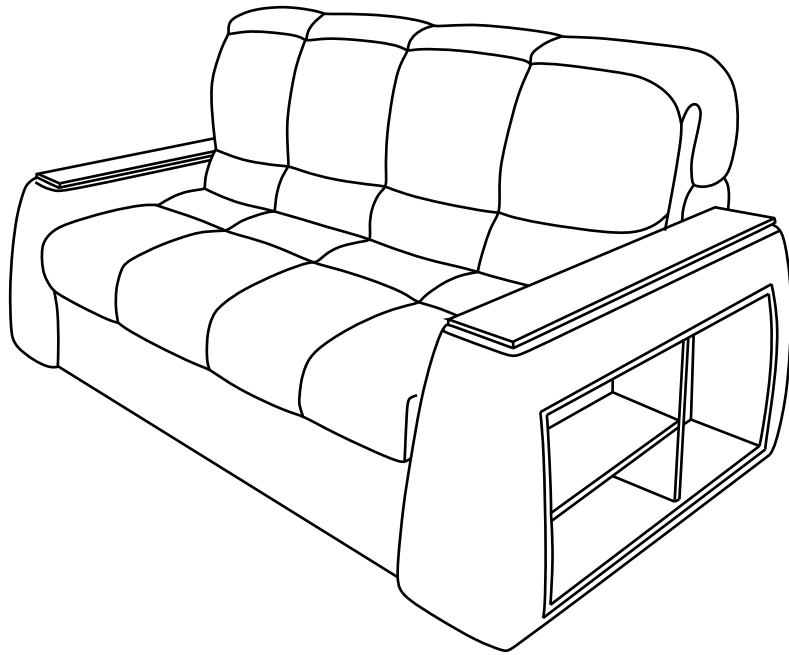



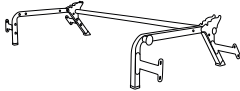

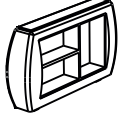
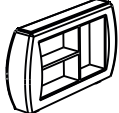
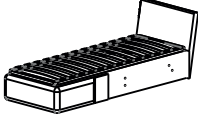

# SUNSET NOVA

HE

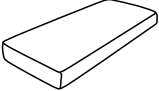

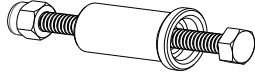
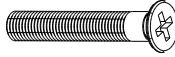
Sleep.8

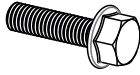
כמות	שם	מק"ט פרטים	ספה / כיסא-מיטת מודול	אריזה
1	מנגנון טרנספורמציה	D01		№ 1
1	תמיכה במנגנון הטרנספורמציה	D26		
1	גב	D04		
1	צ' רגה	D05		
1	מרופד ספה / מיטת כיסא כיסוי, כיסוי בד מדגם	D07		
1	חבילת חומרה			
1	דרכון ספה הוראות הרכבה, בד מדגם			
1	משענת יד	D06		№ 2
1	משענת יד	D06		№ 3
1	קנאפה	D14		№ 4
1	כריות	D11		
1	מרופד ספה / מיטת כיסא כיסוי	D08		
1	חבילת חומרה			
1	דרכון ספה הוראות הרכבה, בד מדגם			
1	מזרן	D20		נרכש בנפרד
1	מזרן	D21		

כמות	שם	מק"ט פרטים	ספה / כיסא-מיטת מודול	אריזה
2	בורג M6x65 תותב פלסטיק (.בקרה עצמית) M6 אגוז	DF02 DF15 DF16		חבילת חומרה
3	בורג-סוטאי M6x30	DF11		
2	קפיץ עם ווים	DF31		
4	בורג M8x45	DF06		
8	בורג M8x30	DF56		
4	מכונת כביסה מוגדלת	DF42		

כמות	שם	מק"ט פרטים	ספה / כיסא-מיטת מודול	אריזה
2	קפיץ עם ווים	DF30		חבילת חומרה
10	בורג M8x80	DF09		
6	עם נעילה עצמית M8 אום	DF19		
14	מכונת כביסה מוגדלת	DF42		
4	מאריך מסגרת קנאפה	DF74		
2	בלם למנגנון	DF75		

## לפני ההרכבה:

- 1) **בדקו את המראה והשלמות של החלקים באריזה!** תביעות בגין נזקים מתקבלות רק עבור מוצרים ללא סימנים של הרכבה.
- 2) **שמרו את האריזה והמדריך עד סיום ההרכבה!** במקרה של גילוי פגם או חוסר חלקים בעת ההרכבה, יש לשמור על האריזה עד הגעת נציג החברה המסחרית.
- 3) **ודאו שמספר החלקים והאביזרים תואם למתואר ברשימה.** היצרן שומר לעצמו את הזכות לבצע שינויי עיצוב במוצר, להחליף אביזרים וחלקי מתכת בפריטים דומים שאינם פוגעים במראה ואינם משפיעים על התכונות התפקודיות של המוצר. במקרה של חוסר חלק או חלק פגום, סמנו את מספר החלק החסר והודיעו לחנות לביצוע החלפתו.
- 4) **שמרו על סדר פעולות ההרכבה המופיע במדריך זה!** הרכבת המוצר או שימוש בו שלא לפי ההוראות יבטלו את אחריות היצרן למוצר.
- 5) **בחרו באזור של רצפה ישרה להרכבת ספה נפתחת למיטה!** גובה לא אחידה של הרצפה או שטיחים עבים עשויים לגרום לסטיות בעבודת מנגנון הפתיחה/הסגירה של הספה הנפתחת למיטה, עיוותים של מסגרת המוצר.
- 6) **בצעו הרכבת ספה נפתחת למיטה בצוותא עם אדם נוסף.** יש להעביר את כל החלקים ממקום למקום בזהירות, בלי לטלטל, להניח אותם ביציבות, להימנע מנפילות וחבלות!
- 7) **העבירו את הרהיט ואת חלקיו תוך כדי הרמה זעירה בלבד.** כך תוכלו למנוע עיוותים ותקלות.
- 8) **הקפידו לשמן את מנגנון ההרמה בעת ההרכבה בהתאם להוראות!** כך תוכלו למנוע חריקה מוקדמת של המנגנון. חזרו על השימון והדקו ברגים ואומים הרופפים בצורה בולטת פעם בחצי שנה לכל הפחות.

## להרכבה תצטרכו:

	מברג צלב
	מפתח ברגים מס' 13 x 2 מפתח ברגים מס' 10 x 1
	מגבת נייר
	חומר סיכה בתרסיס סיליקון
	מספריים
	רולטה

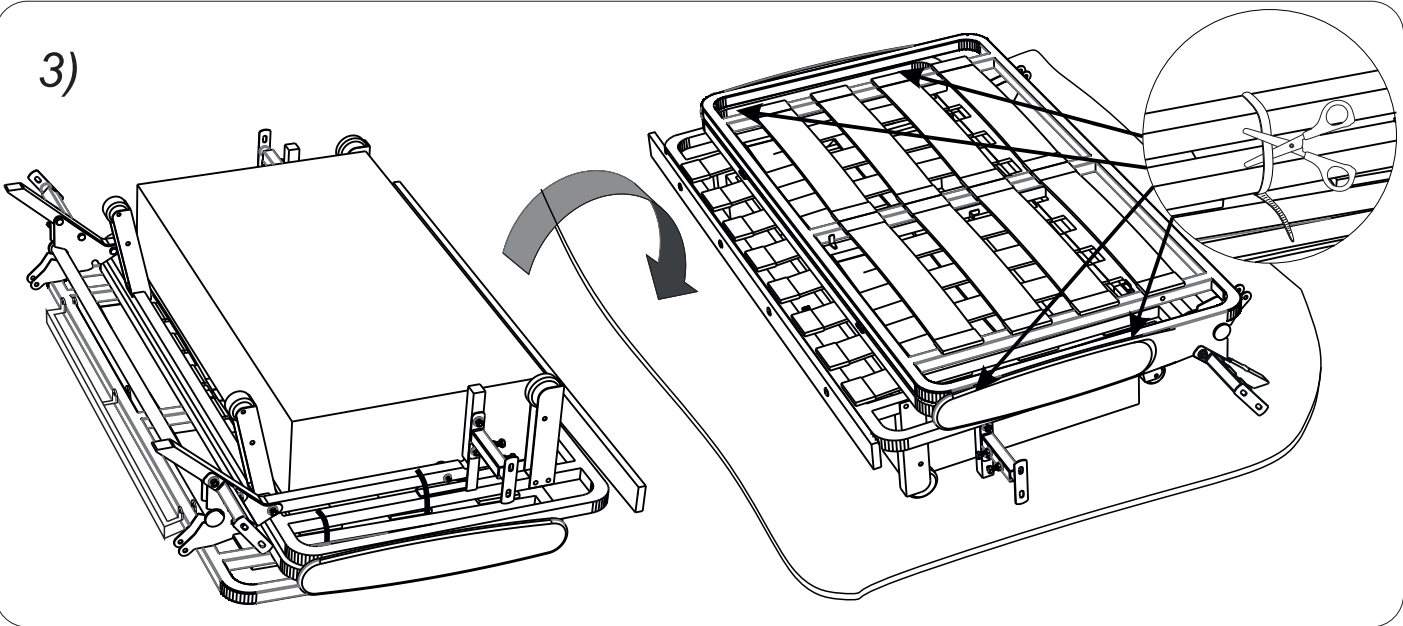
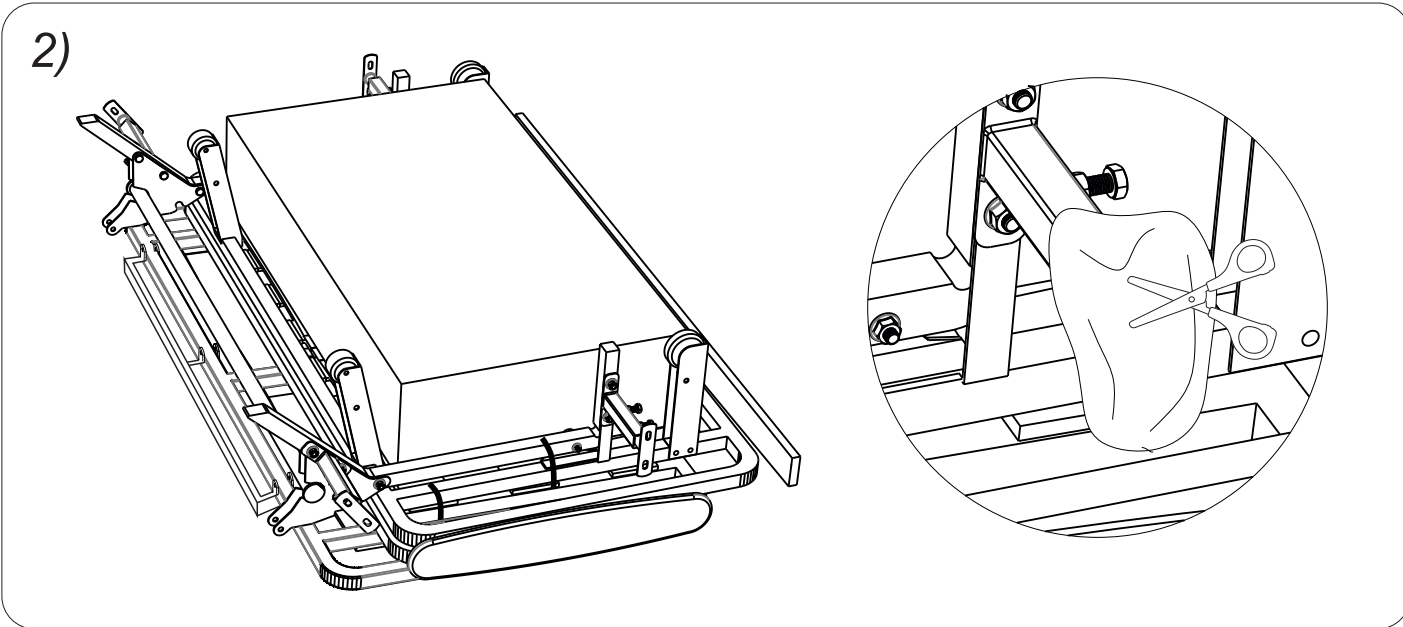
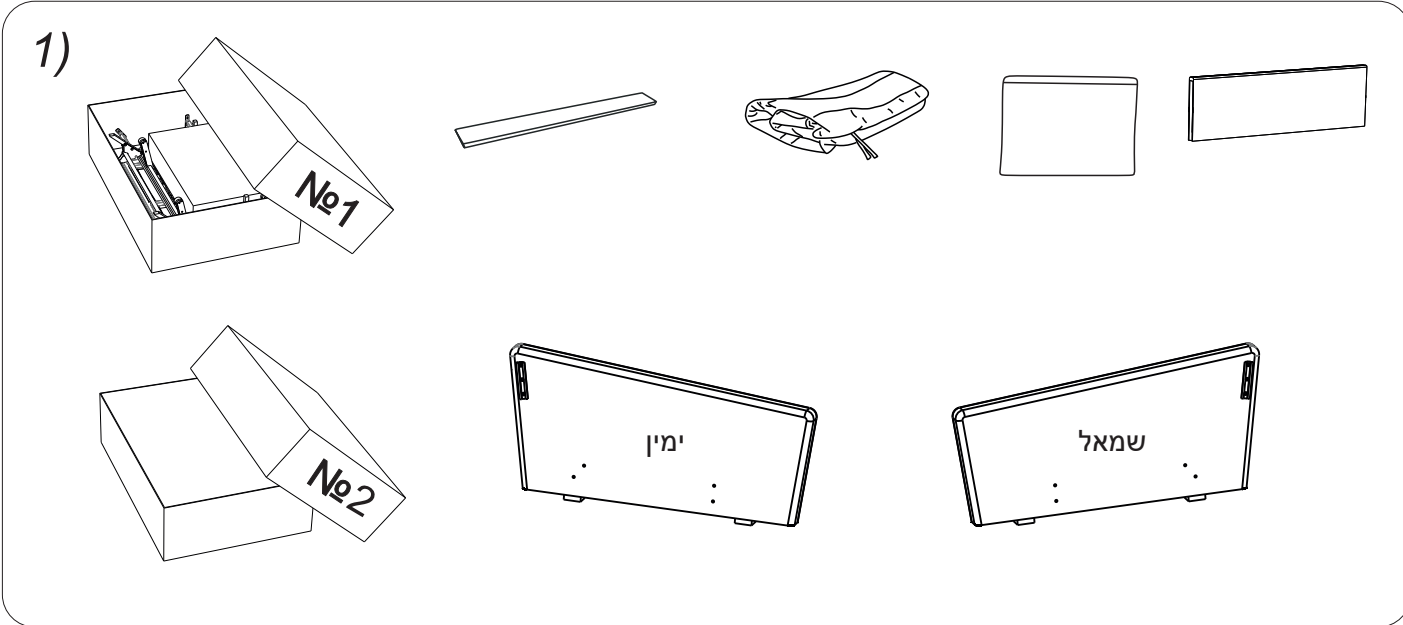



4)

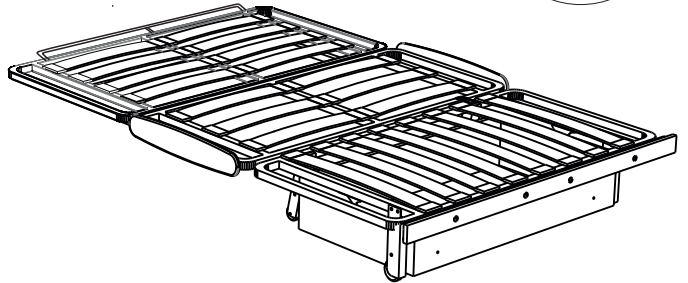
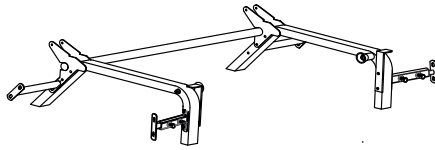
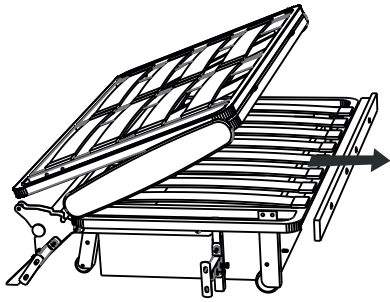

הסר את המסגרת מהבסיס

5)

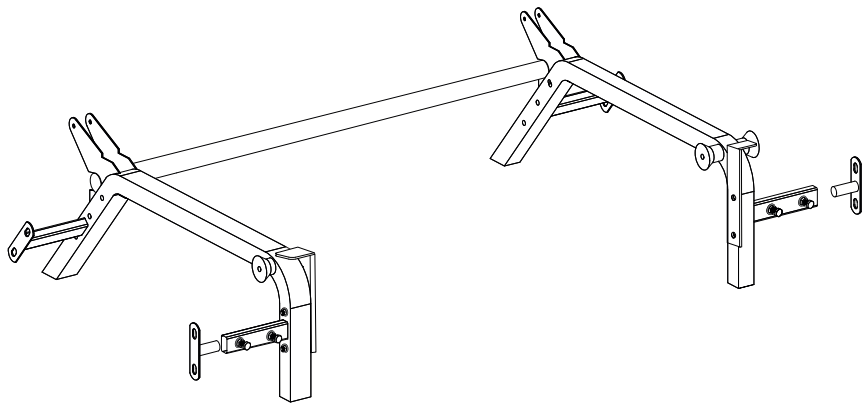
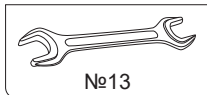
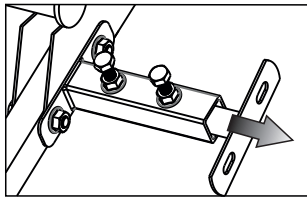
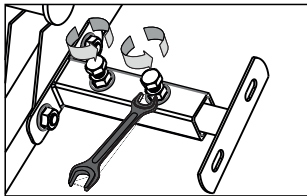

6)

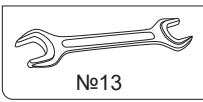
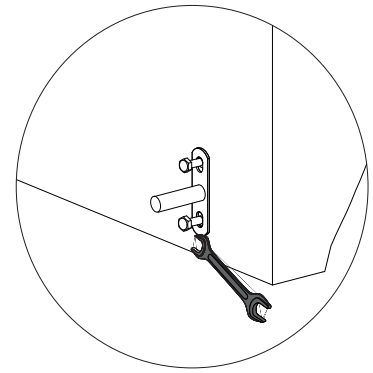
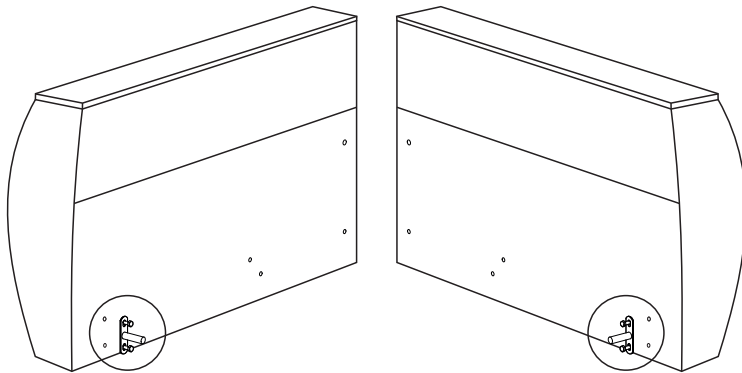

בעת הרכבת ספה פינתית, התקן את התושבת על משענת יד אחת  
(בצד שמול הקנפה)

7)

ברגים בסוגריים לא להדק

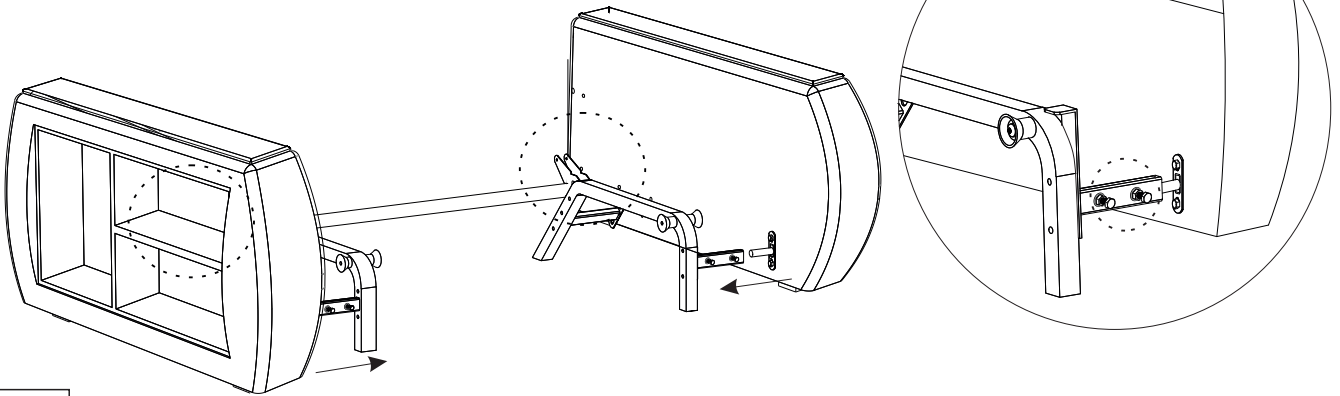

הברג את הסוגריים האחוריים  
ברגים בסוגריים הקדמיים לא להדק

8)

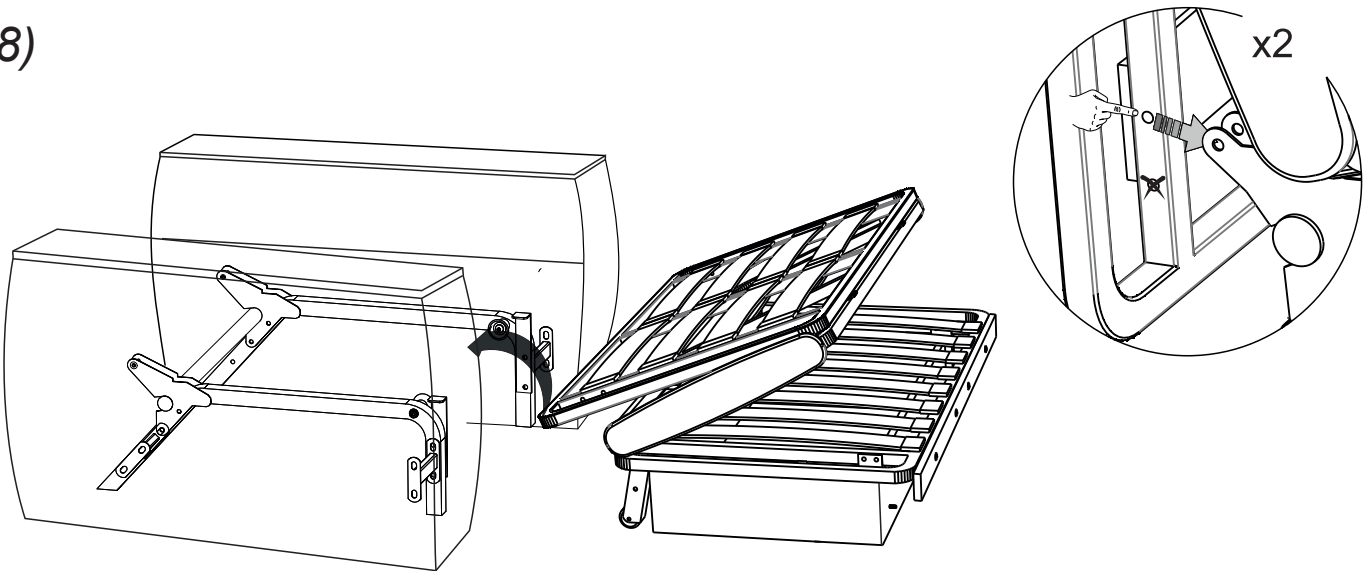

מאוד לא להדק

9)

x2

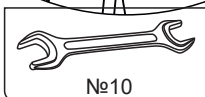
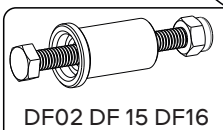
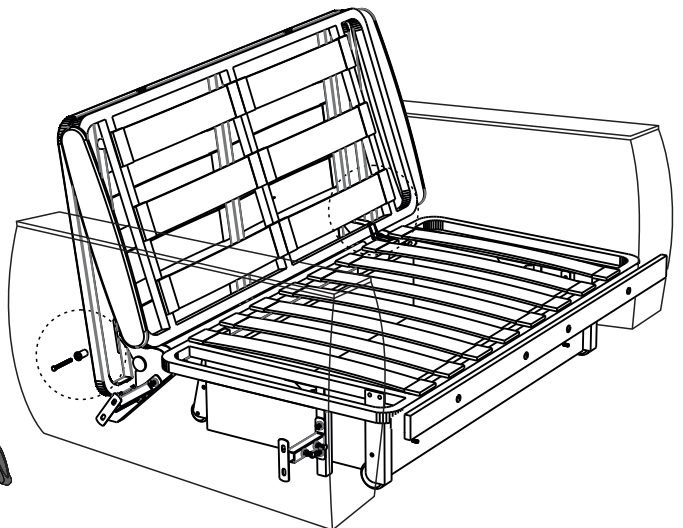
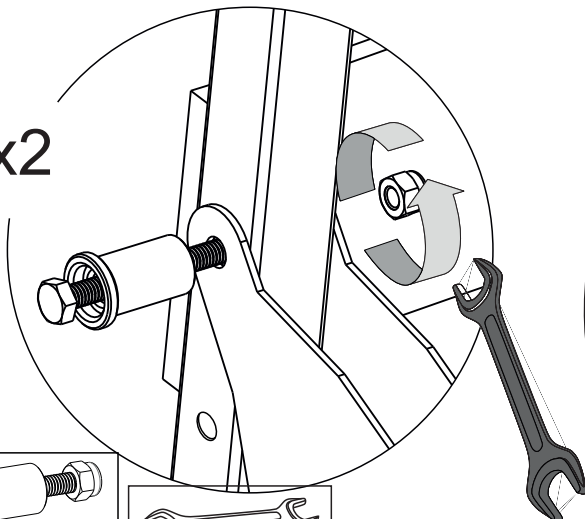

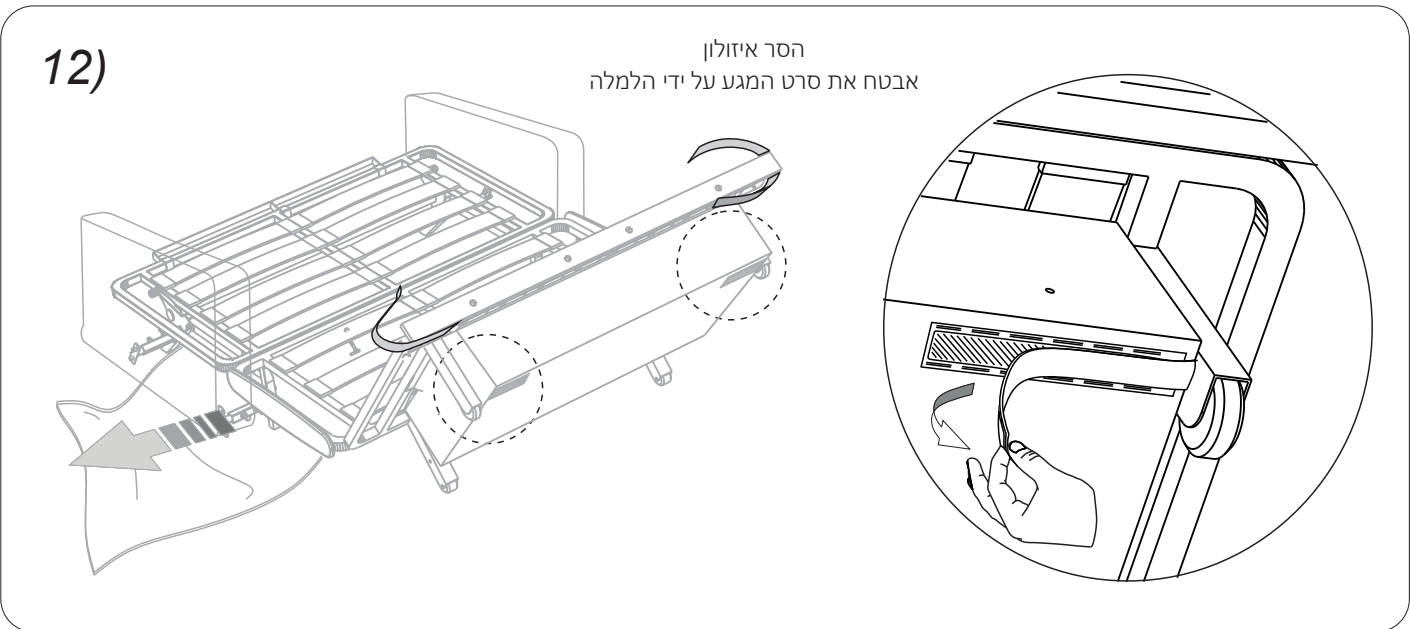
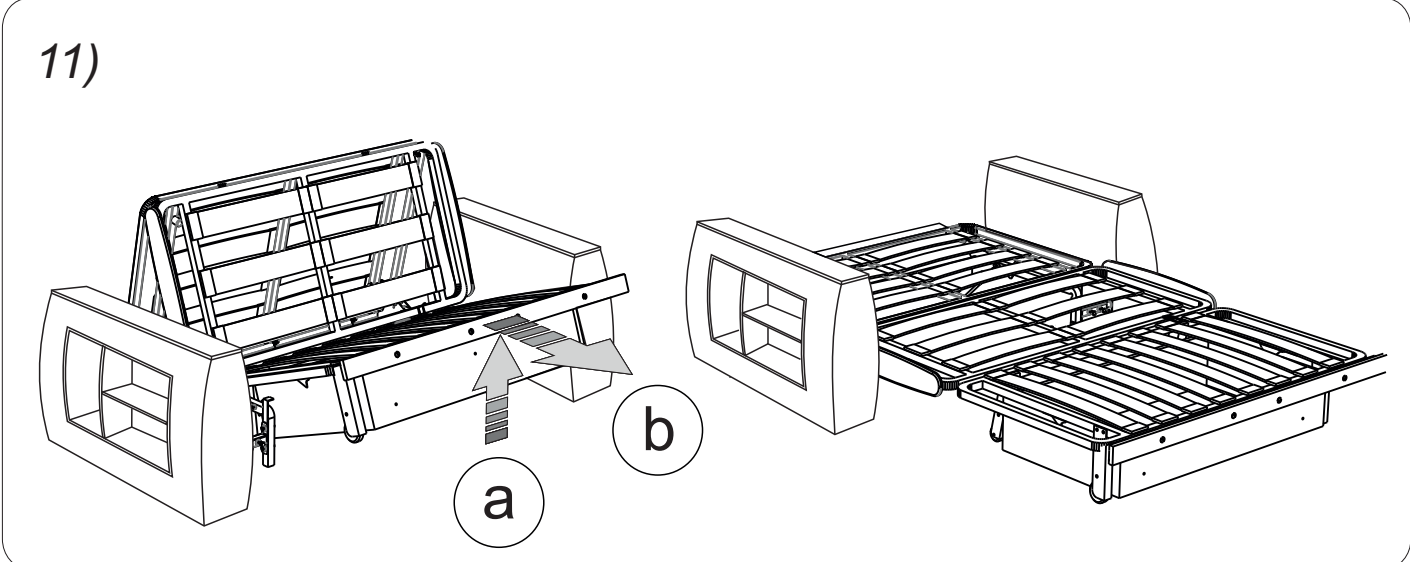
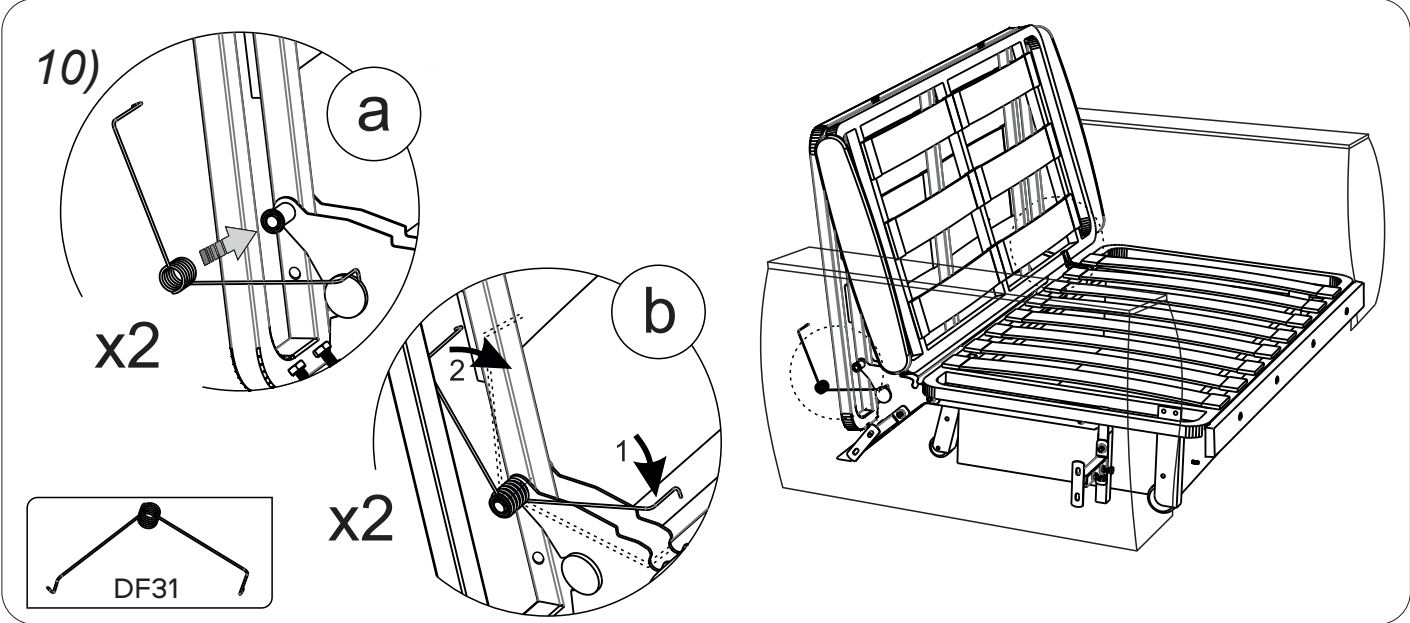

13)

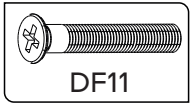
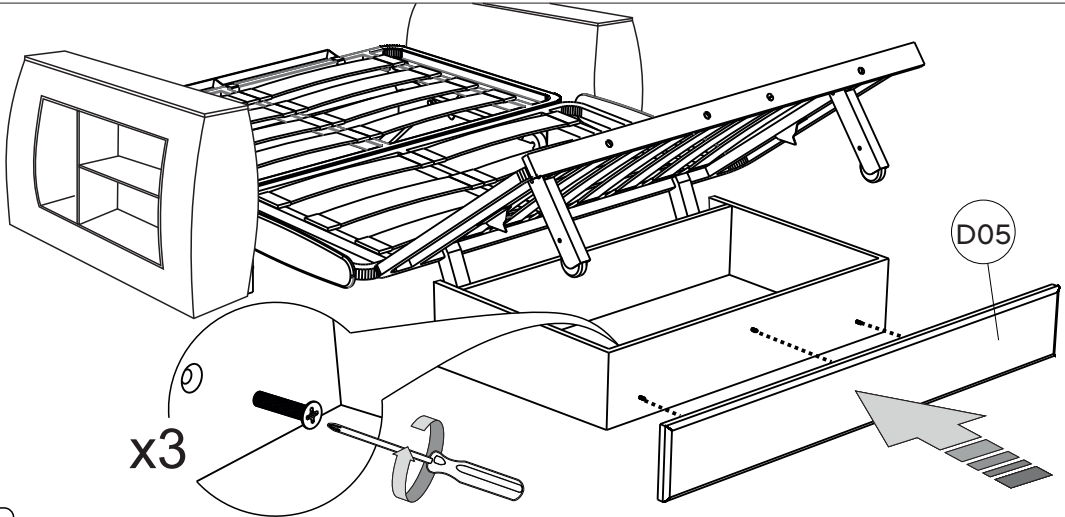

החלק התחתון של הצארגי נקבע על ידי נוכחות של רצועת סיכות

14)

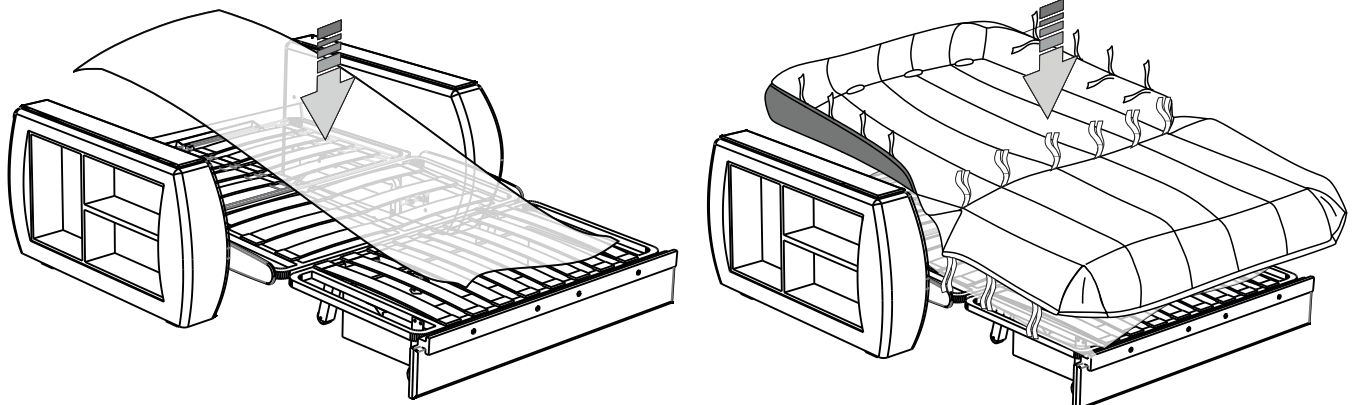

הניחו את הסרט מאריזת הספה על המנגנון כדי להגן על הכיסוי מפני שימון

15)

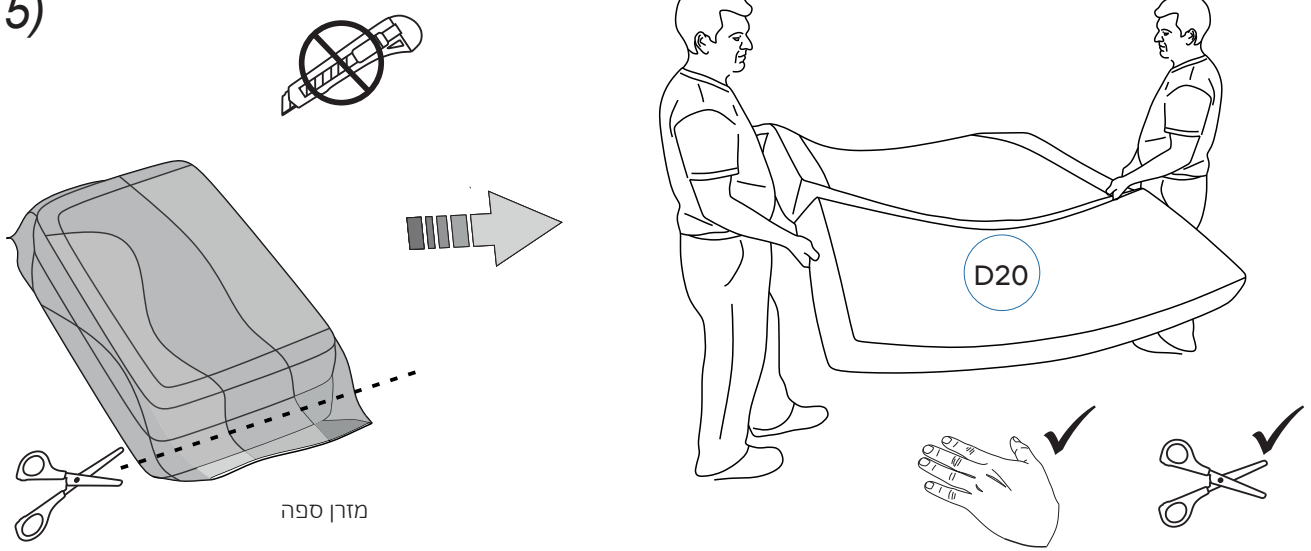

מזרן ספה

16)

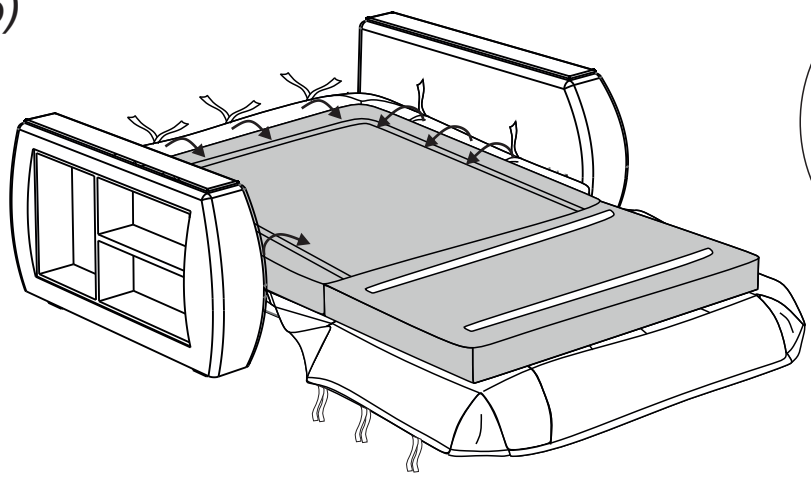

יישר את התפרים והפינות של המזרן והכיסוי  
בראש המיטה, השחילו את סרטי המגע לחורים בכיסוי

17)

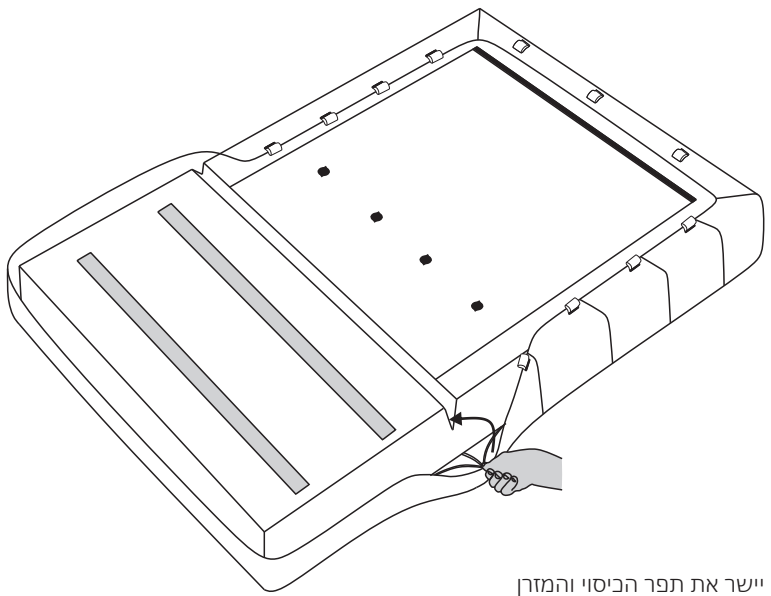

יישר את תפר הכיסוי והמזרן

18)

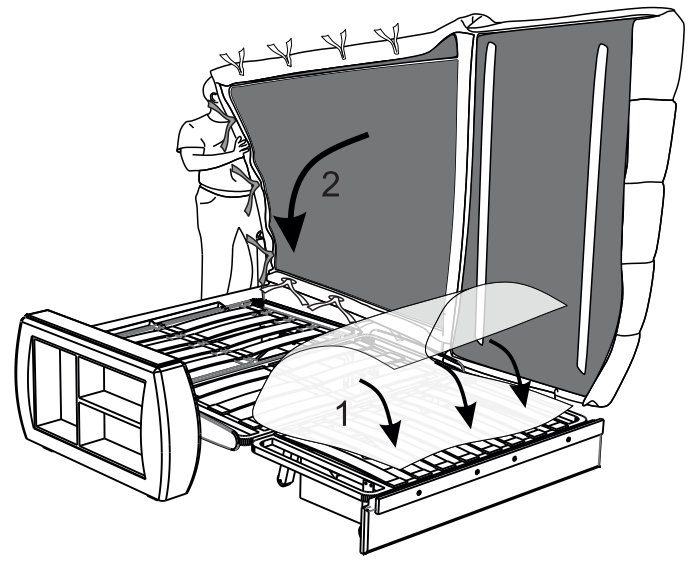



19)

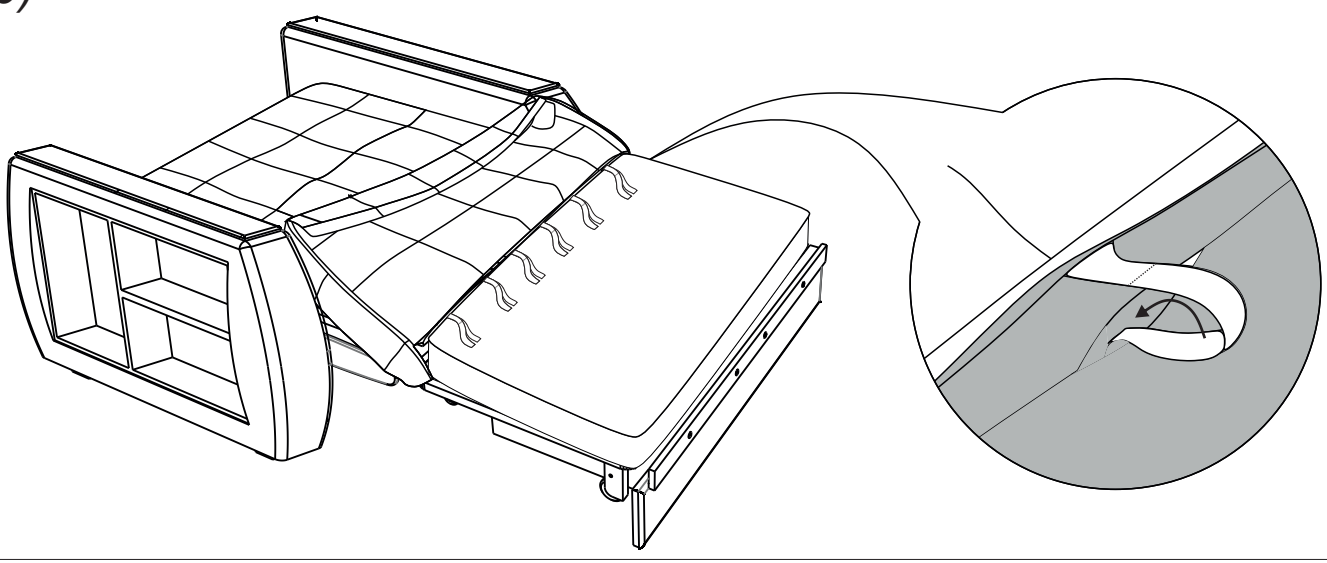

20)

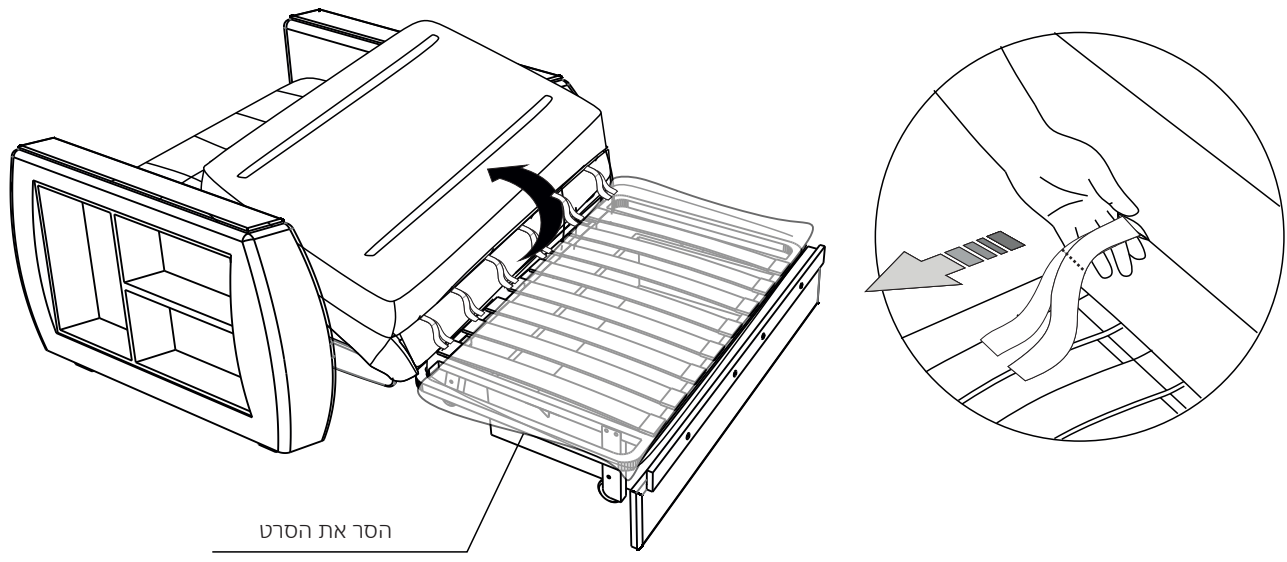

21)

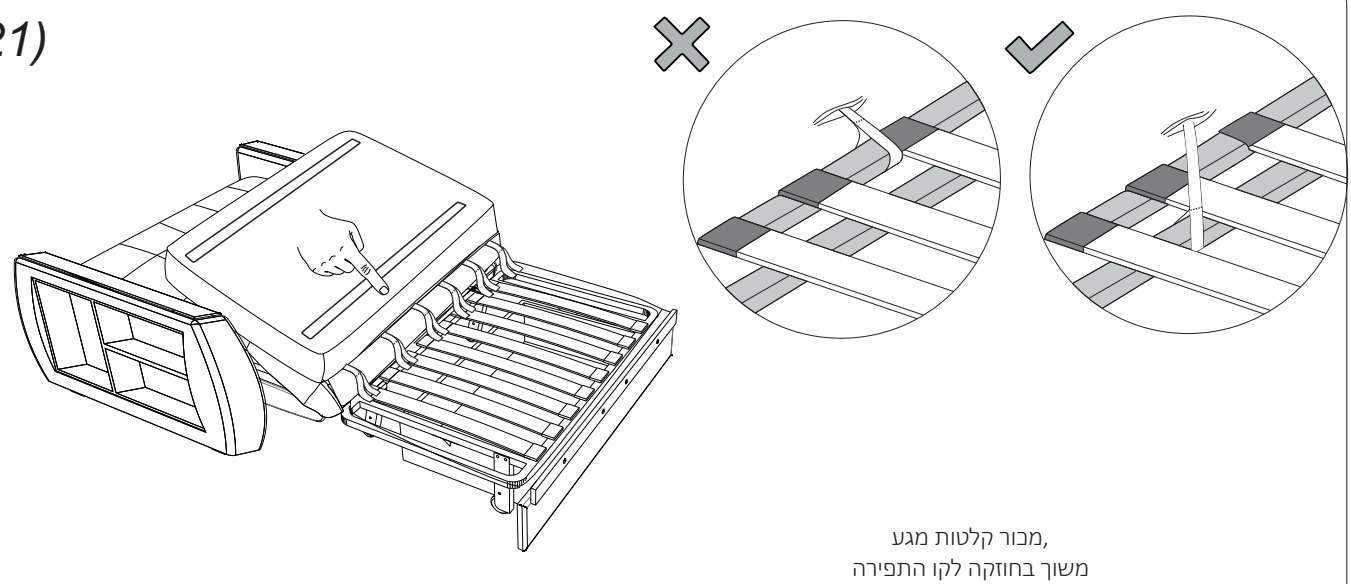

מכור קלטות מגע,  
משוך בחוזקה לקו התפירה

22)

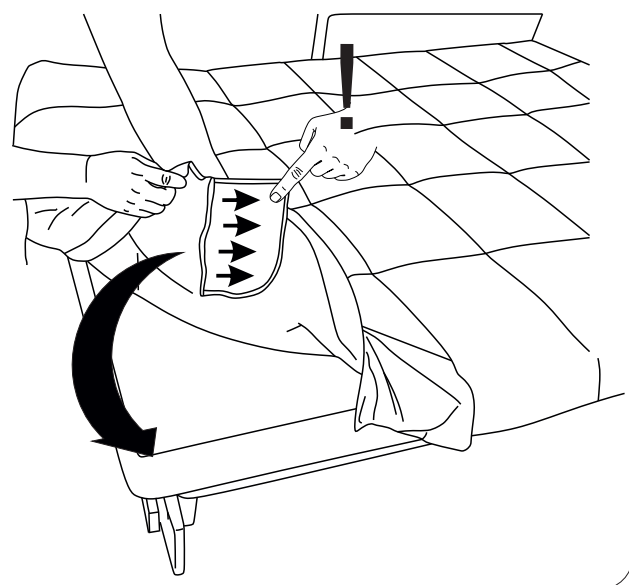
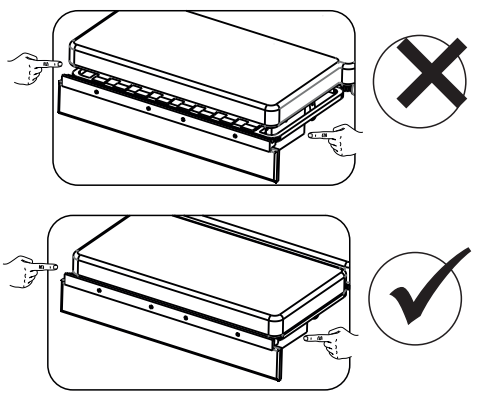

המזרון צריך לבלוט מעבר לקצה המעקה לא יותר מ-1 ס"מ

23)

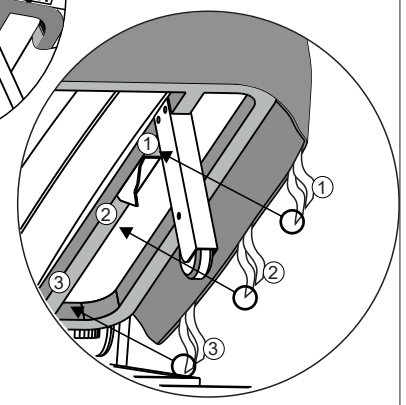
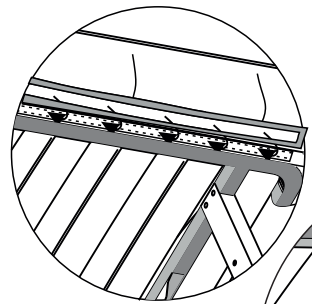
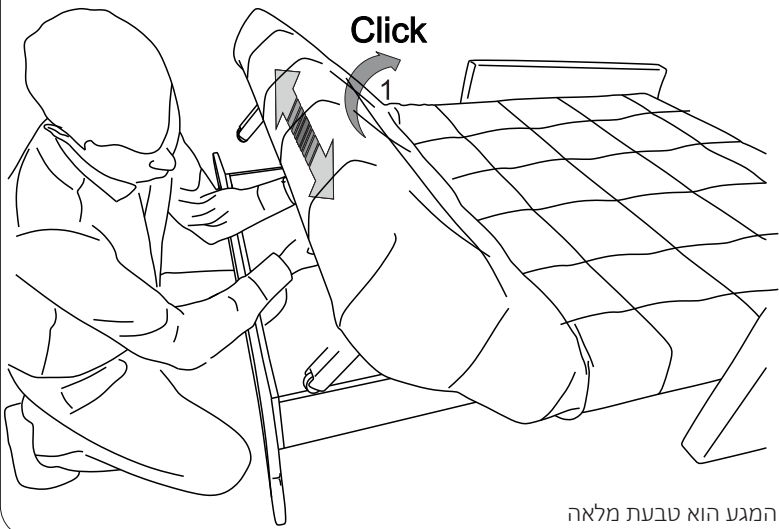

הייקף סרט המגע הוא טבעת מלאה

24)

אסוף את הכיסוי העודף במקום הקיפול של המזרון כדי להקל על השינוי

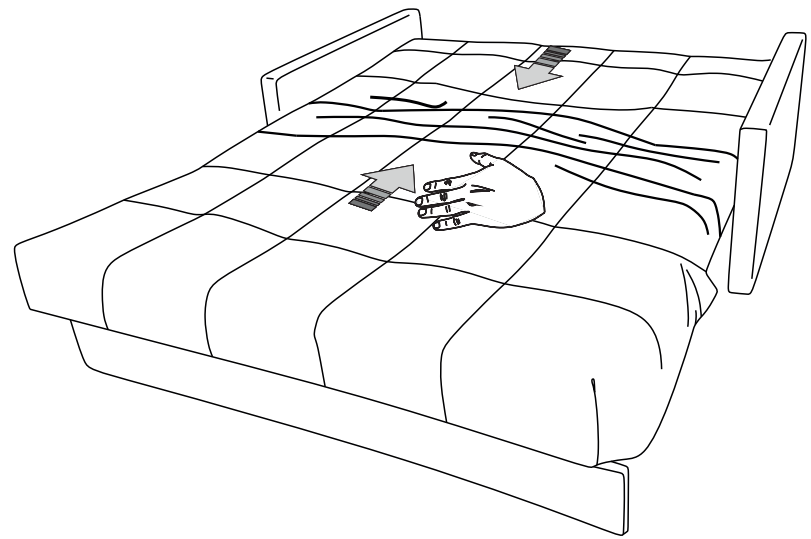



25)

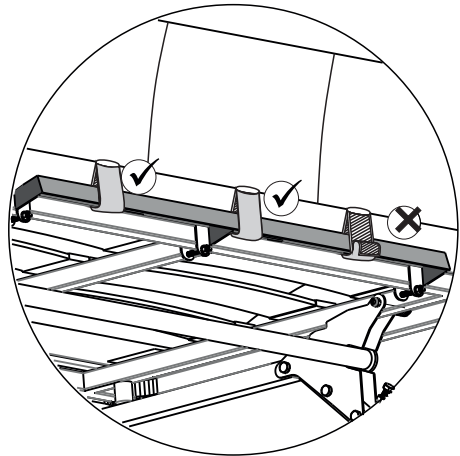
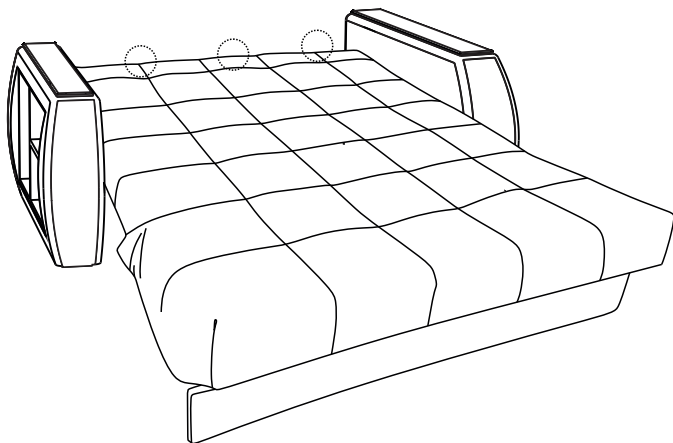

26)

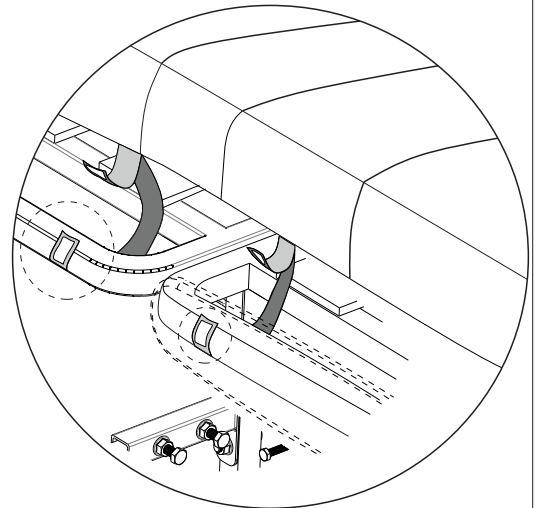
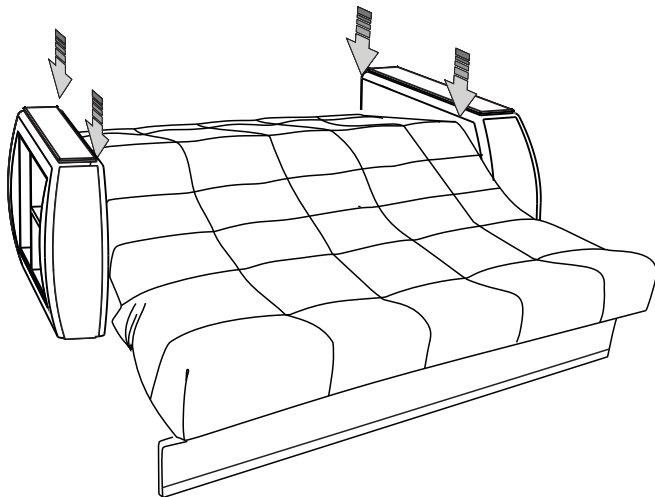

העבר את הספה למצב פרוש למחצה  
בעת קיבוע, קלטות המגע צריכות להיות מהודקות ככל האפשר

27)

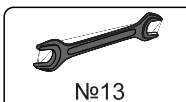
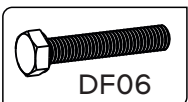
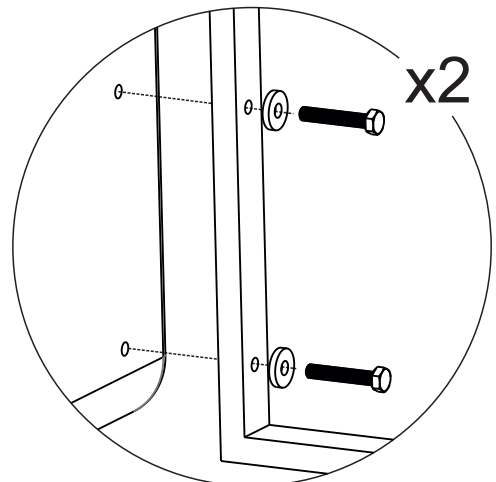
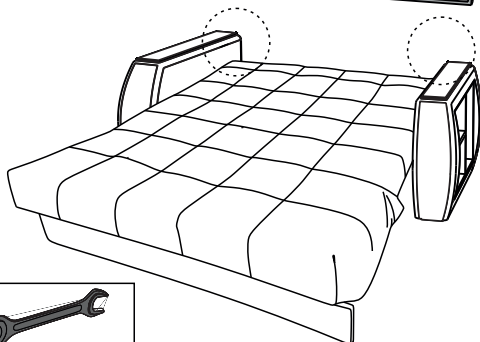
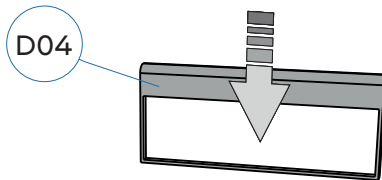

28)

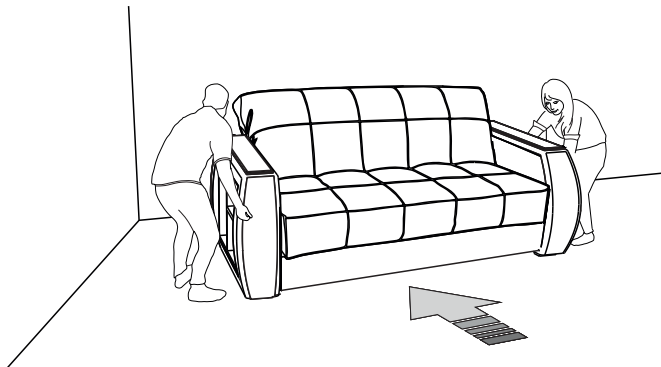

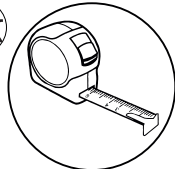
$A \approx B$  OK 

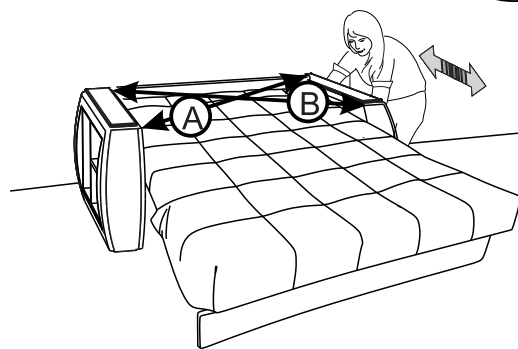

התקן ספה במקום הפעלה קבוע

29)

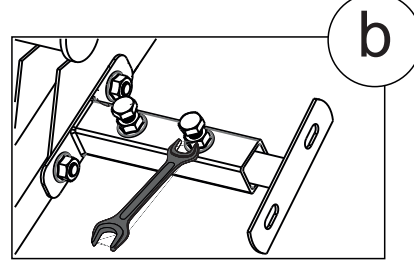
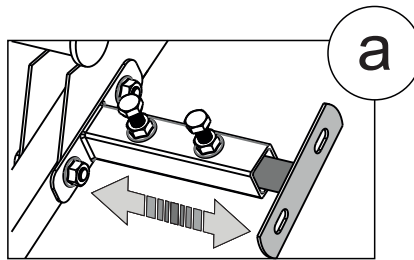
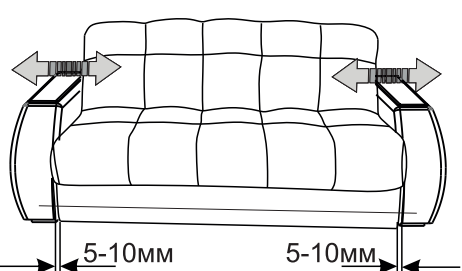

להדק

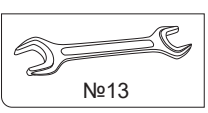

30)

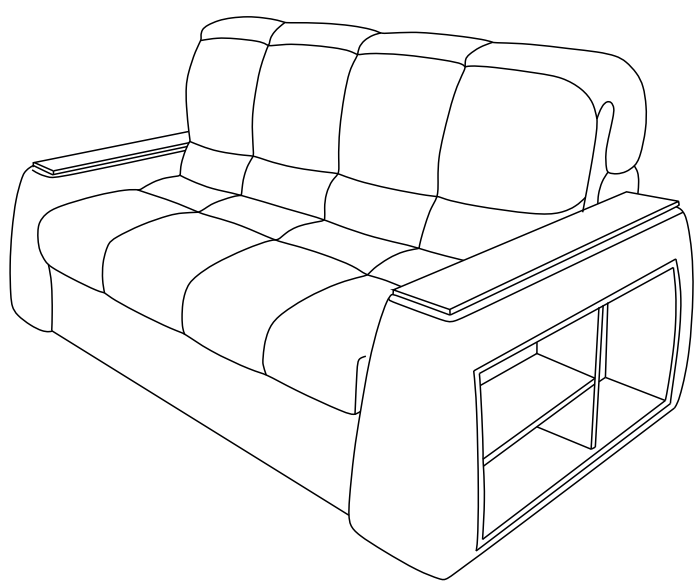

הרכבת ספה פינתית

31)

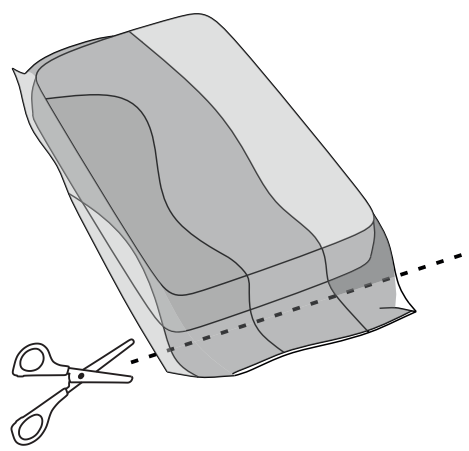
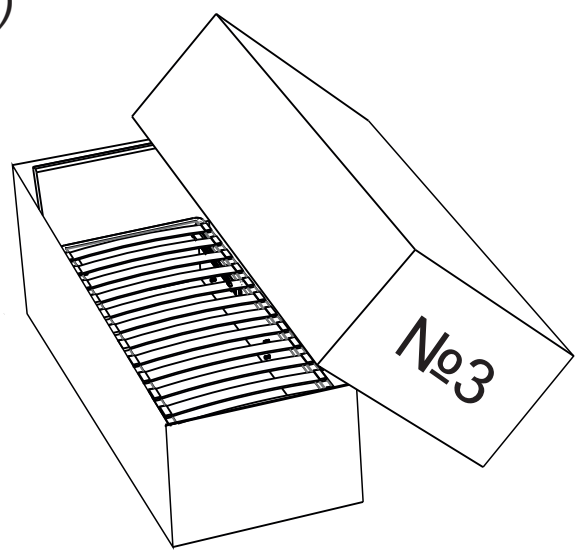

32

בעת רכישת פוף, התקן את מנגנון ההתקשרות על הקנפה (הוראות הרכבה וחומרה מסודרים באריזה עם פוף)

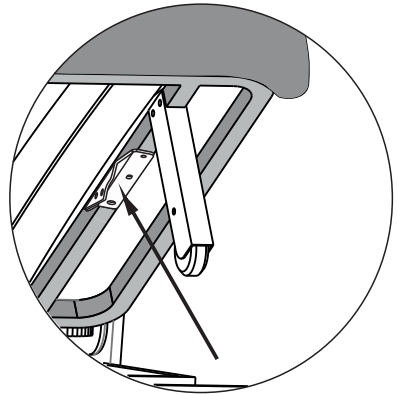
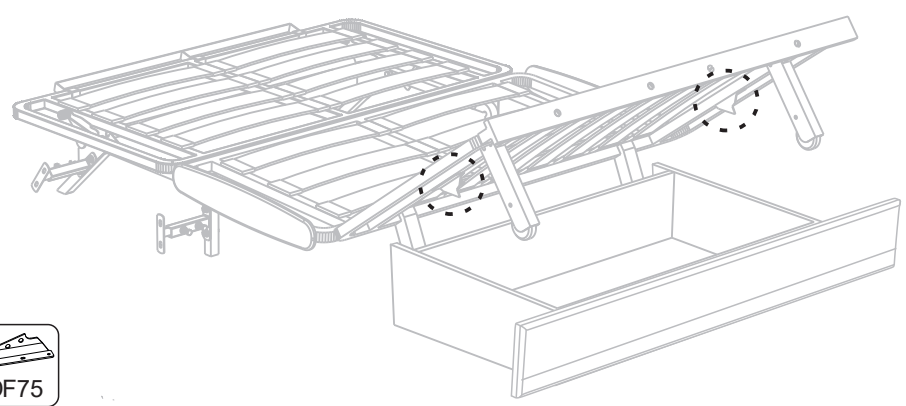

33)

קפיצים מותקנים רק על קנפה קטנה

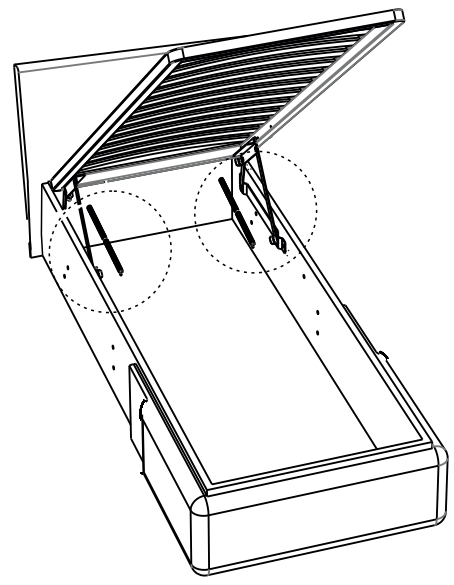
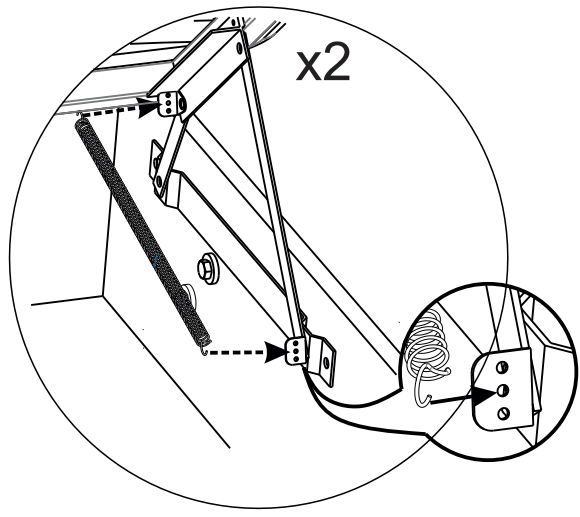

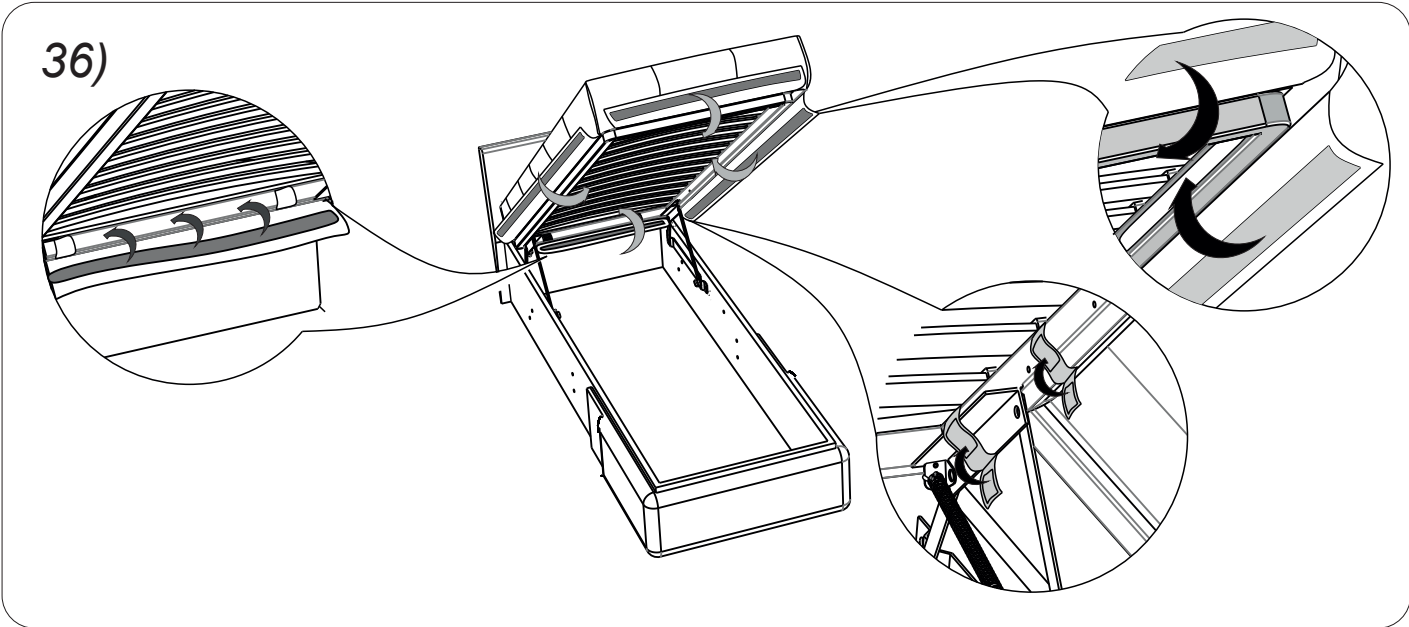
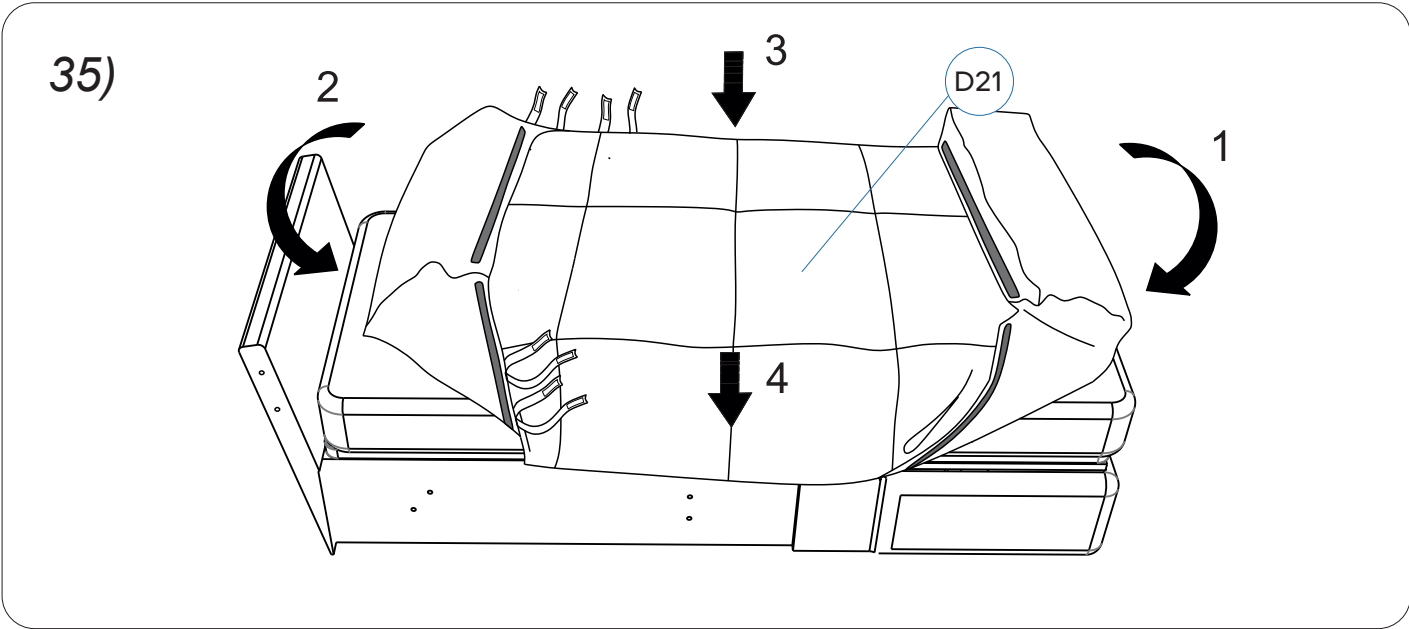
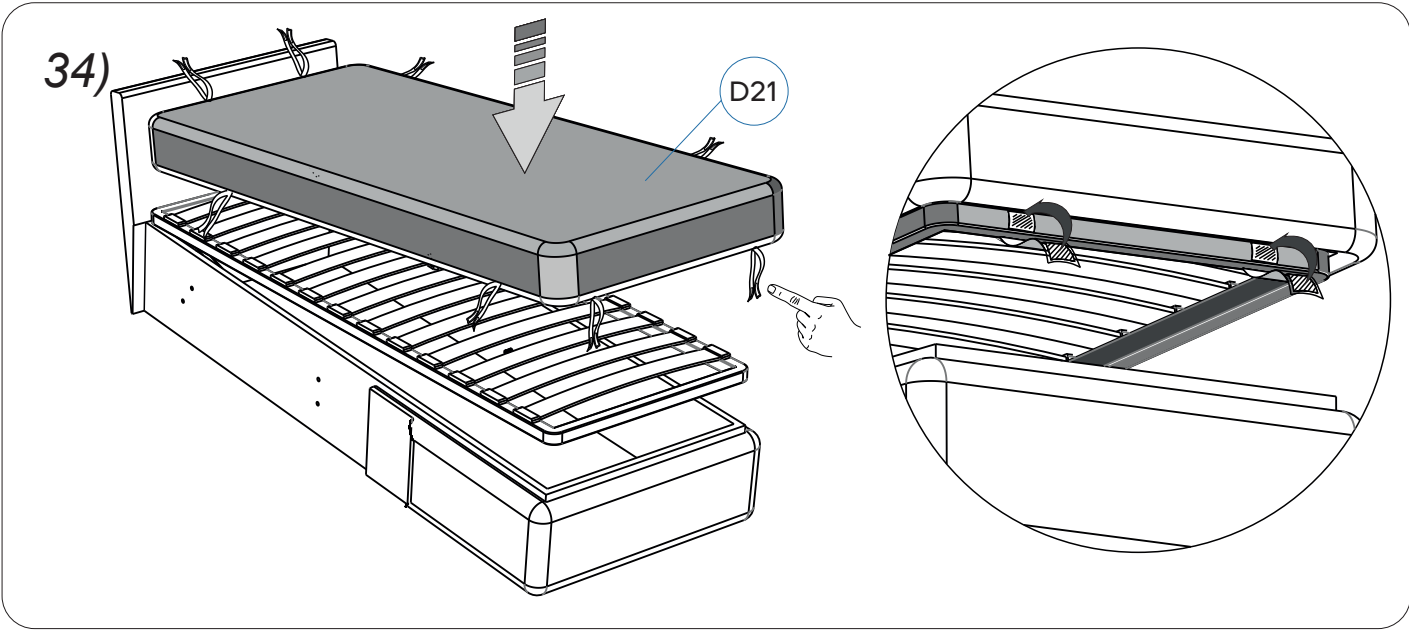

37)

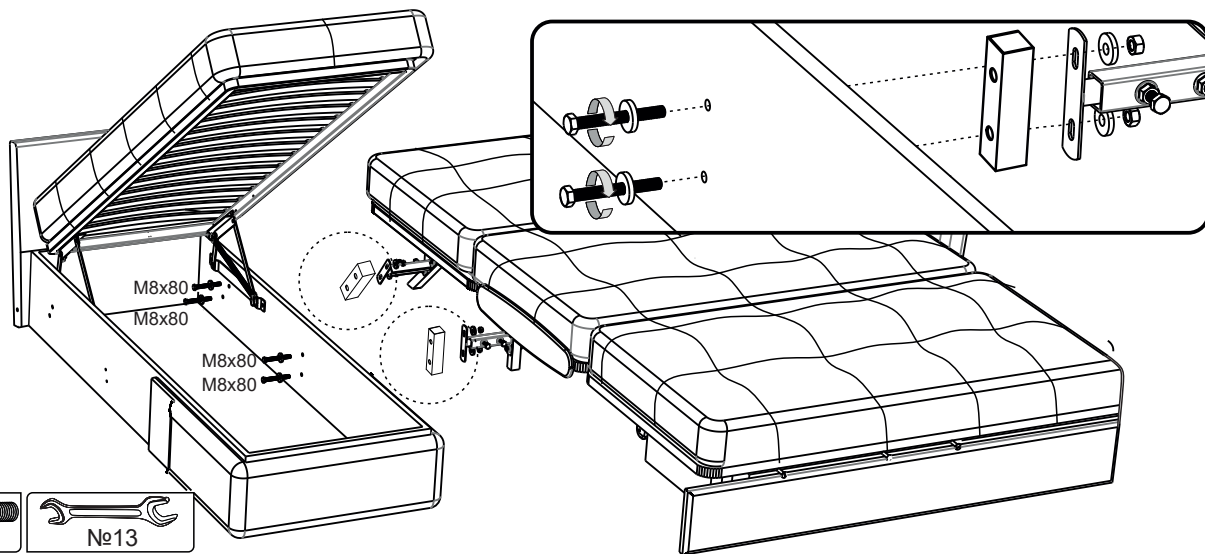

38)

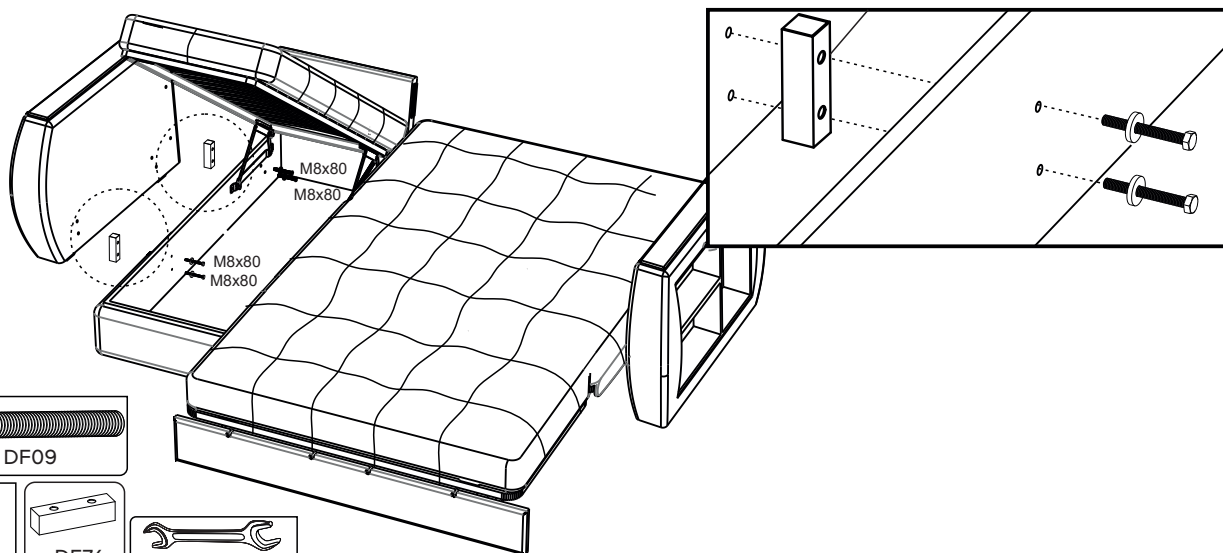

39)

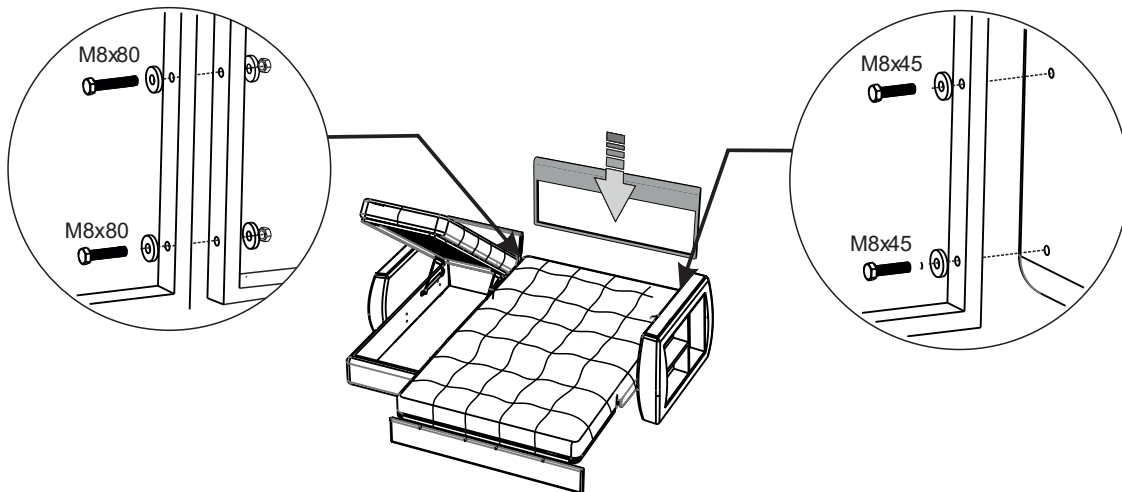

40)

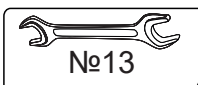
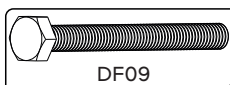
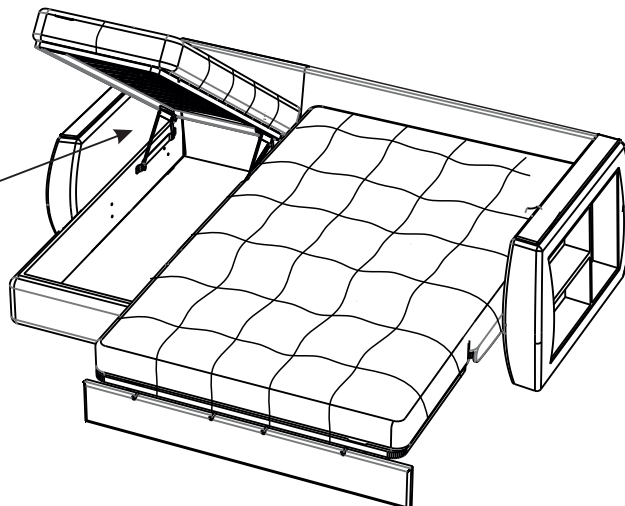
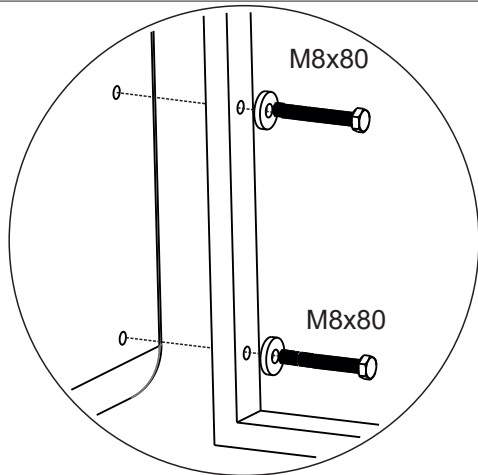

41)

1

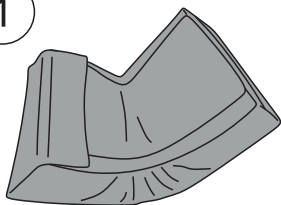

2

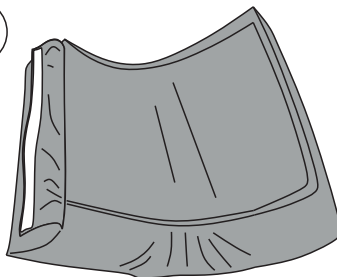

3

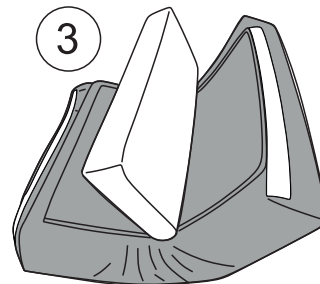

4

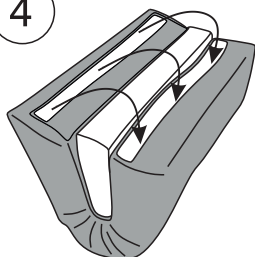

5

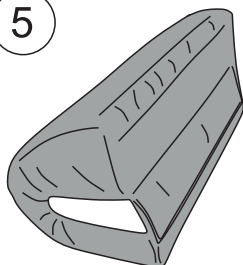

6

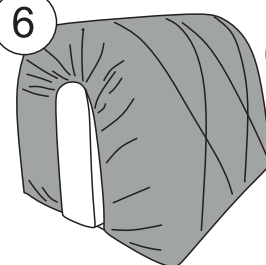

42)

b

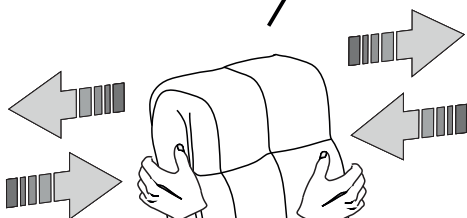

a

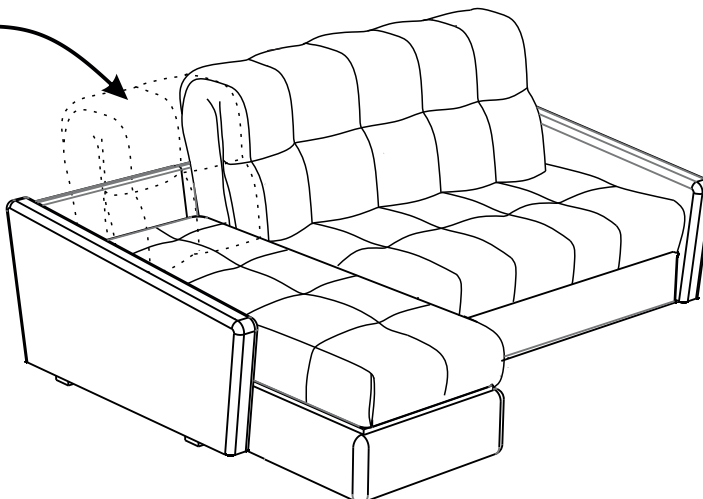



43)

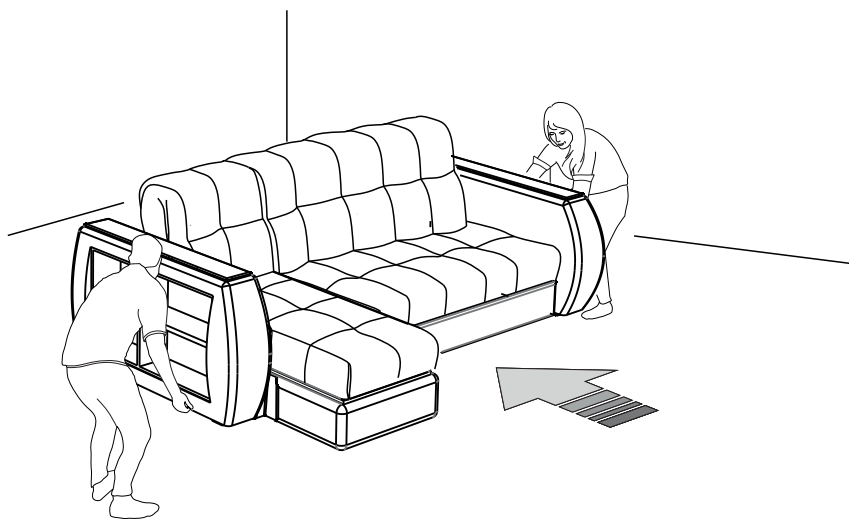

התקן ספה במקום הפעלה קבוע

44)

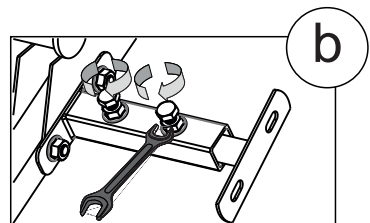
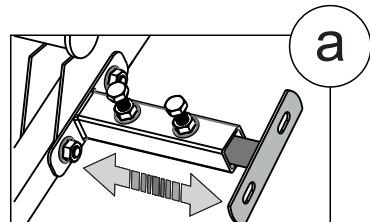
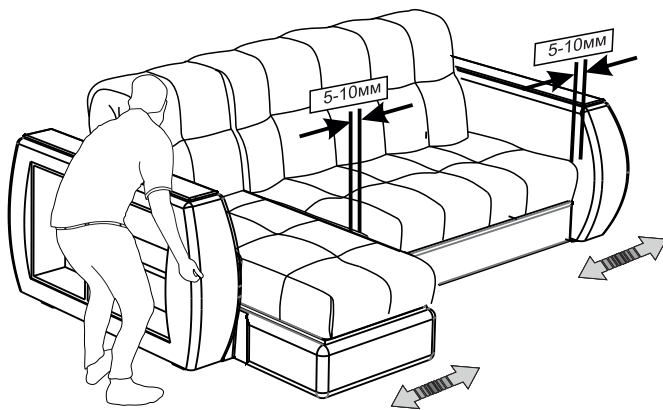

להדק



45)

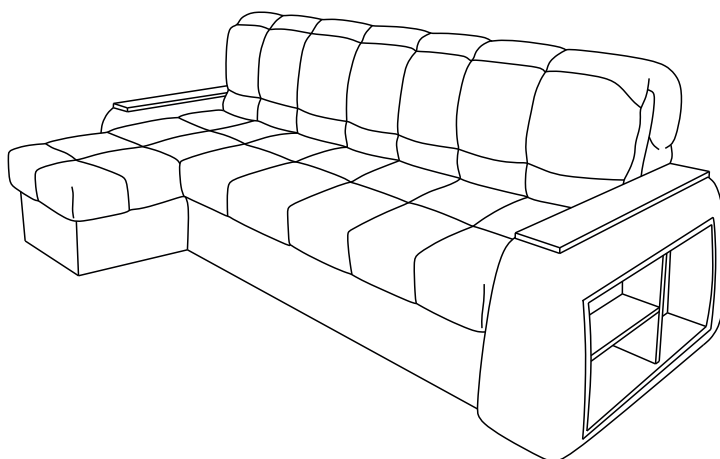



סדר שינוי הספה

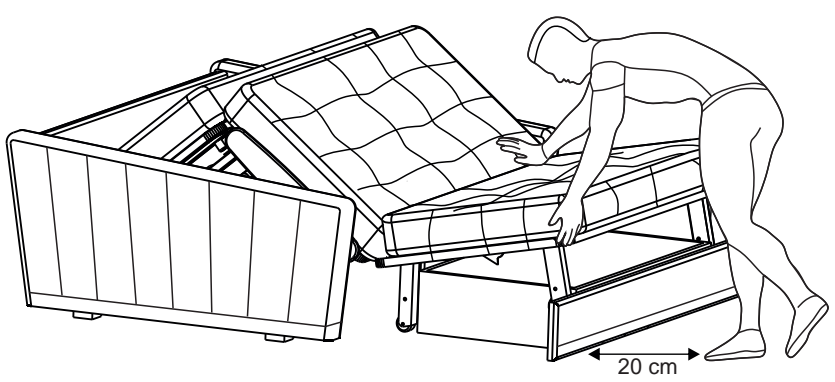
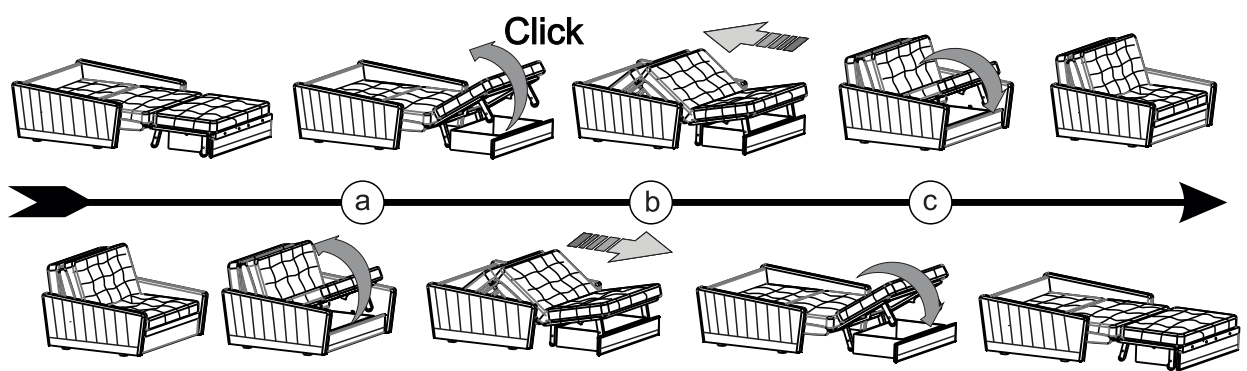

אם מושב הספה אינו עולה, הסר את רצועות הוולקרו למשלוח

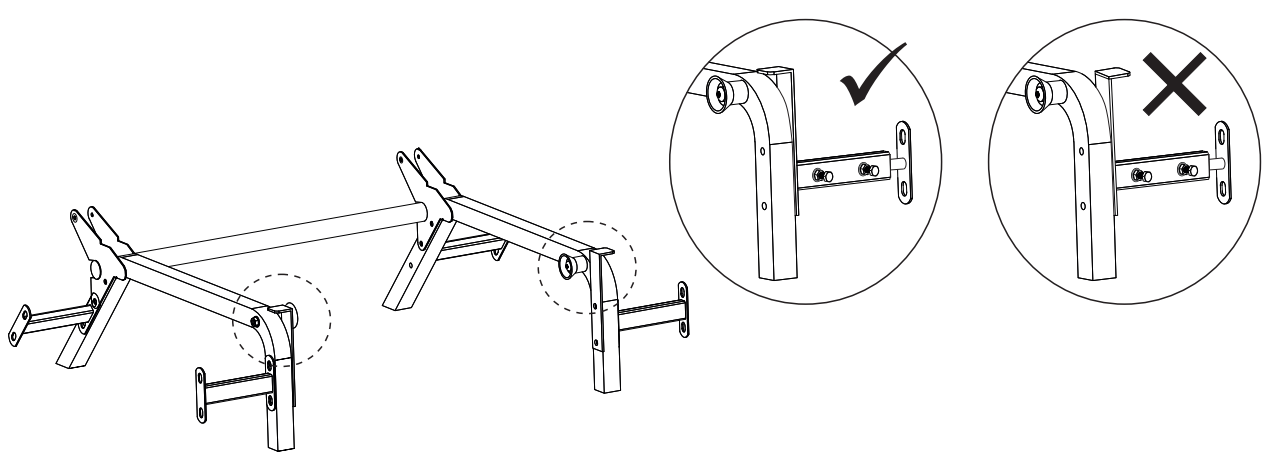

אם מושב הספה אינו זז, בדוק את מיקום התומכים במגננון

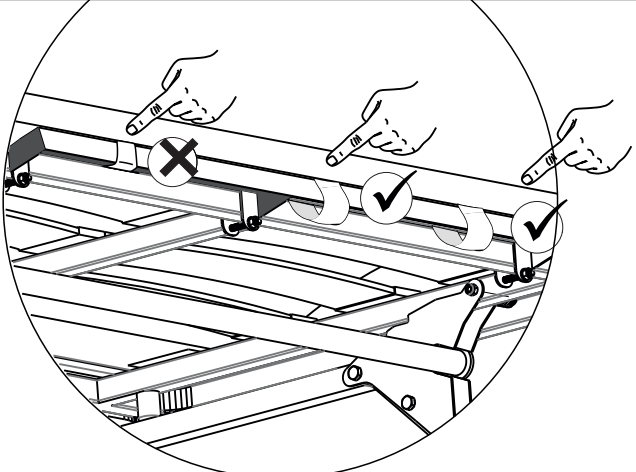
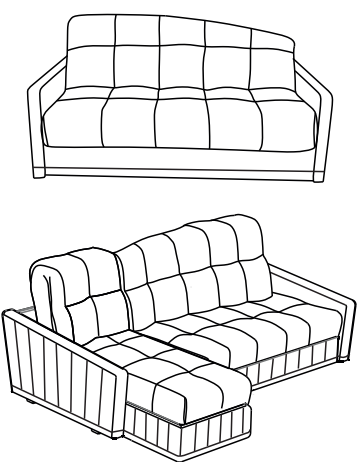

בעת כיפוף גב הספה, שחרר את רצועות המגע בראש המיטה

אם יש פער גדול בין המזרן למשענת היד, הרם את אזור המושב ושחרר את רצועות המגע

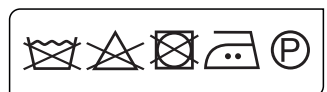
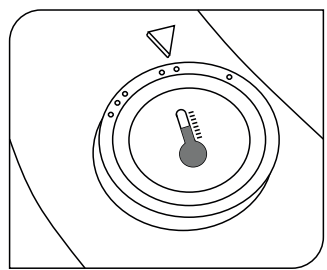
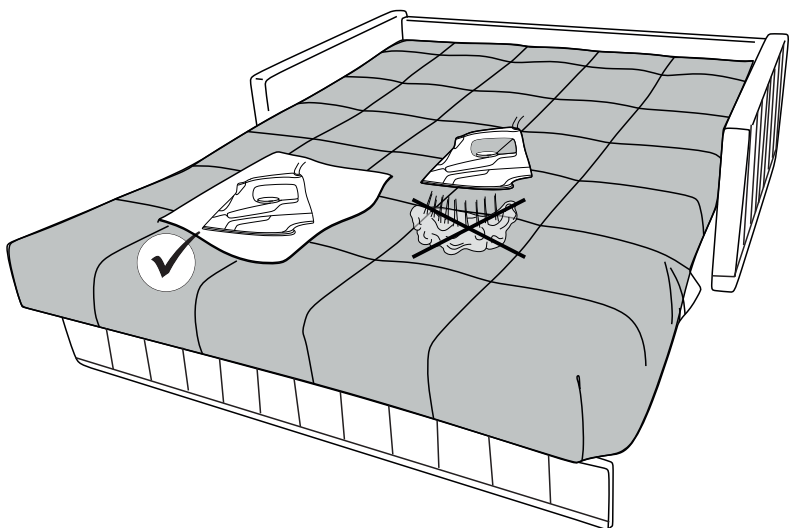
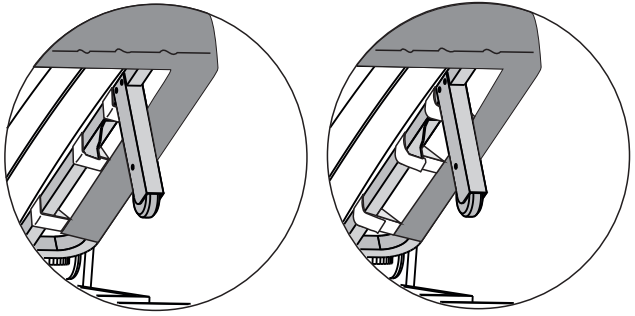
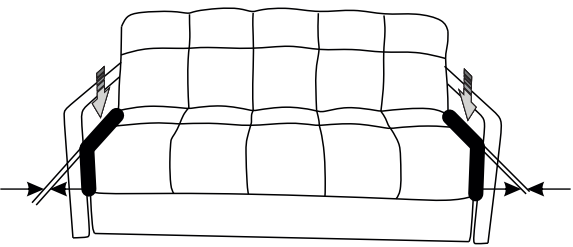
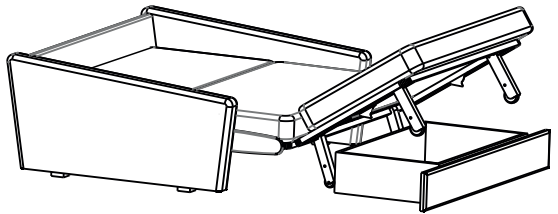

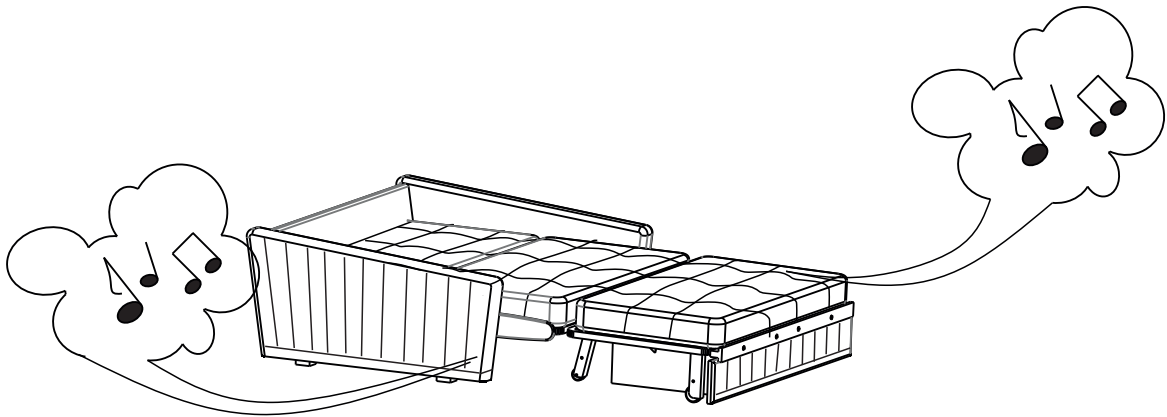

זכור: החריקה האופיינית של אלמנטים מתכתיים של המנגנון תחת טרנספורמציה מתמדת היא מצב נורמלי. בלב הספה יש מבנה מתכת במהלך הטרנספורמציה והניצול, חומר הסיכה בין הצמתים השונים של המנגנון יכול להתייבש ומופיע חיכוך של אלמנטים מתכתיים זה בזה. כדי למנוע את המראה של חיכוך זה ואת החריקה של המנגנון במהלך טרנספורמציה או ניצול, חשוב לעקוב אחר ההמלצות הבאות: אם מתרחשת חריקה, יש לשמן את האלמנטים המשפשפים של המנגנון, למתוח את החיבורים. בצע שימון לפחות פעם אחת בכל 6 חודשים.

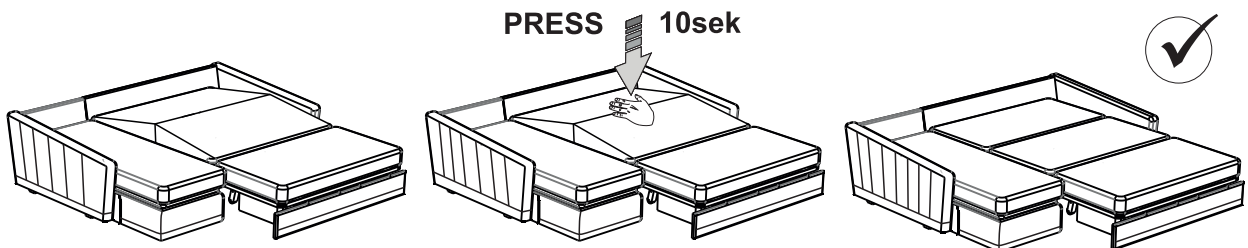
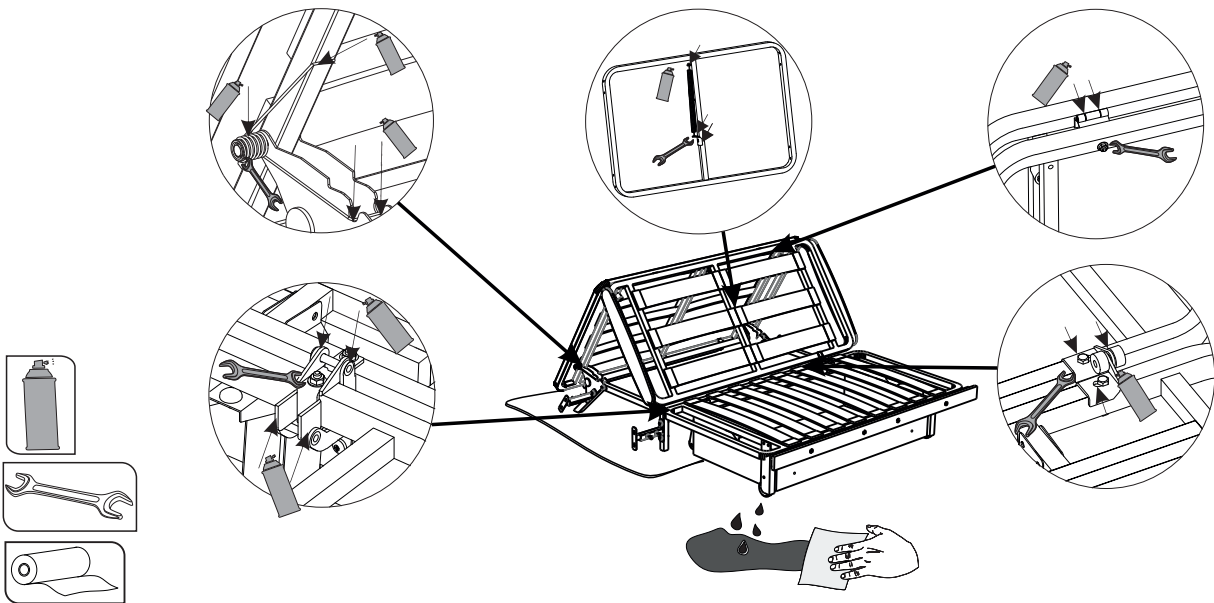

לחץ על 10 שניות

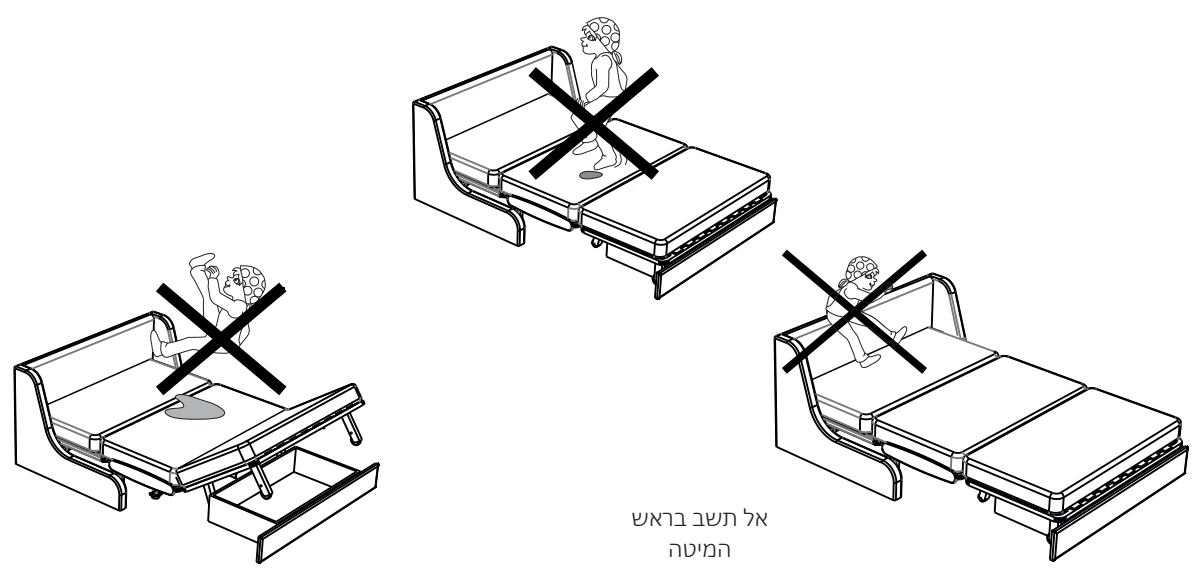
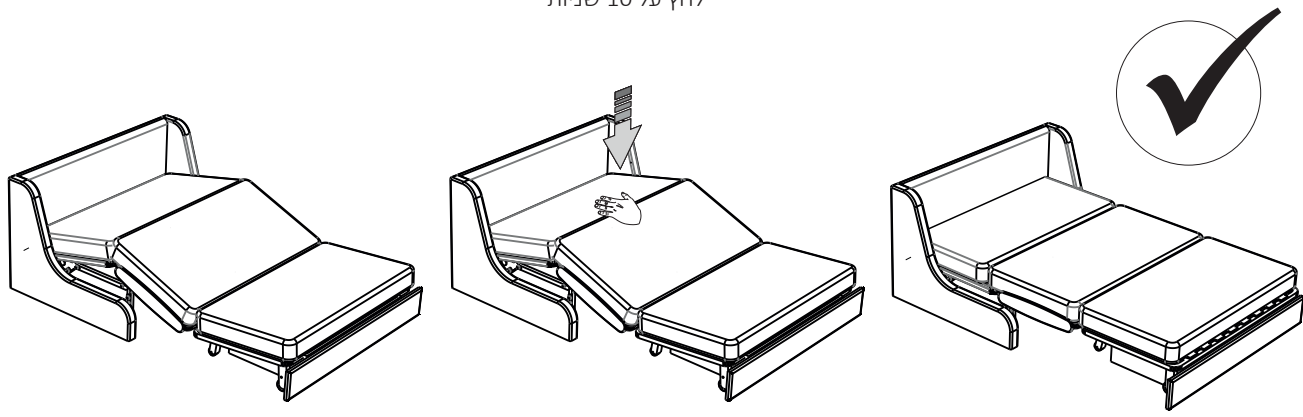

אל תשב בראש המיטה

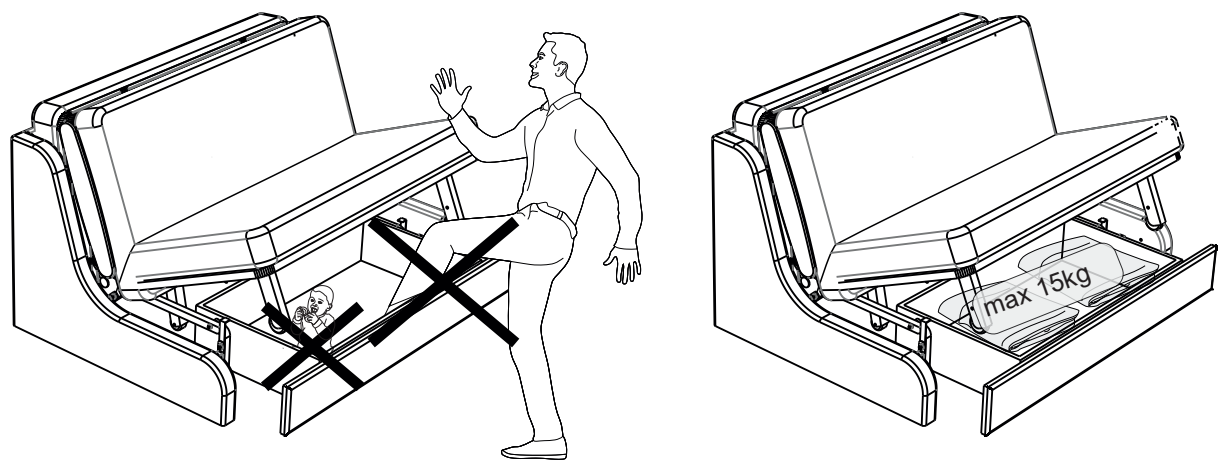





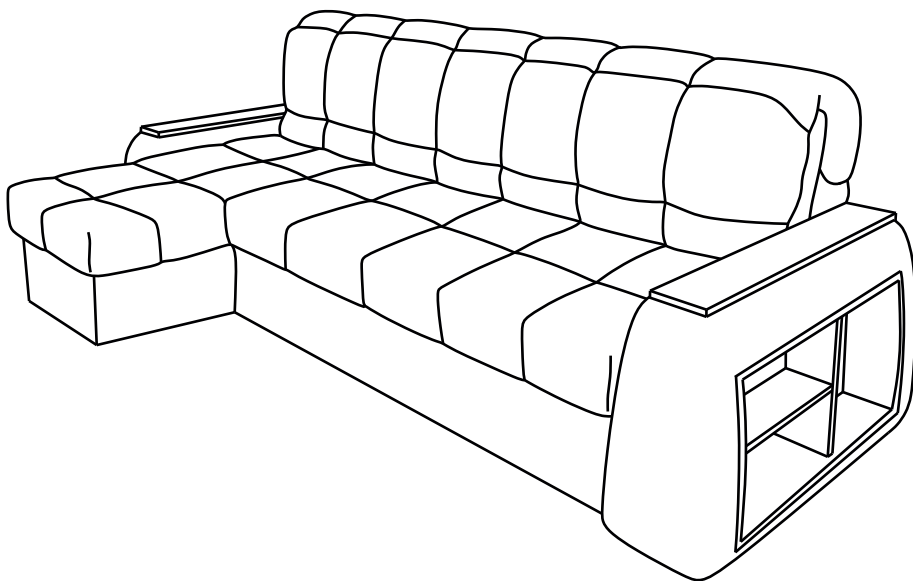
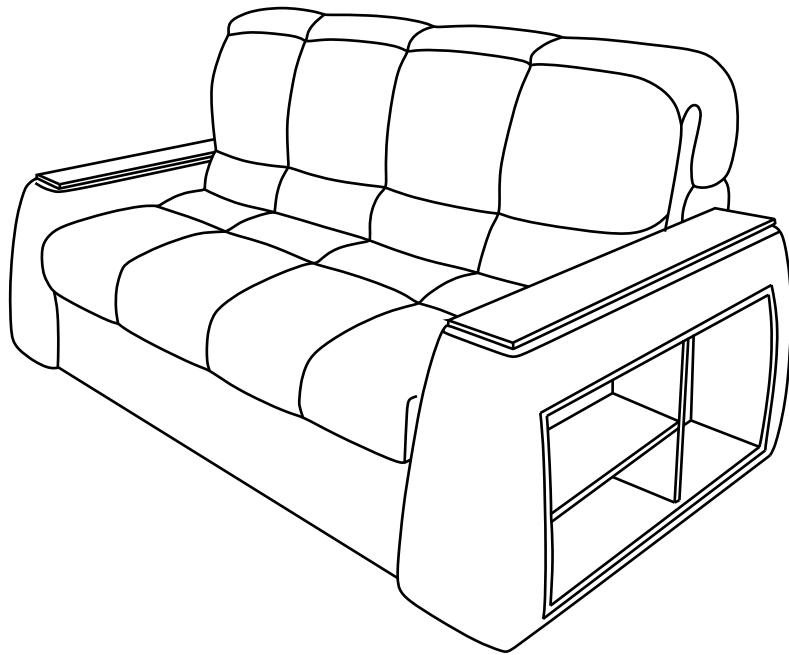

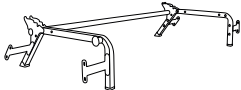

# SUNSET NOVA

DE



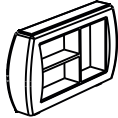
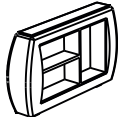

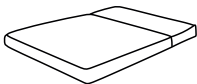
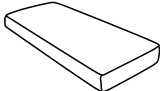

Sleep.8



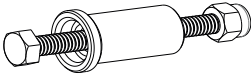

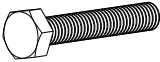
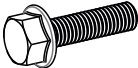
### Lieferumfang des Sofa-Moduls

Verpackung	Sofa-/Sessel-Bett-Modul	Bestellnummer	Name	Betrag
N° 1		D01	Transformations-mechanismus	1
		D26	Unterstützung des Transformations-mechanismus	1
		D04	Lehne	1
		D05	Zarge	1
		D07	Gesteppter Sofa-/Sessel-Bettbezug, Bezugsstoffmuster	1
			Beschlagpaket	1
			Sofapass, Montageanleitung, Stoffmuster	1
N° 2		D06	Armlehne	1
N° 3		D06	Armlehne	
N° 4 Zusätzliche Option		D14	Canape	1
		D11	Canape cushion	1
		D08	Gesteppter Sofa-/Sessel-Bettbezug, Bezugsstoffmuster	1
			Beschlagpaket	1
			Sofapass, Montageanleitung, Stoffmuster	1
Separat erhältlich		D20	Matratze	1
		D21	Canape Matratze	1

### Sofa

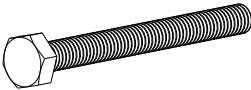
Package	Figure	Part marking	Name	Quantity
Beschlagpaket		DF02 DF15 DF16	BolzenM6x65 Buchse aus Kunststoff Mutter (selbstklemmend)	2
		DF11	SenkkopfschraubM6x30	3
		DF31	Feder mit Haken	2
		DF06	Bolzen M8x45	4
		DF56	Bolzen M8x30	8
		DF42	Unterlegscheibe M8	4

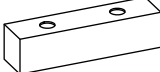
### Canape



Package	Figure	Part marking	Name	Quantity
Beschlagpaket		DF30	Canape Frühling	2
		DF09	Bolzen M8x80	10
		DF19	Mutter M8	6
		DF42	Unterlegscheibe M8	14
		DF74	Canape Rahmenverlängerung	4
		DF75	Mechanismusstopp	2



**Vor der Montage:**

- 1) Überprüfen Sie Art und Unversehrtheit der Teile in der Packung!** Reklamationen werden nur bei Produkten OHNE Montagespuren akzeptiert.
- 2) Bewahren Sie Verpackung bis zum Ende der Montage auf!** Bei Feststellung von Mängeln oder Fehlmengen während der Montage ist die Verpackung bis zum Eintreffen eines Händlervertreters aufzubewahren.
- 3) Überprüfen Sie die Anzahl der Beschlagteile anhand der Liste.** Der Hersteller behält sich vor, konstruktive Änderungen am Produkt vorzunehmen, Beschläge und Befestigungen durch vergleichbare Teile zu ersetzen, die das Aussehen nicht verschlechtern und keinen Einfluss auf die funktionalen Eigenschaften des Produkts haben.
- 4) Halten Sie die Reihenfolge der Montage ein, die in dieser Anleitung angegeben ist!** Bei Nichteinhalten der Montage- und Gebrauchsanleitung erlöschen die Garantieverpflichtungen des Herstellers.
- 5) Wählen Sie für die Aufstellung des Sofas eine ebene Bodenfläche!** Bei Bodenunebenheiten sind Abweichungen von der Funktion des Verwandlungsmechanismus des Sofas und Verwindungen der Form des Produktes möglich.
- 6) Führen Sie den Zusammenbau des Sofas zu zweit durch.** Bewegen Sie alle Teile sorgsam, ohne ruckartige Bewegungen, lagern Sie die Teile sicher, vermeiden Sie Fall- und Schlägeinwirkung.
- 7) Bewegen Sie das Möbelstück und seine Teile nur in leicht angehobenem Zustand.** Dies hilft, Deformation und Bruch zu vermeiden.
- 8) Schmieren Sie den Verwandlungsmechanismus bei der Montage unbedingt entsprechend der Anleitung!** Dadurch wird das Auftreten von einem frühzeitigen Knarren des Metallrahmens des Sofas vermieden. Wiederholen Sie den Schmiervorgang mindestens einmal alle sechs Monate.

**Zum Zusammenbau benötigen Sie:**

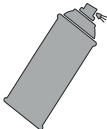
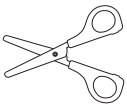
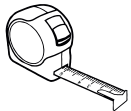
	Kreuzschlitzschraubendreher
	Schraubenschlüssel №13 x 2 Schraubenschlüssel №10 x 1
	Papierhandtuch
	Silikon-Sprühschmiermittel
	Schere
	Roulette

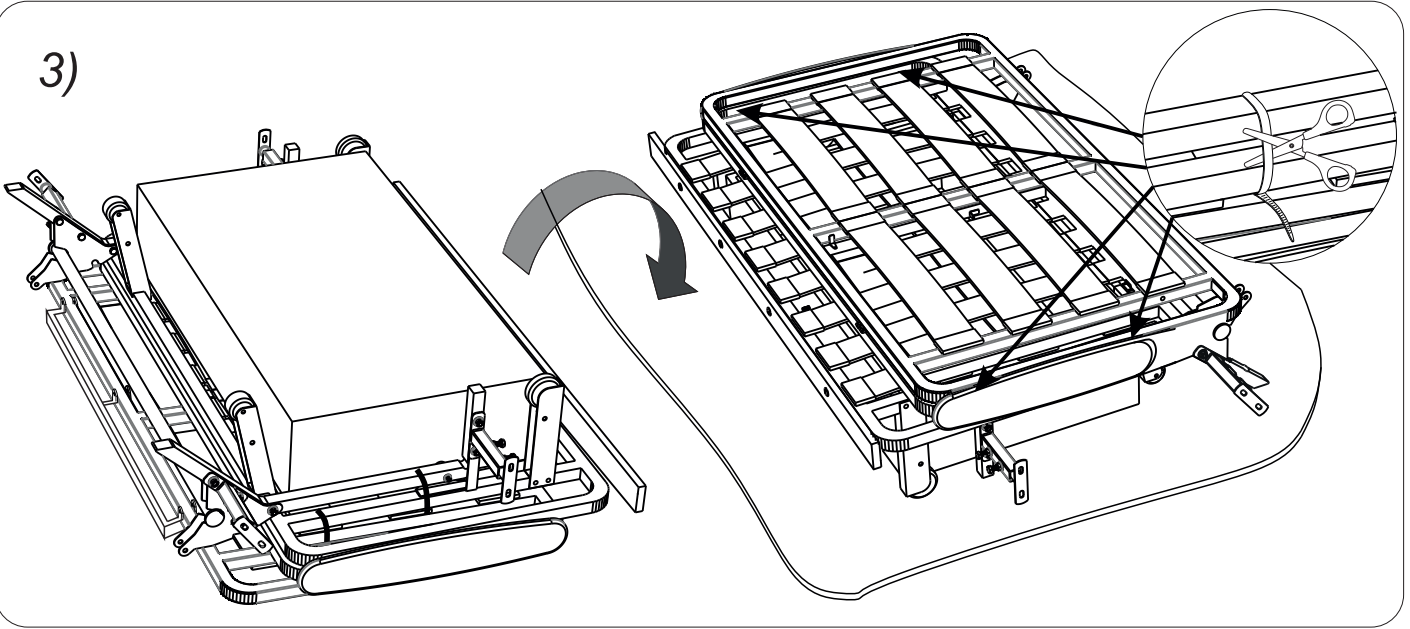
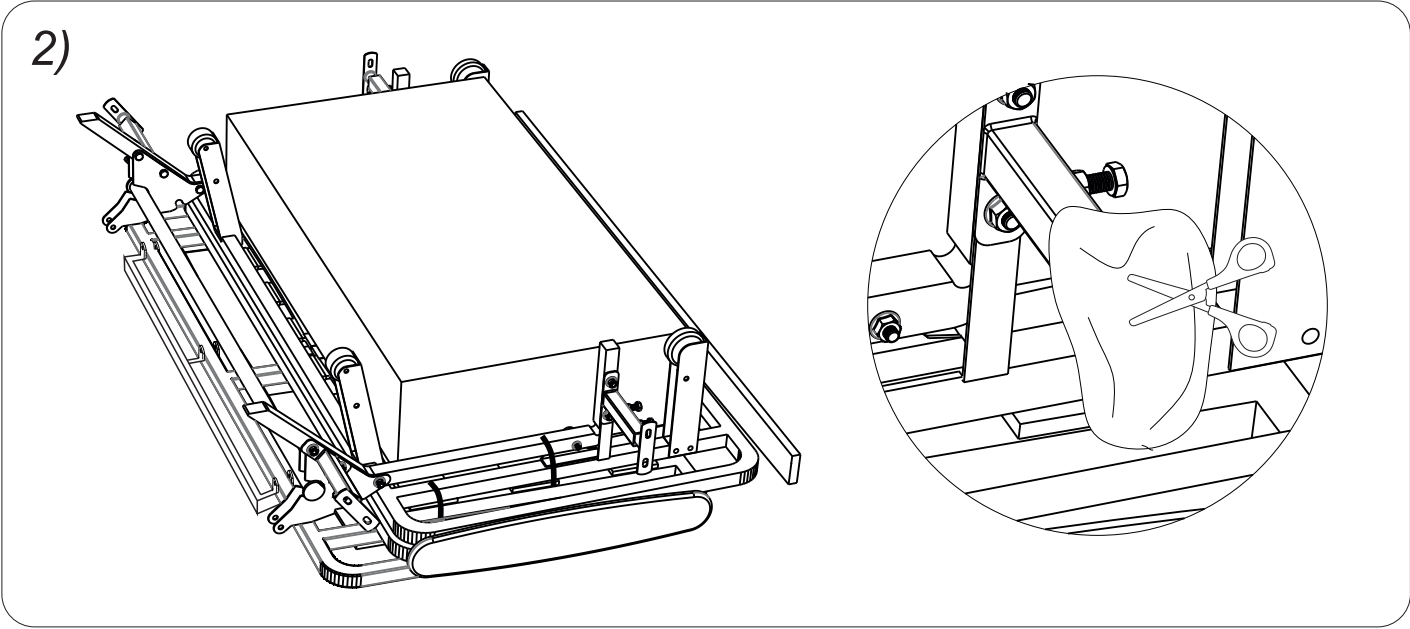
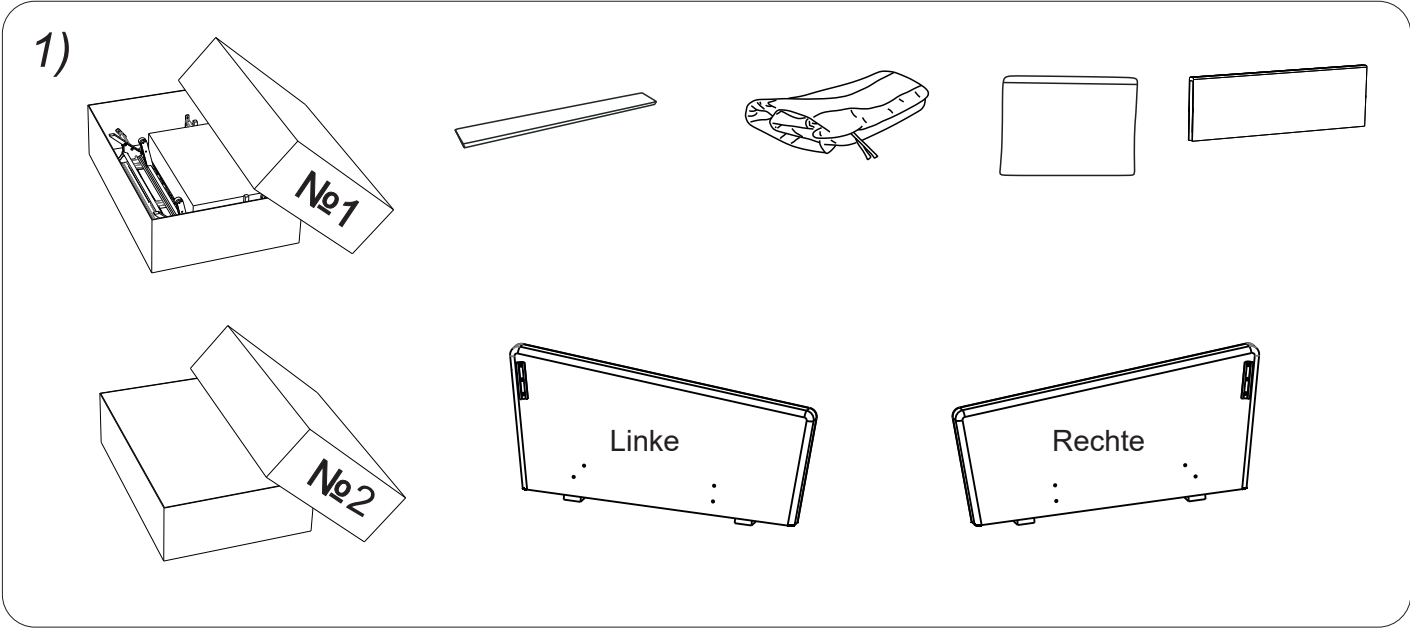

4)

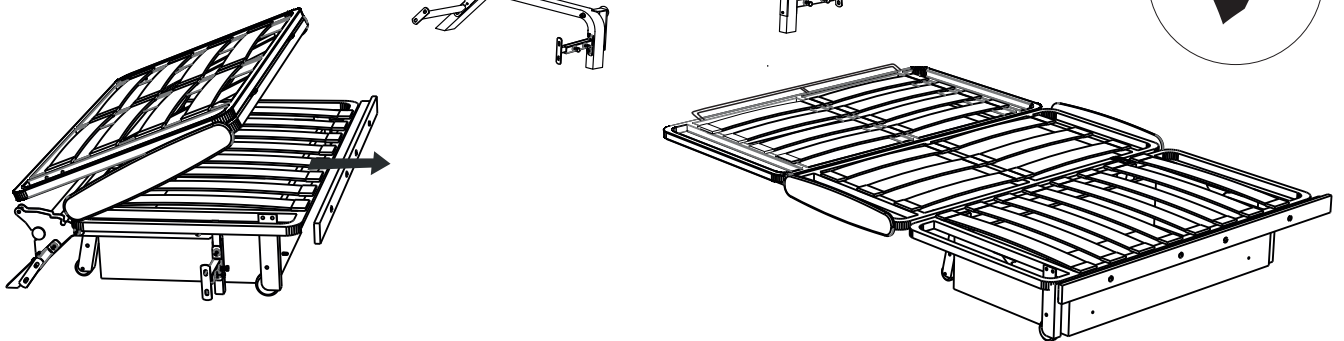

Entfernen Sie den Rahmen von der Basis

5)

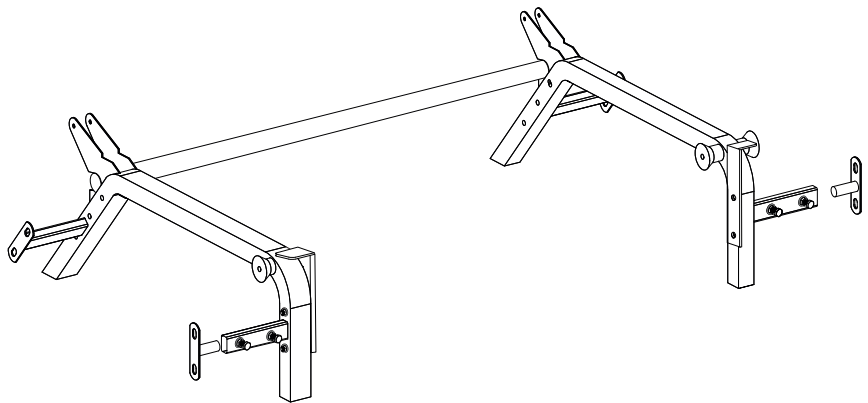
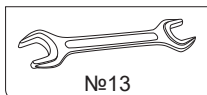
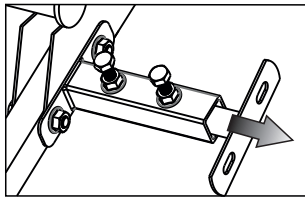
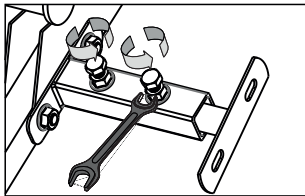

6)

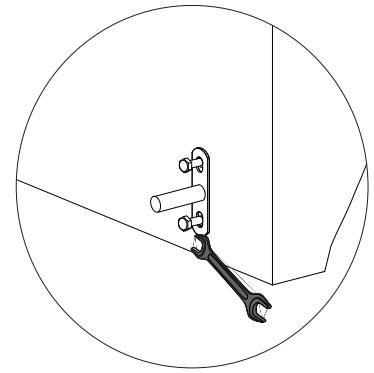
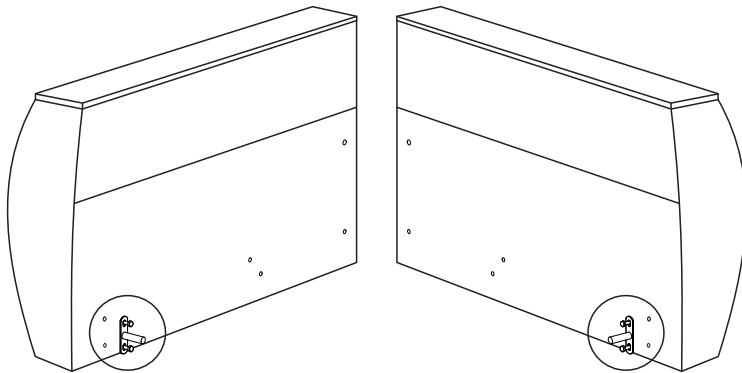

DF56

№13

Wenn Sie ein Ecksofa zusammenbauen, montieren Sie die Halterung an einer Armlehne (von der Seite gegenüber dem Sofa).

7)

Ziehen Sie die Schrauben der Halterung nicht fest

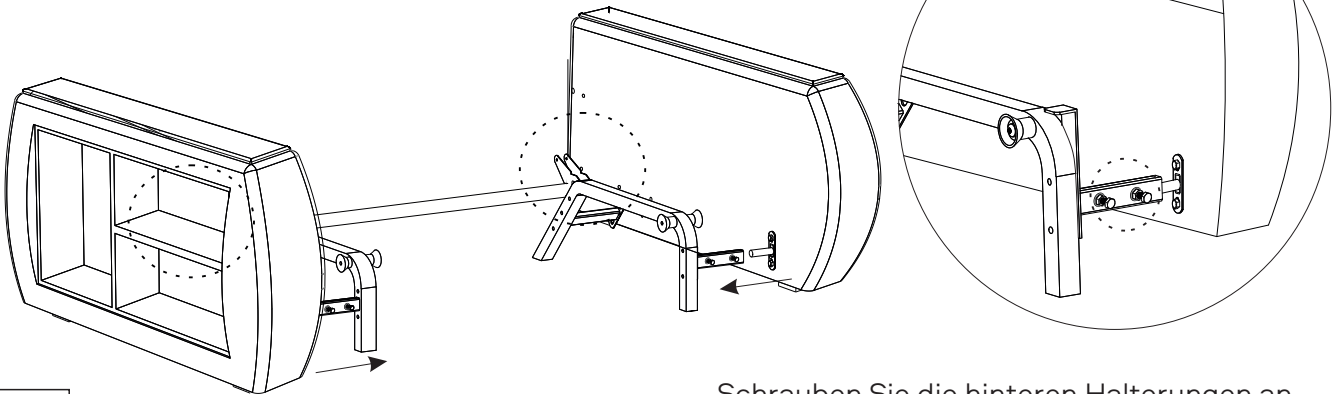

Schrauben Sie die hinteren Halterungen an.  
Ziehen Sie die Schrauben der vorderen  
Halterung nicht fest.

8)

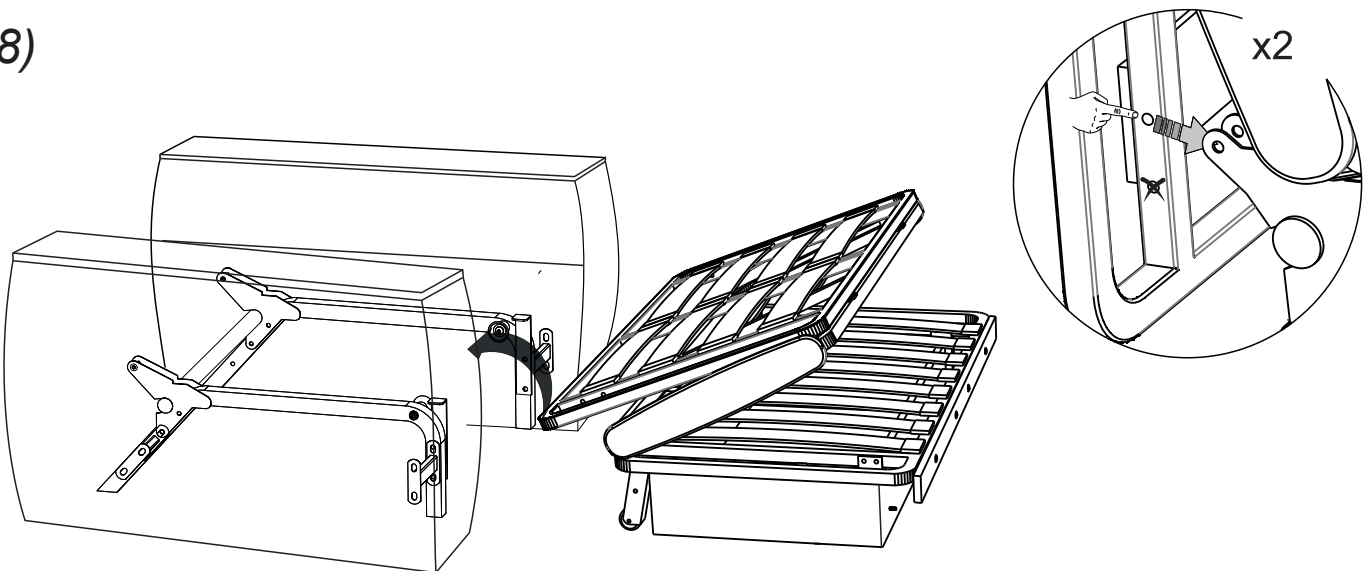

9)

Ziehen Sie es nicht zu fest an

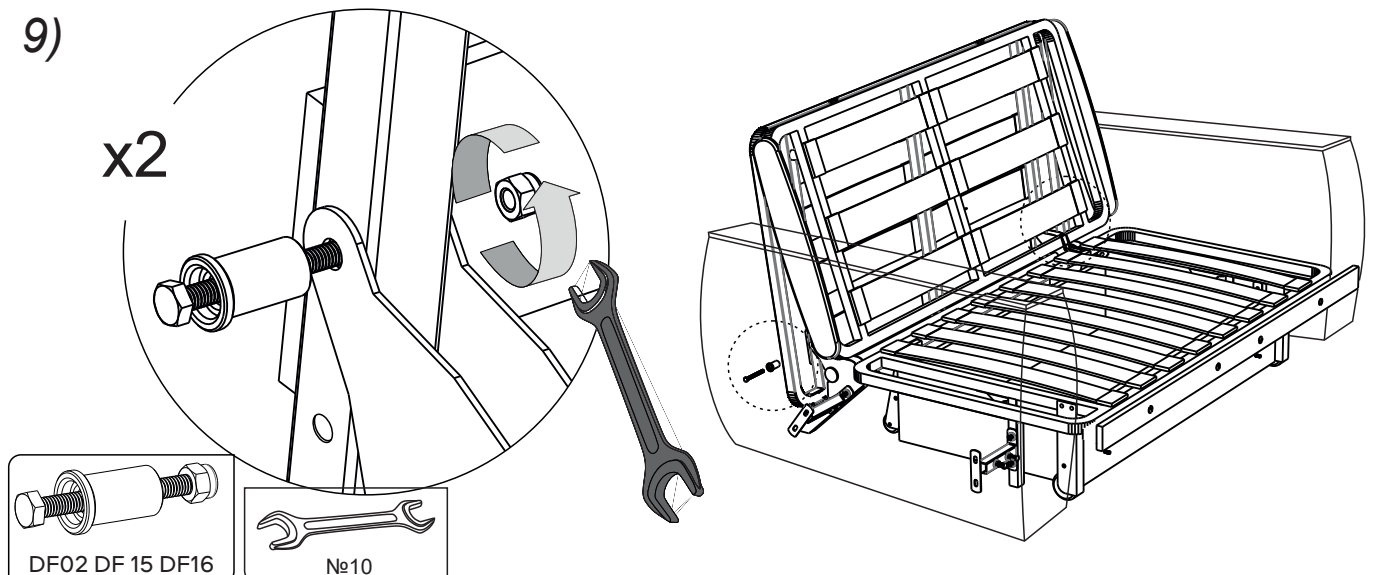

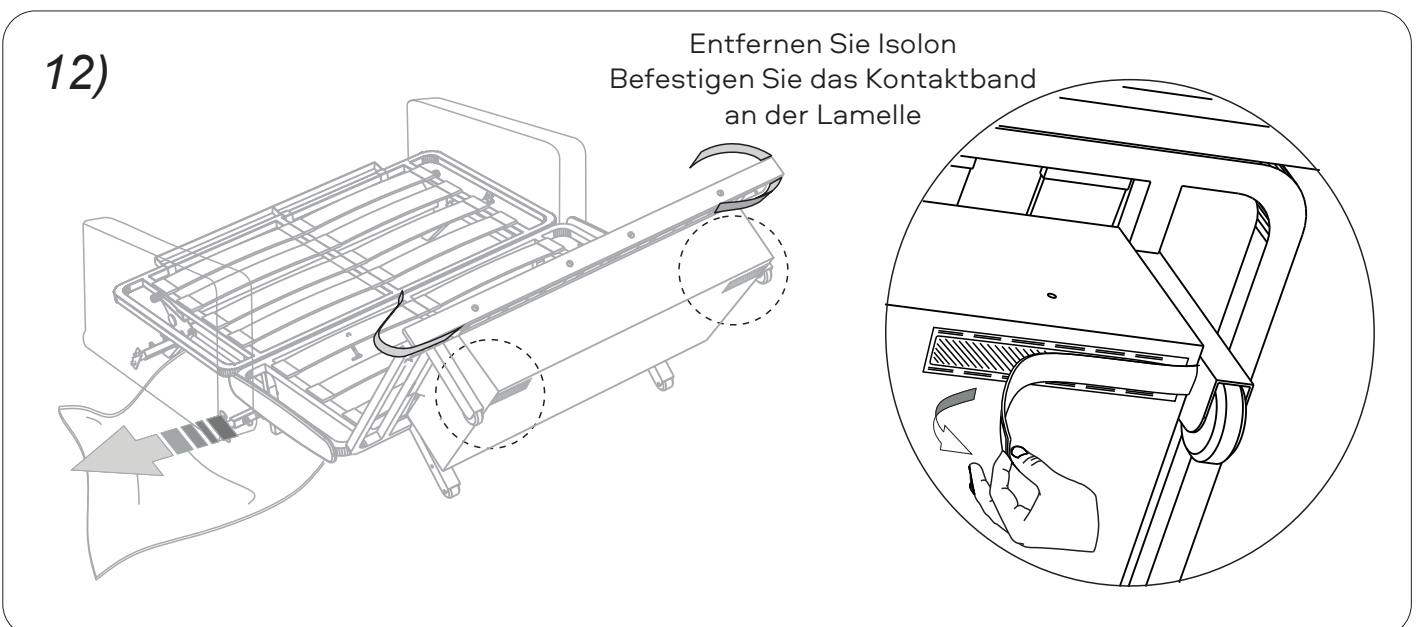
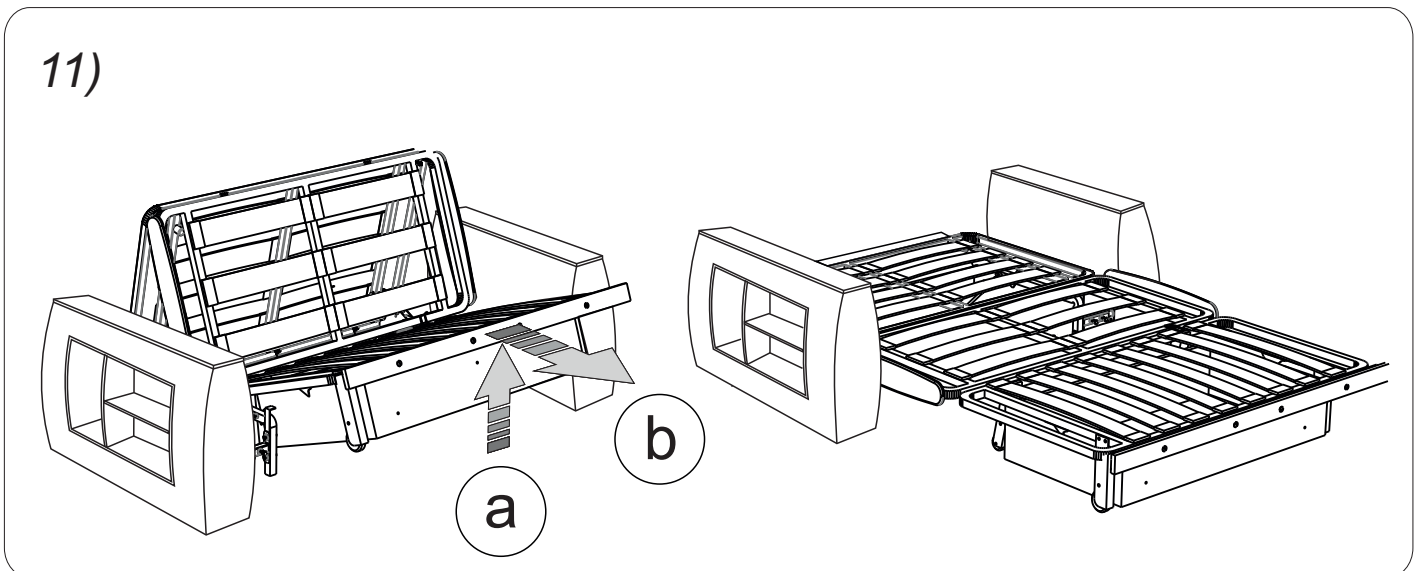
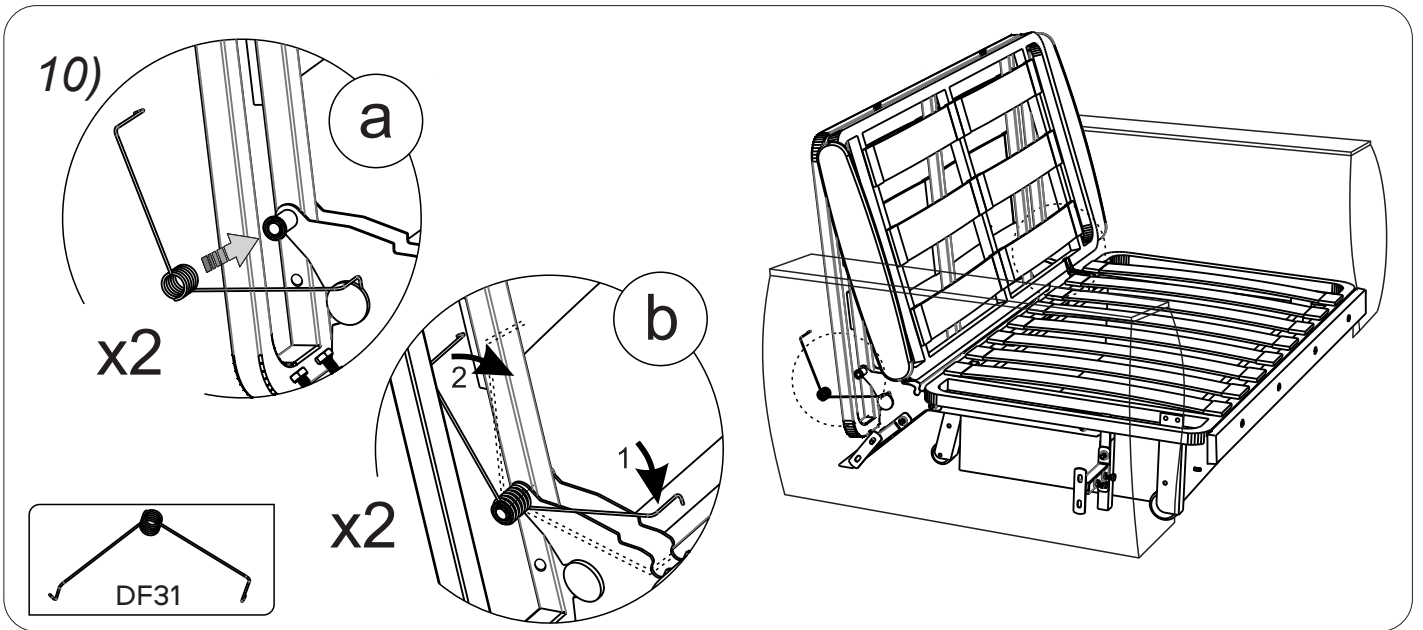

13)

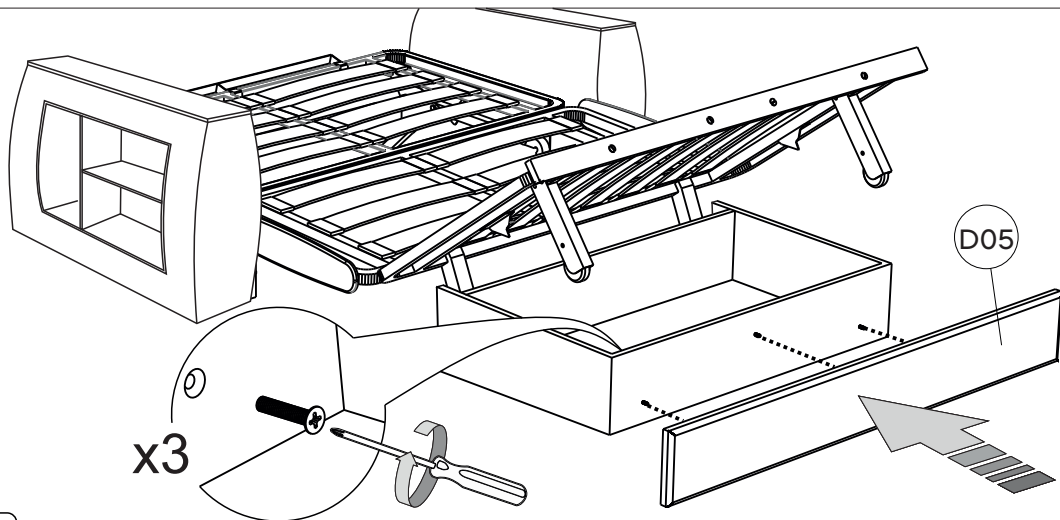

DF11

Der Boden der Zarge wird durch das Vorhandensein einer Halterungsleiste bestimmt.

14)

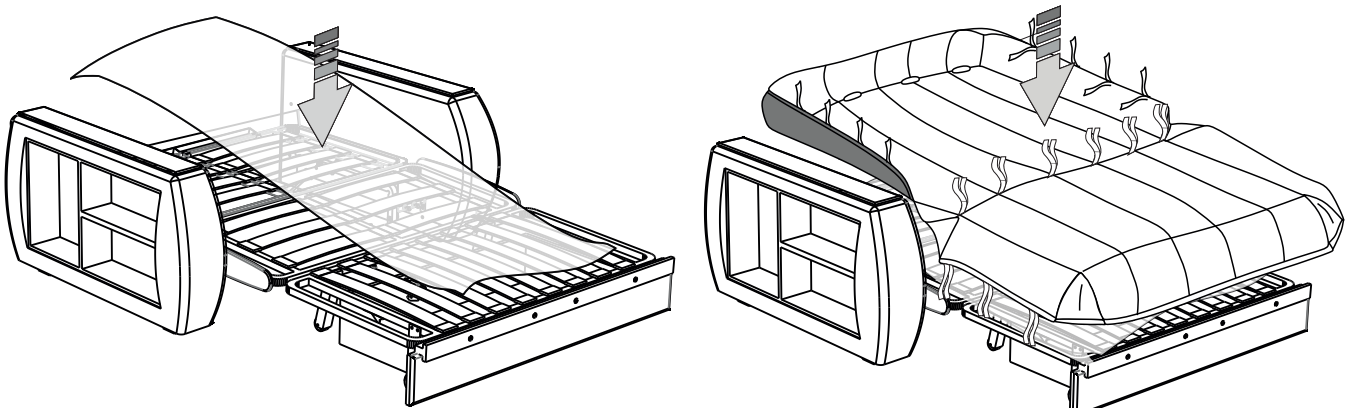

Legen Sie die Folie aus der Sofaverpackung auf die Mechanik, um den Bezug vor Schmutz zu schützen.

15)

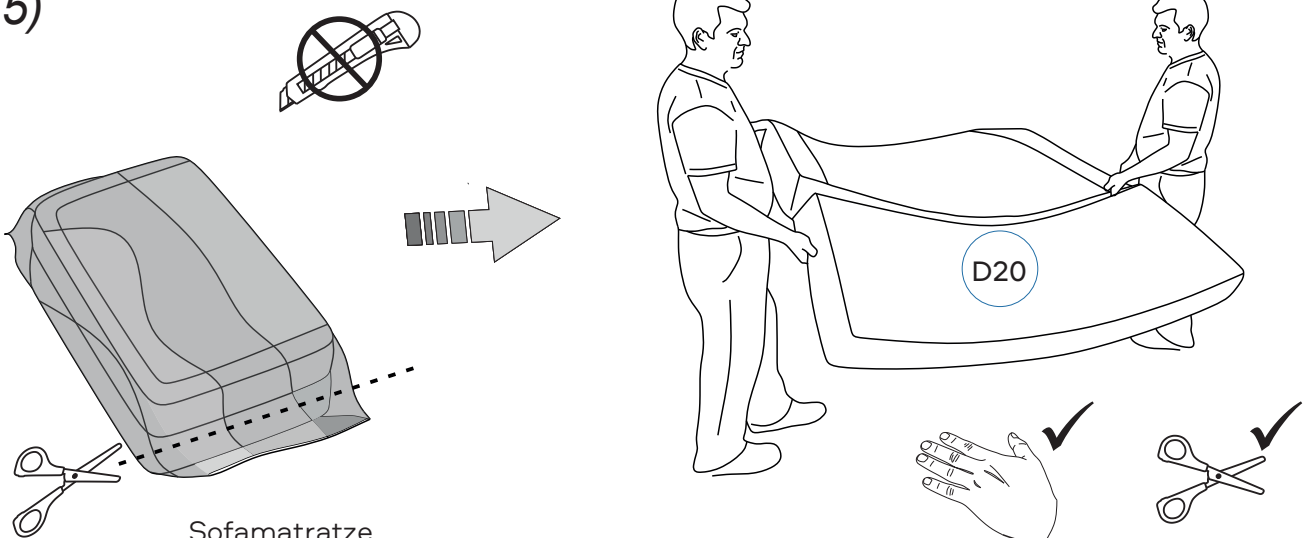

Sofamatratze



16)

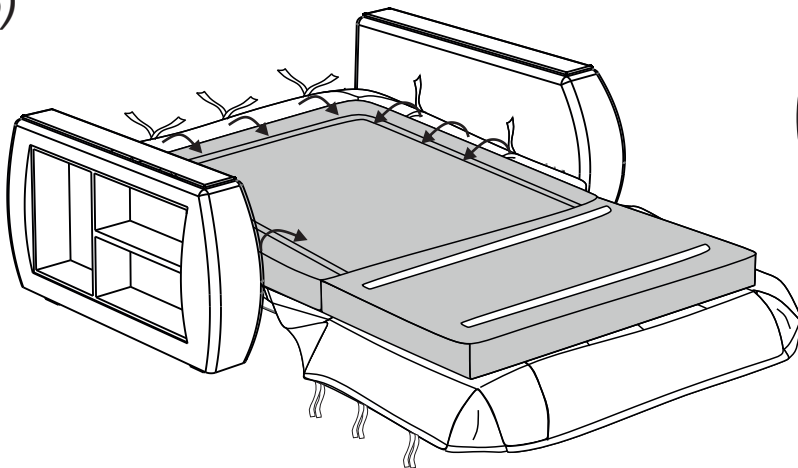

Richten Sie die Nähte und Ecken von Matratze und Bezug aus.  
Fädeln Sie die Kontaktbänder am Kopfende in die Löcher in der Abdeckung ein.

17)

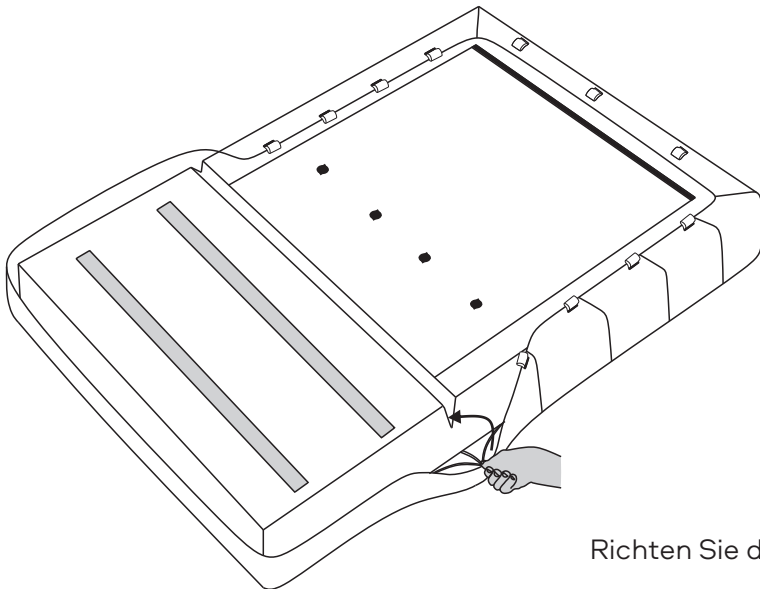

Richten Sie die Naht von Bezug und Matratze aus.

18)

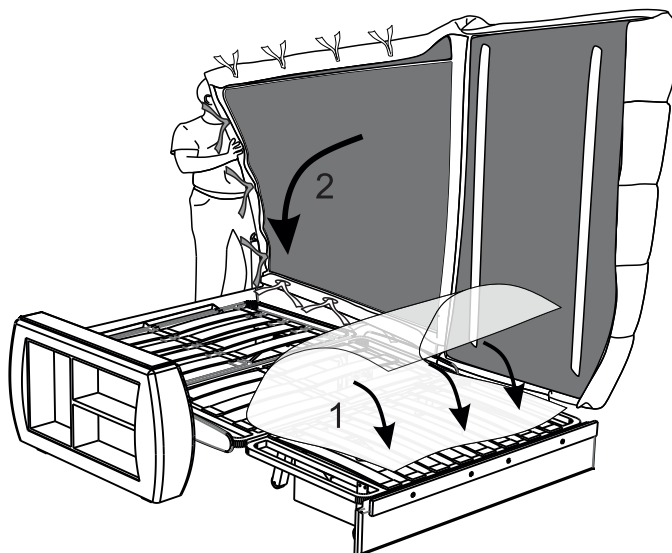



19)

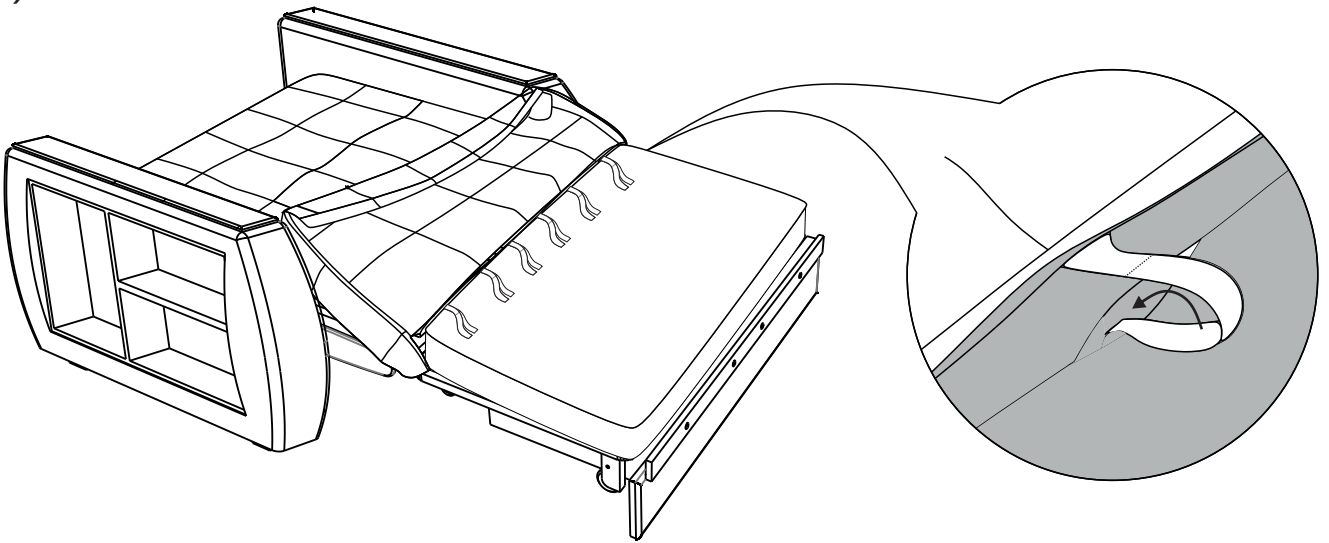

20)

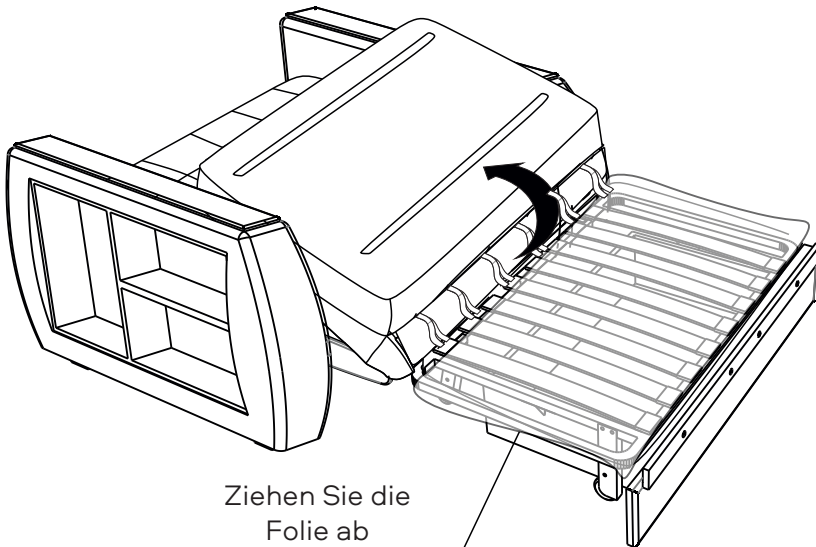

Ziehen Sie die  
Folie ab

21)

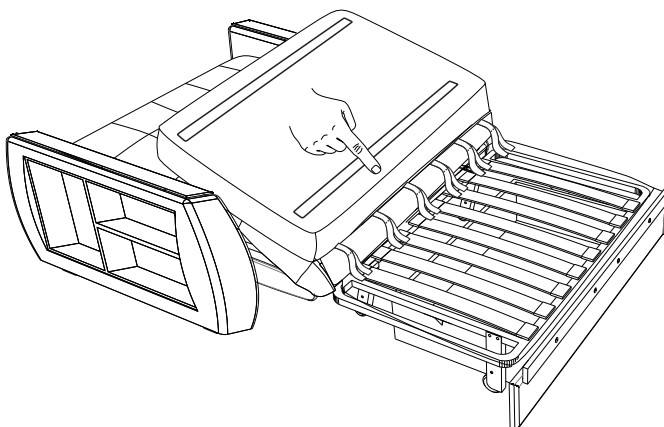

✘

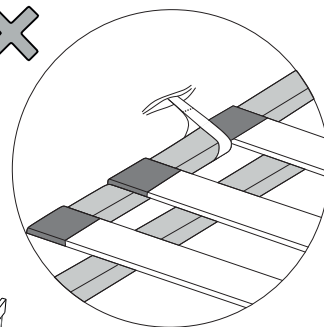

✔

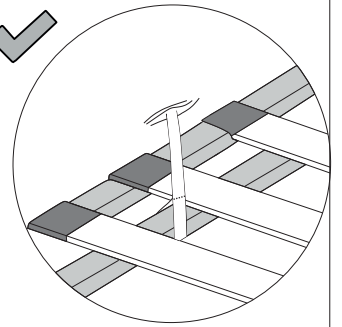

Haken Sie die  
Kontaktbänder ein und  
ziehen  
Sie sie fest an der Nahtlinie  
fest.

22) Die Matratze sollte maximal 1 cm über die Lattenkante hinausragen

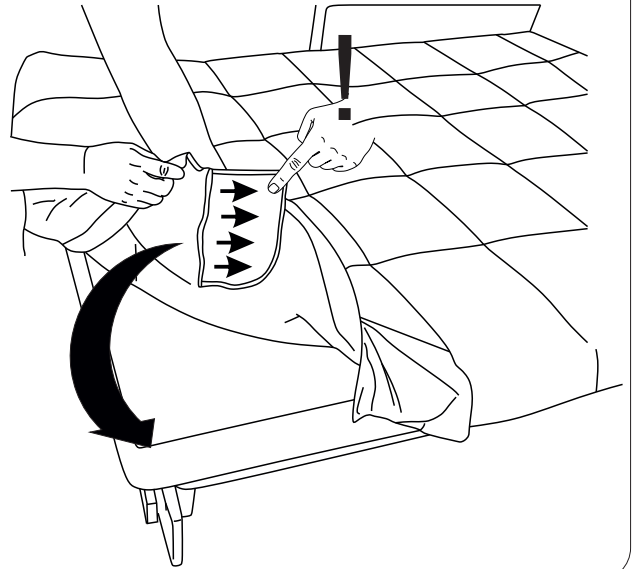
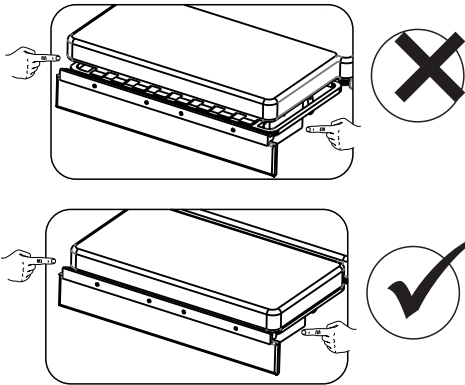

23)

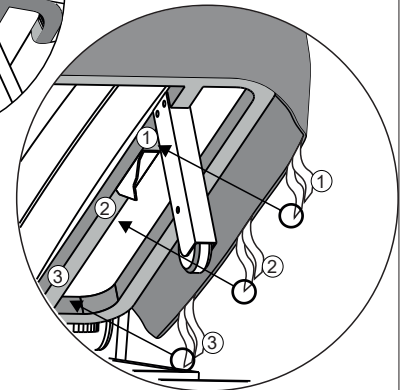
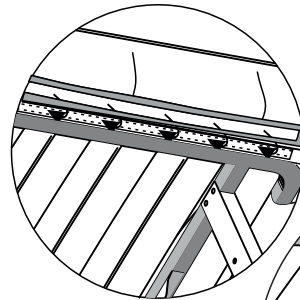
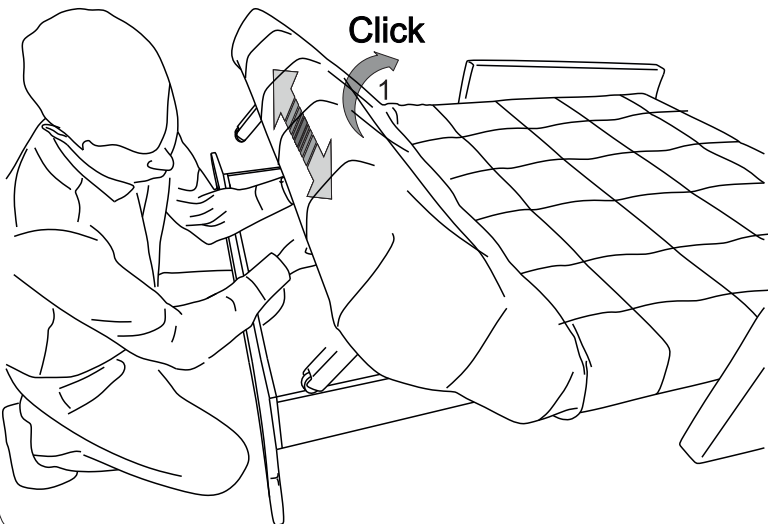

24)

Sammeln Sie überschüssigen Bezug an der Falte der Matratze, um die Umwandlung zu erleichtern

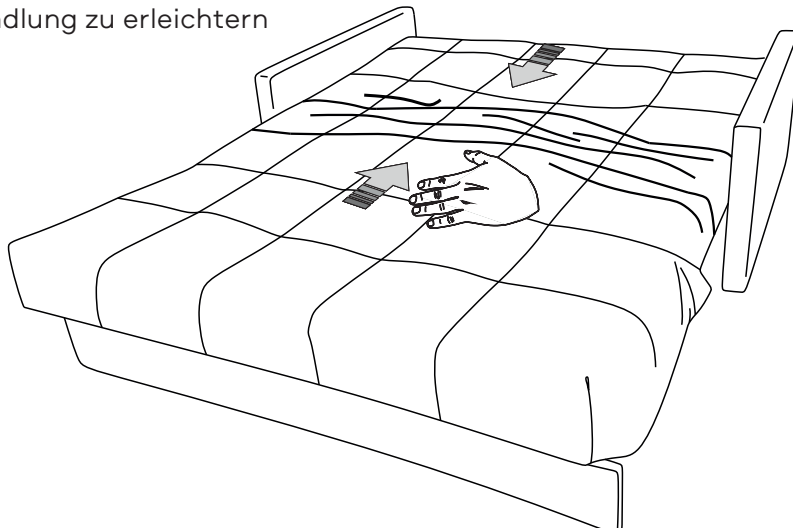

25)

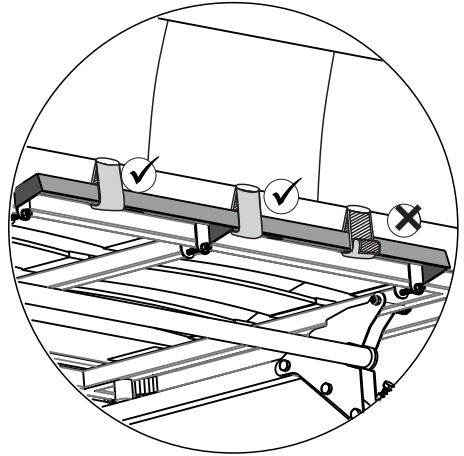
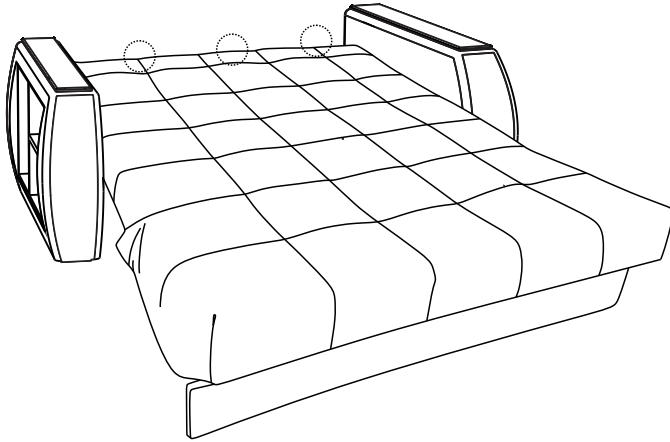

26)

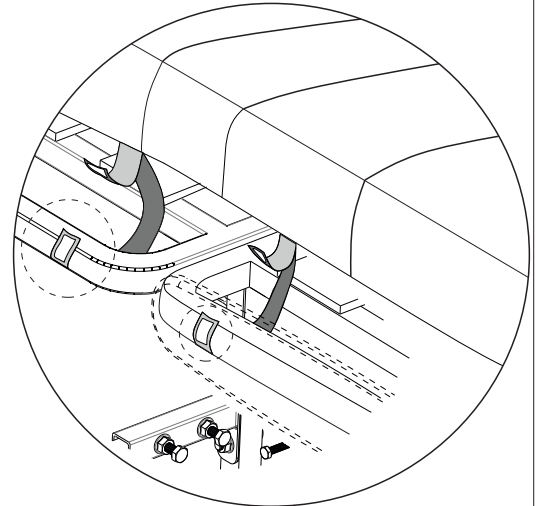
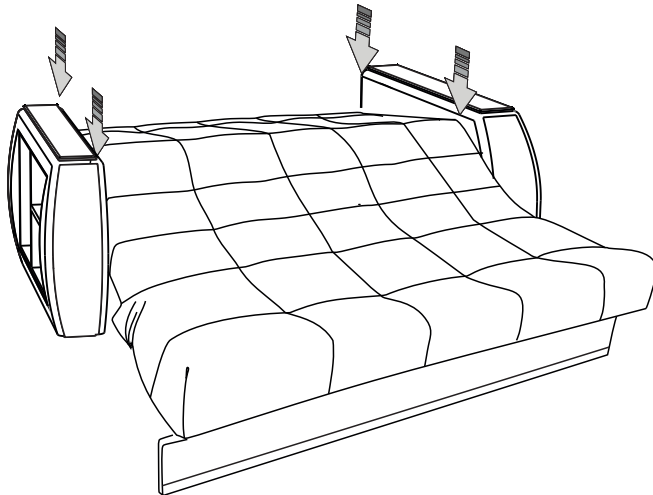

Bewegen Sie das Sofa in eine halb ausgeklappte Position.  
Bei der Befestigung müssen die Kontaktbänder so fest wie möglich angezogen werden.

27)

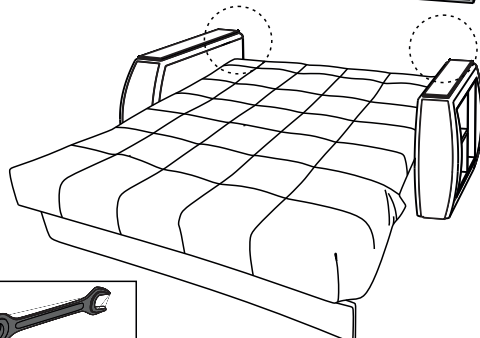
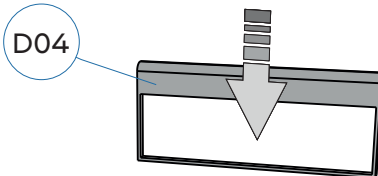

DF42

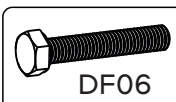

DF06

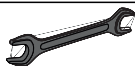

№13

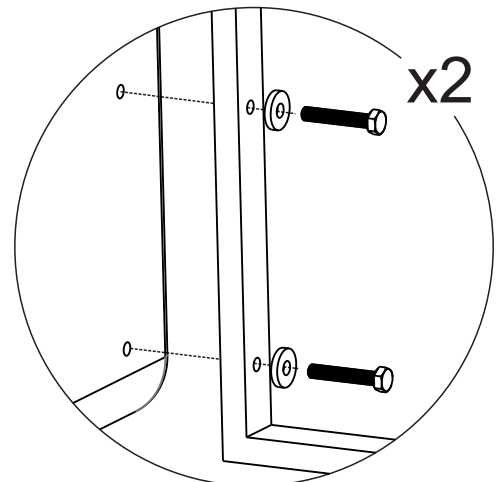

x2

28)

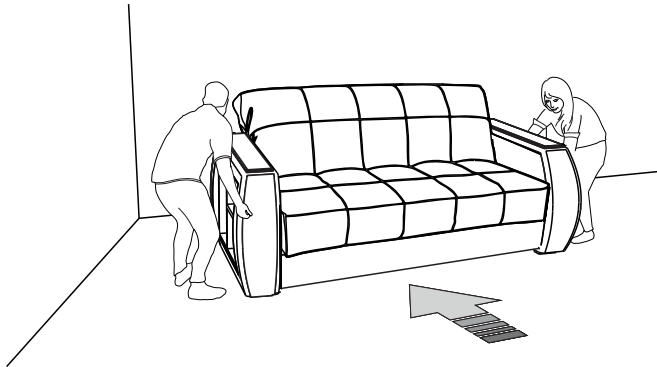

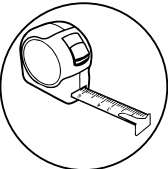
$A \approx B$  <sup>OK</sup> 

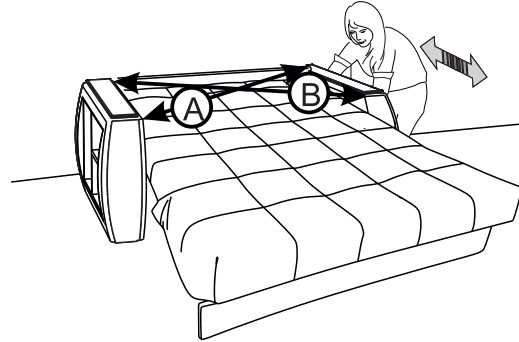

Stellen Sie das Sofa an einem Ort auf, an dem es dauerhaft genutzt wird

29)

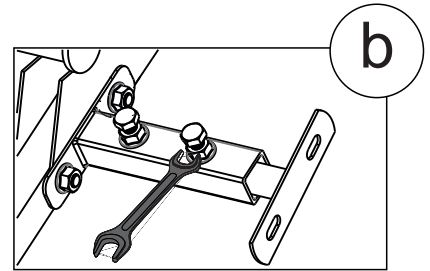
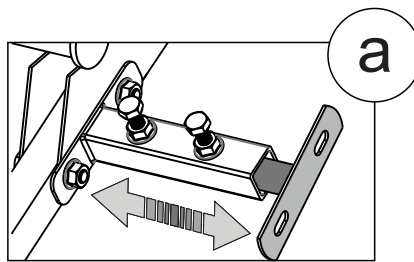
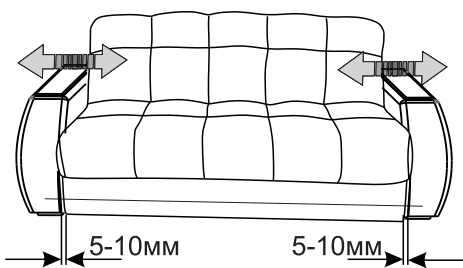

Festziehen!

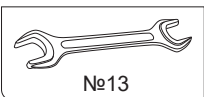

30)

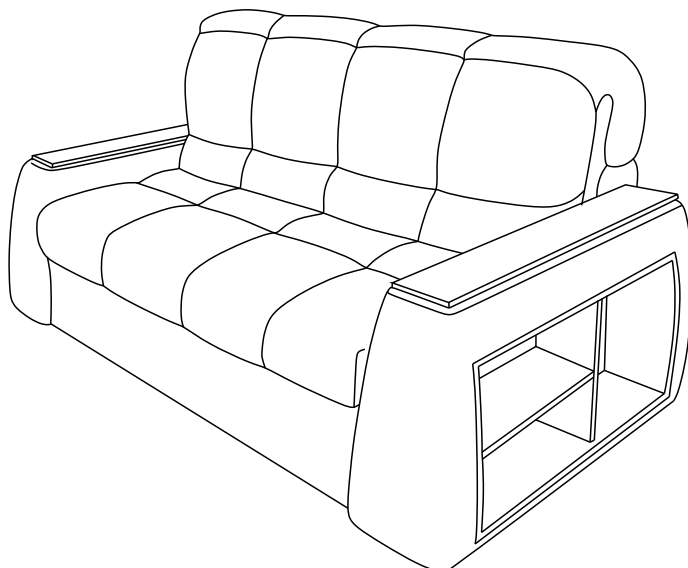

31)

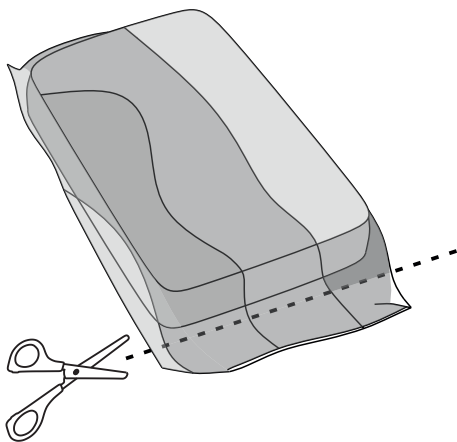
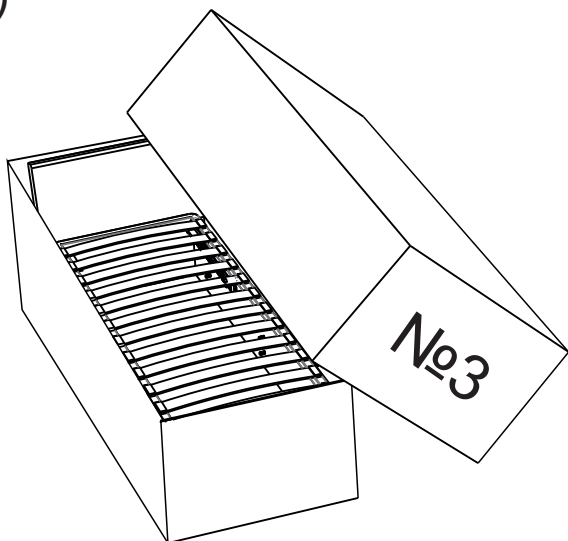

32

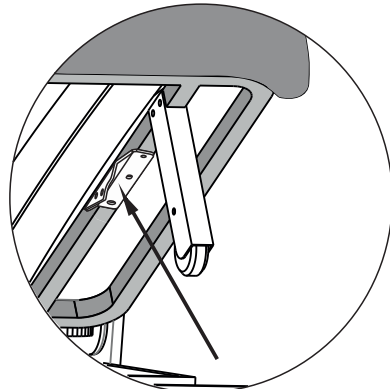
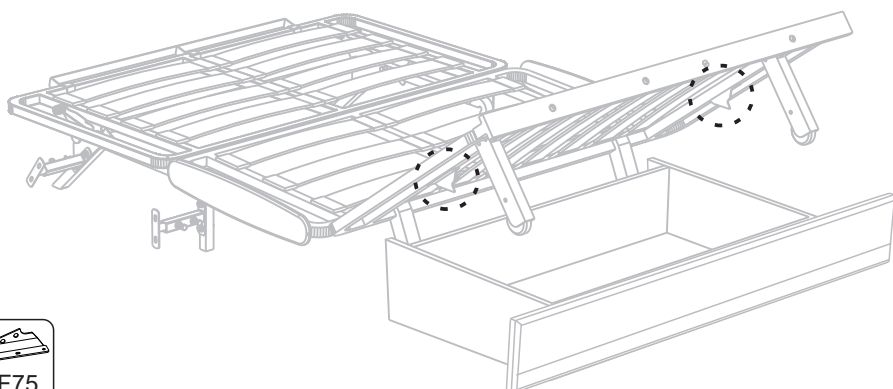

33)

Federn werden nur auf einem kleinen Sofa installiert

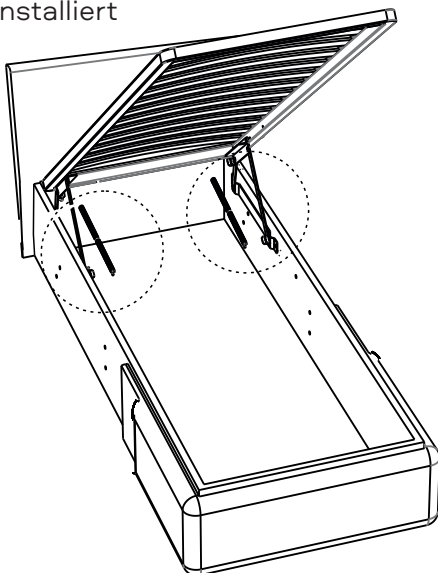
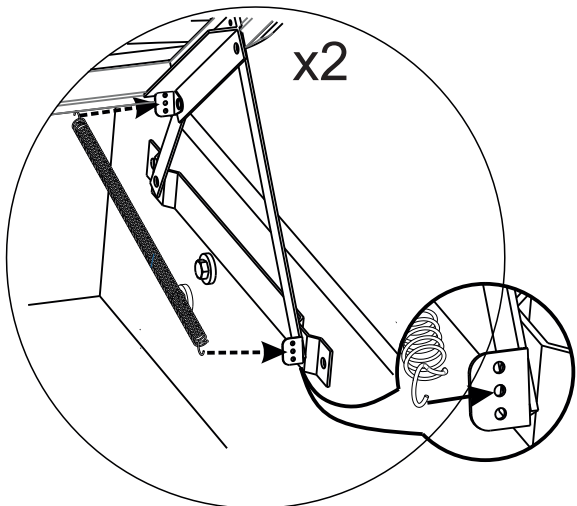

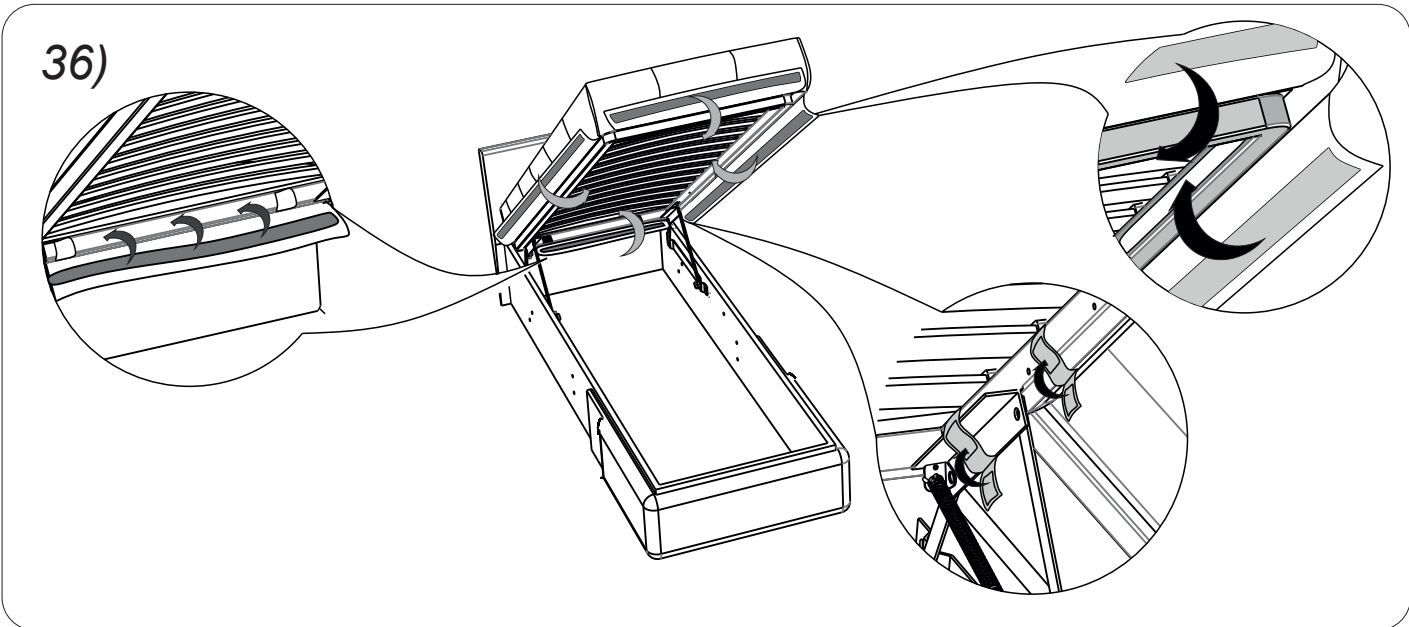
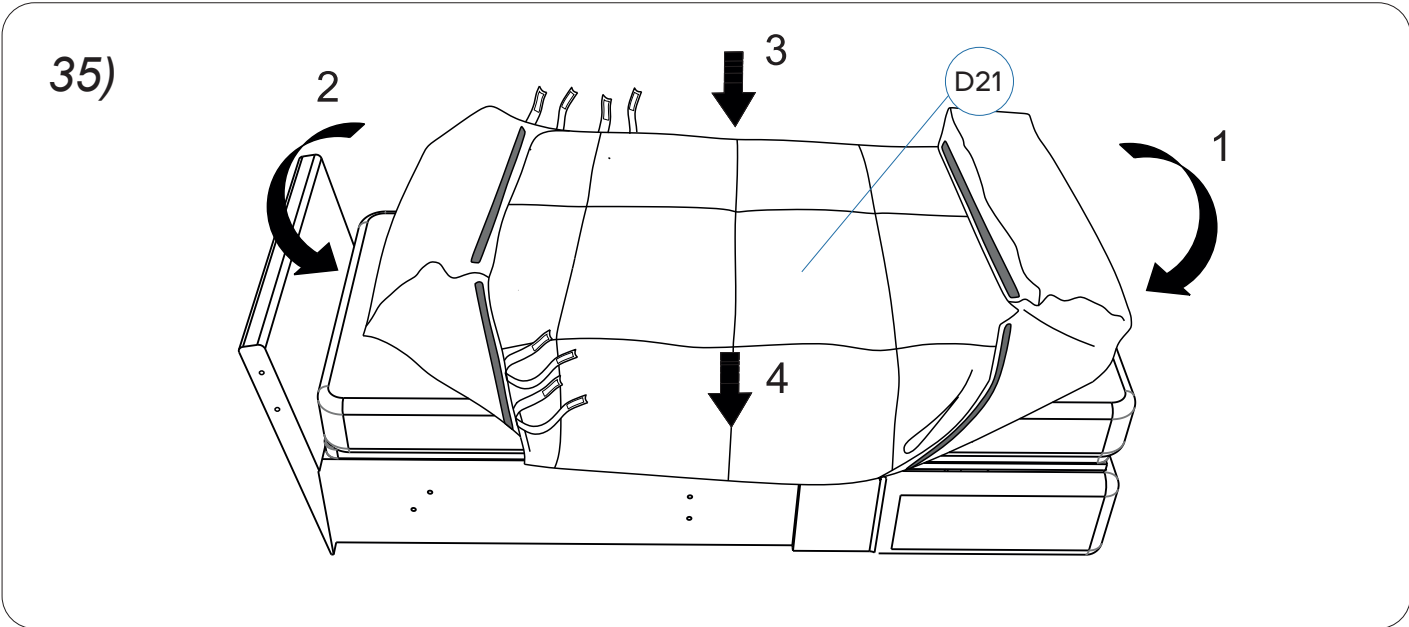
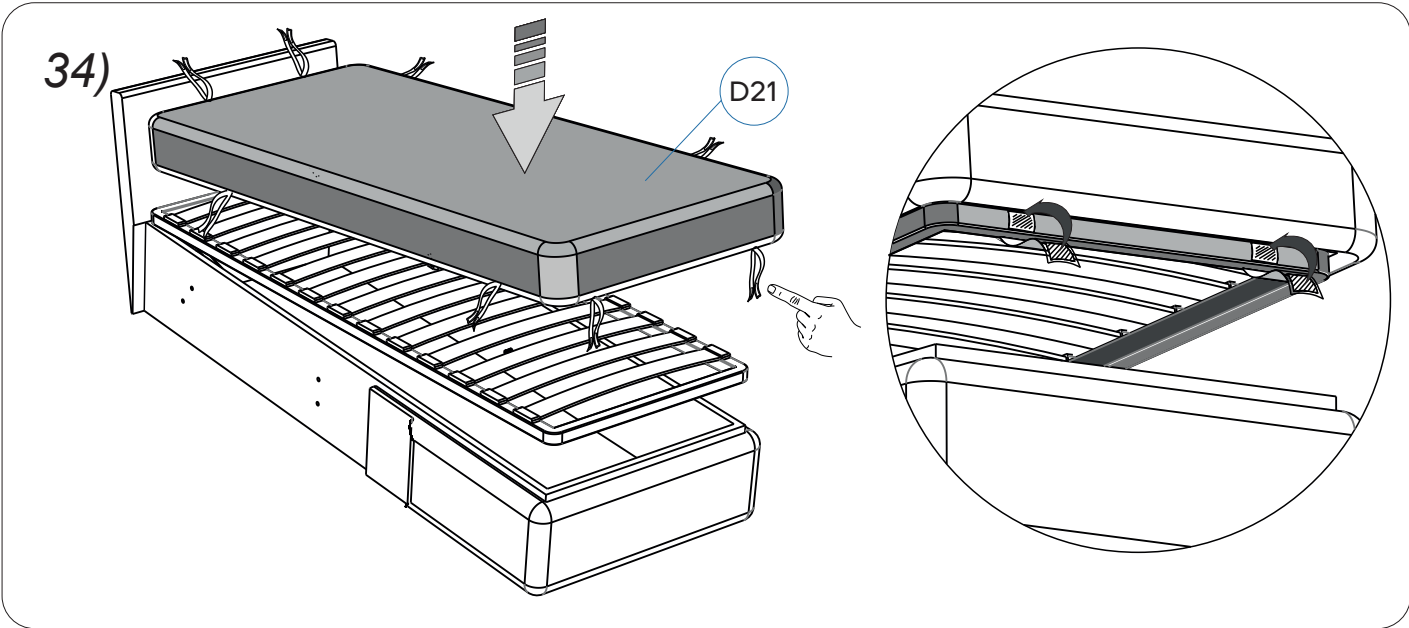



37)

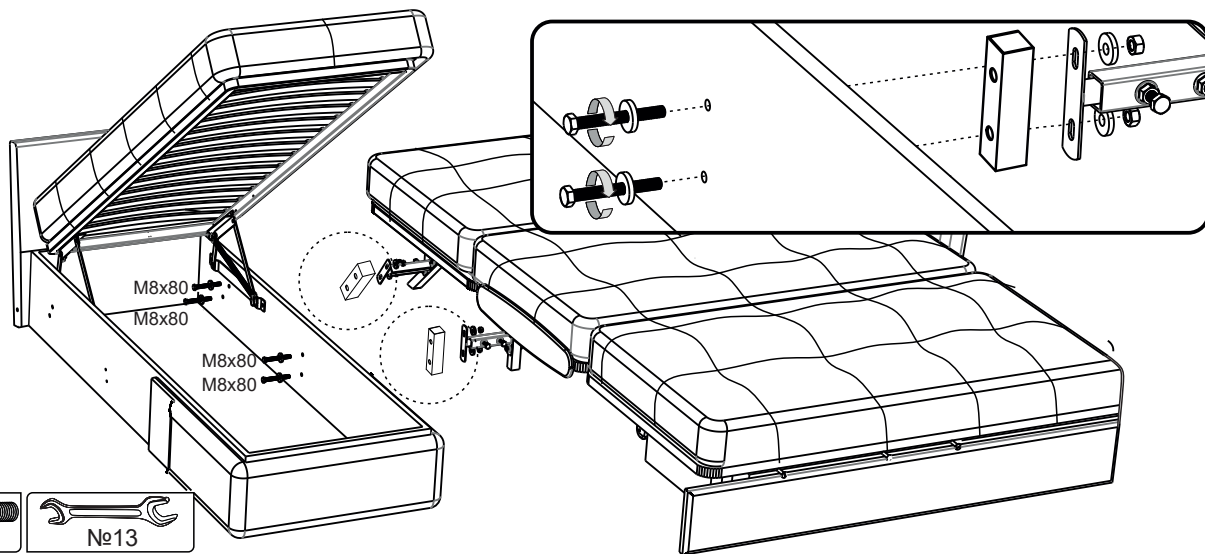

38)

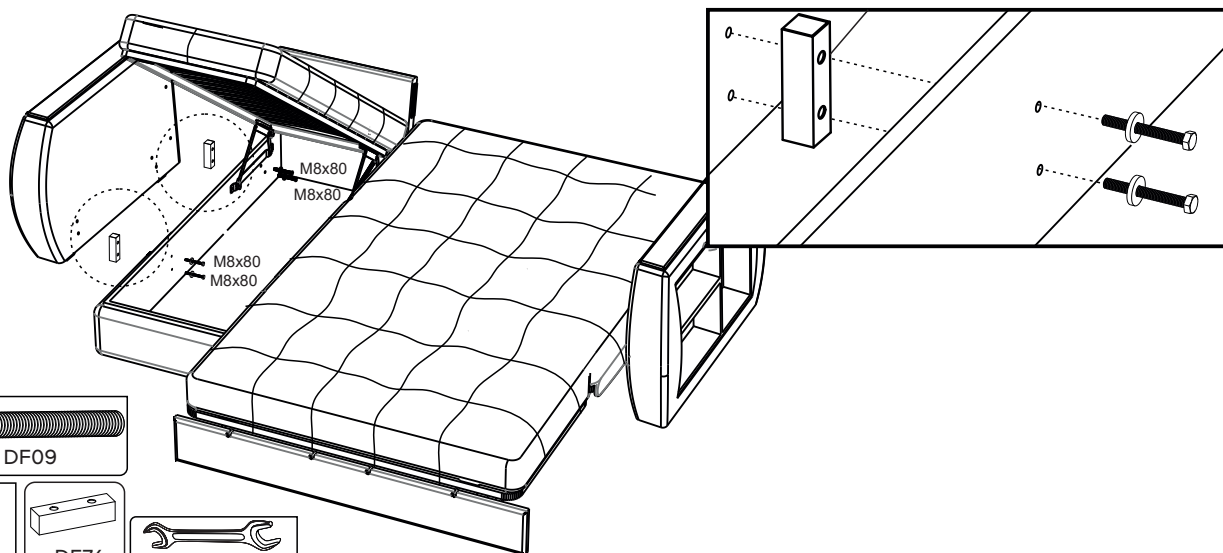

39)

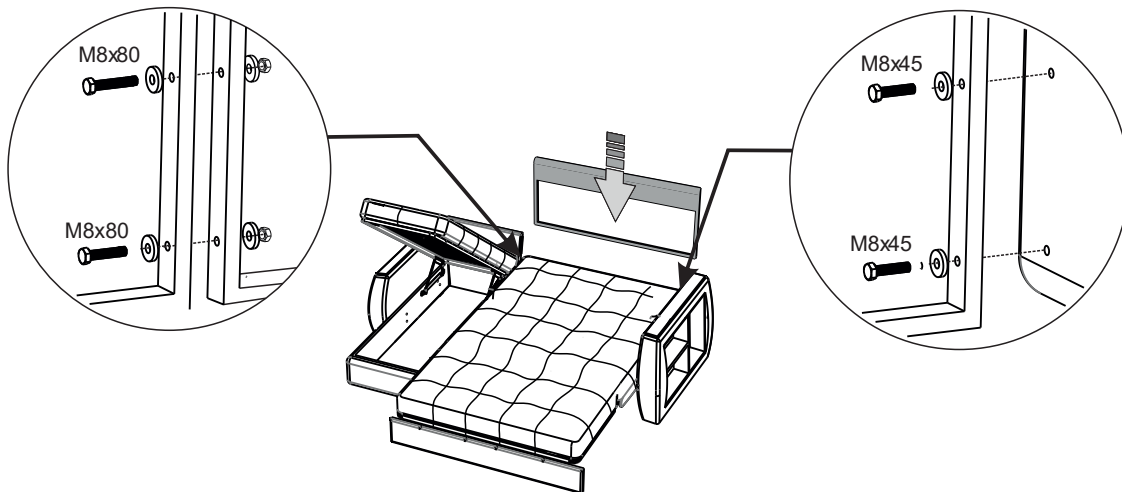



40)

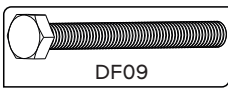
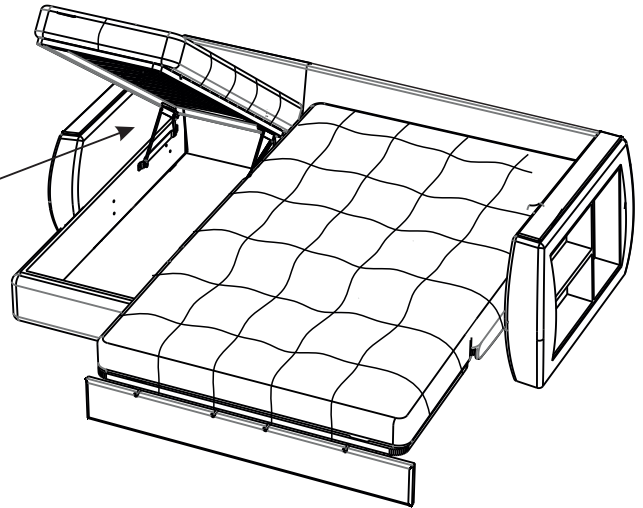
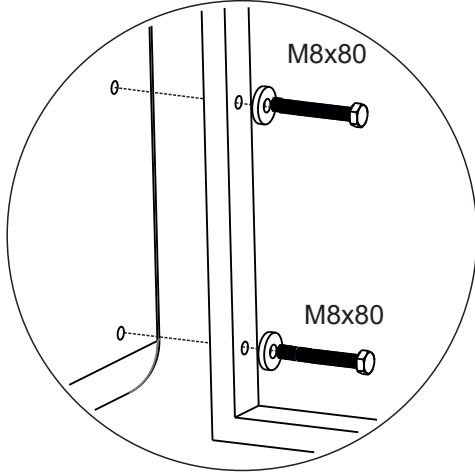

41)

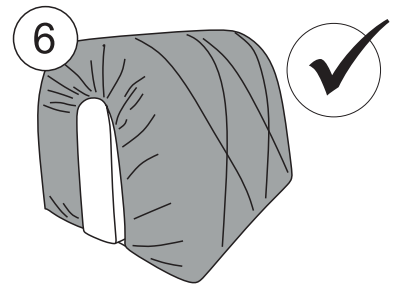
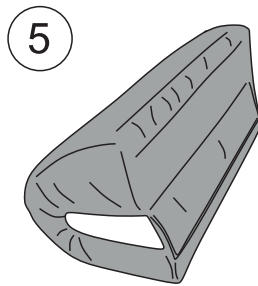
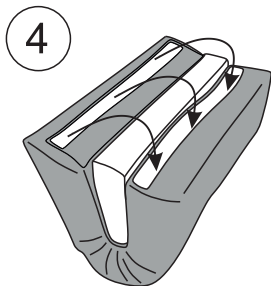
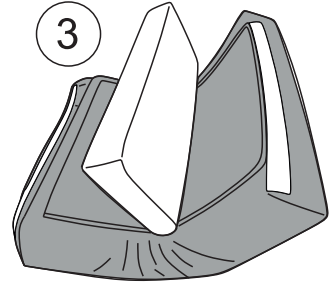
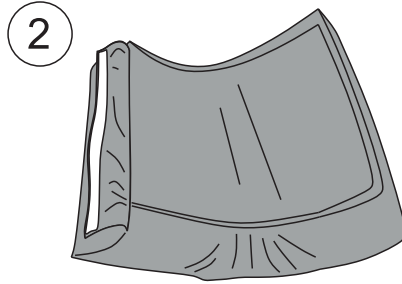
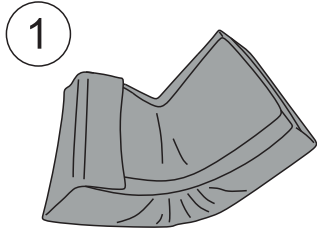

42)

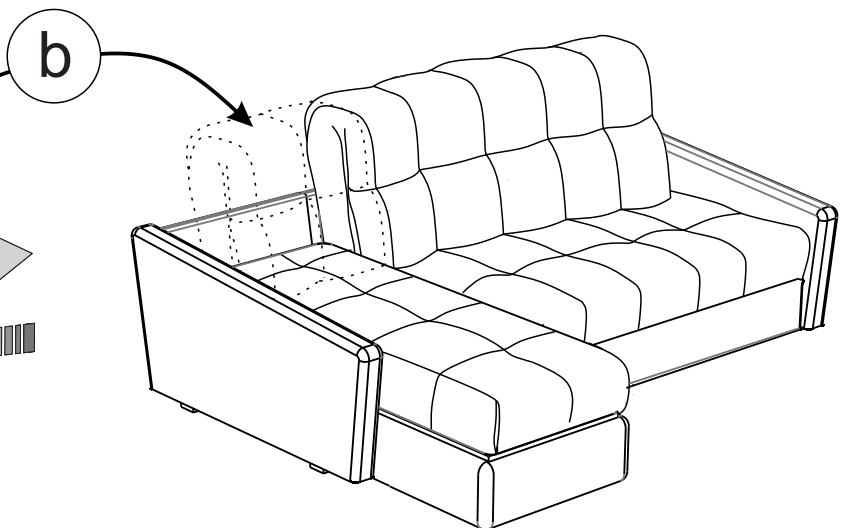
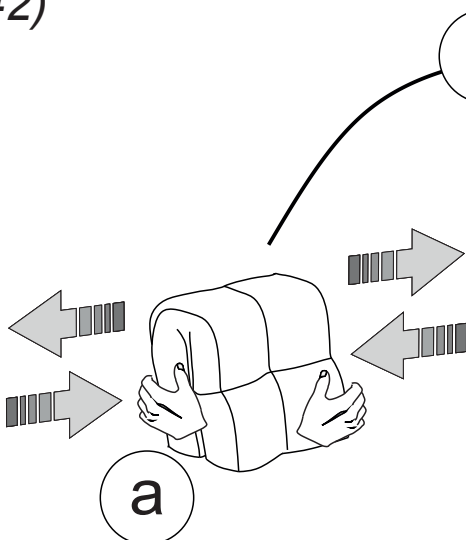

43)

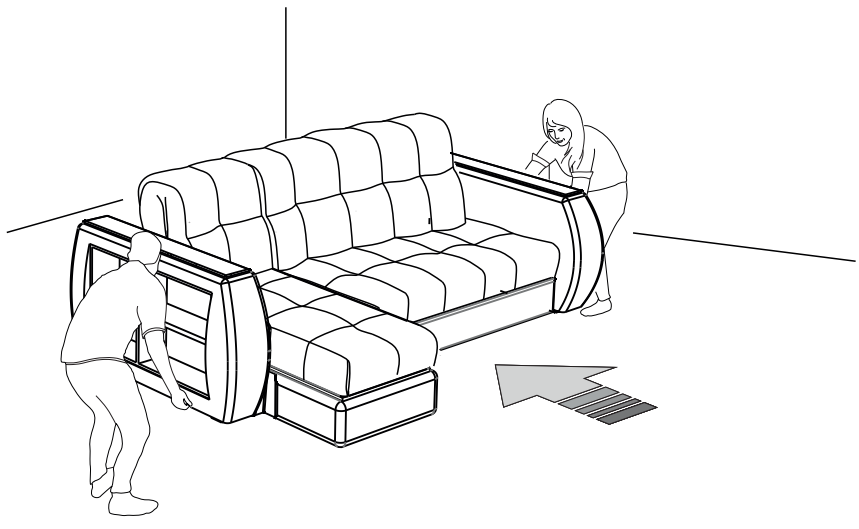

Stellen Sie das Sofa an einem Ort auf, an dem es dauerhaft genutzt wird

44)

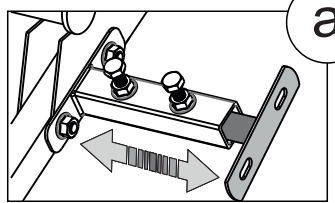
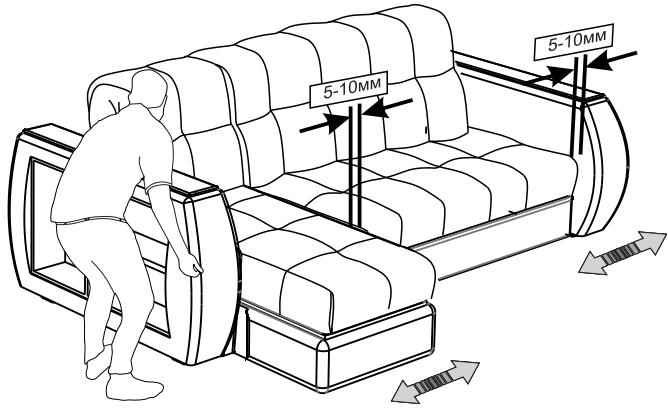

a

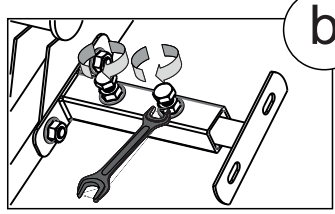

b

festziehen!

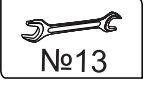

45)

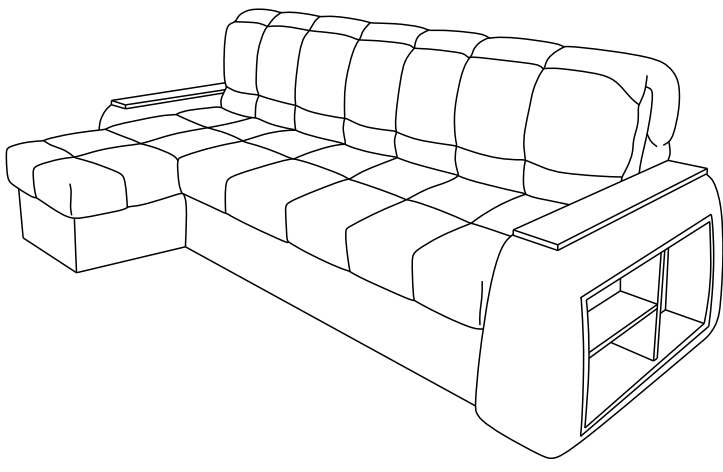

Die Reihenfolge der Transformation des Sofas

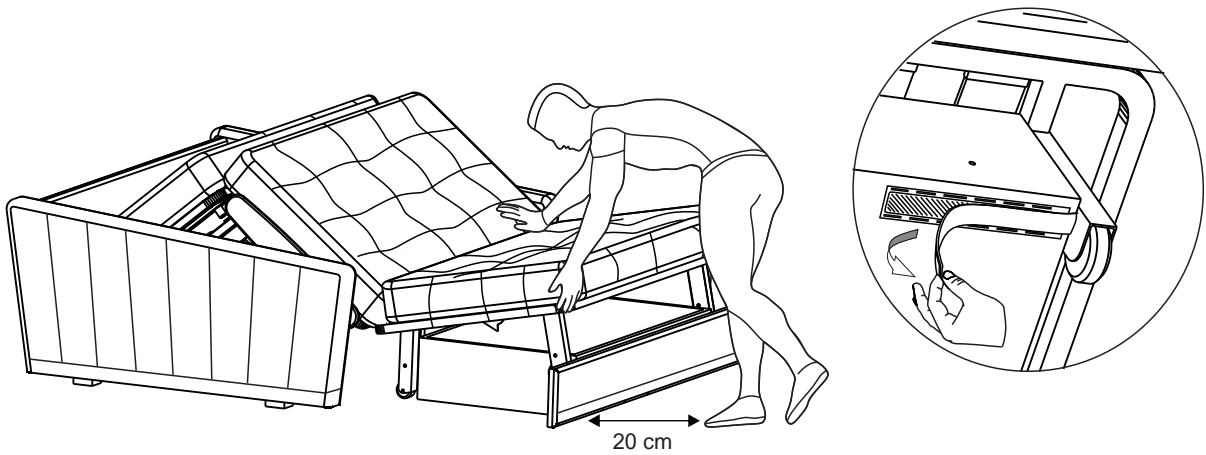
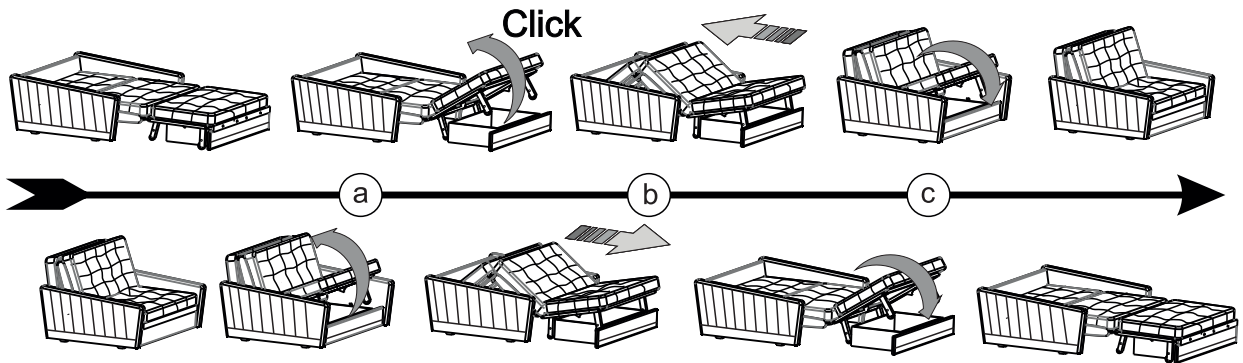

Wenn sich der Sofasitz nicht anheben lässt, lösen Sie den Transportklettverschluss

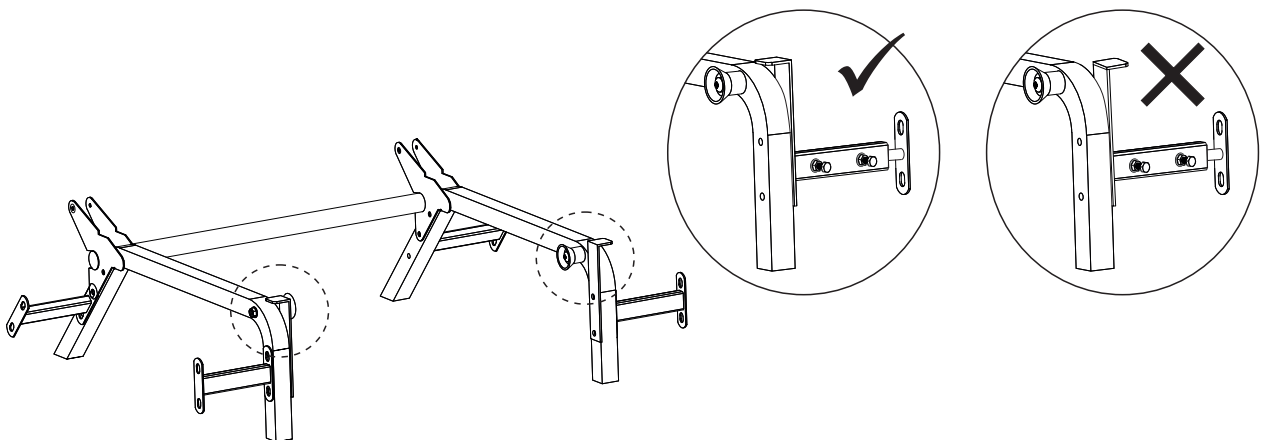

Wenn sich der Sofasitz nicht bewegt, überprüfen Sie die Position der Stützen am Mechanismus

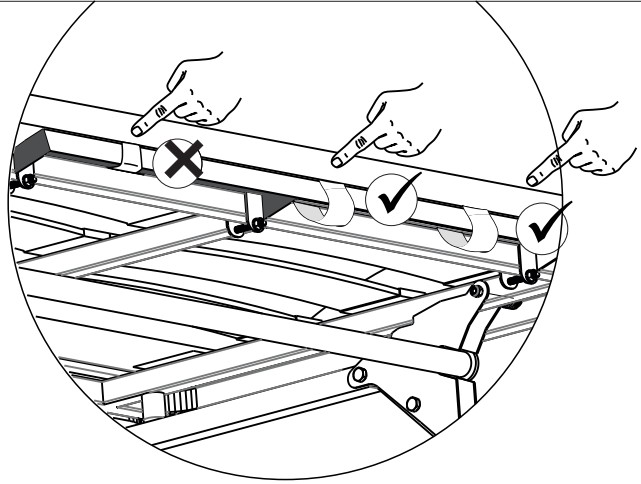
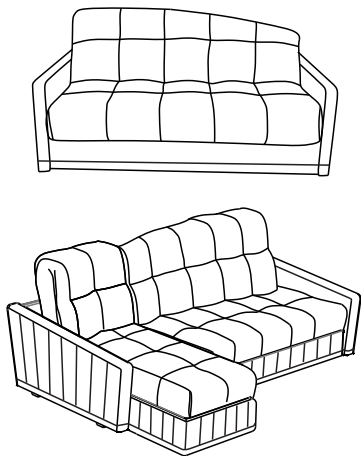

Wenn die Rückseite des Sofas schief steht, lösen Sie die Kontaktbänder am Kopfende

Wenn zwischen Matratze und Armlehne ein großer Spalt besteht, heben Sie den Sitzbereich an und lösen Sie die Kontaktbänder

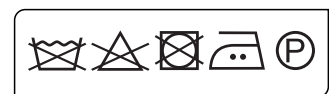
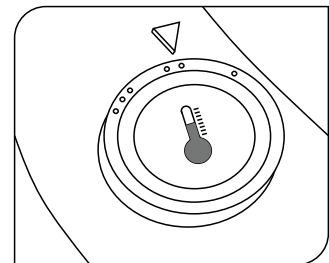
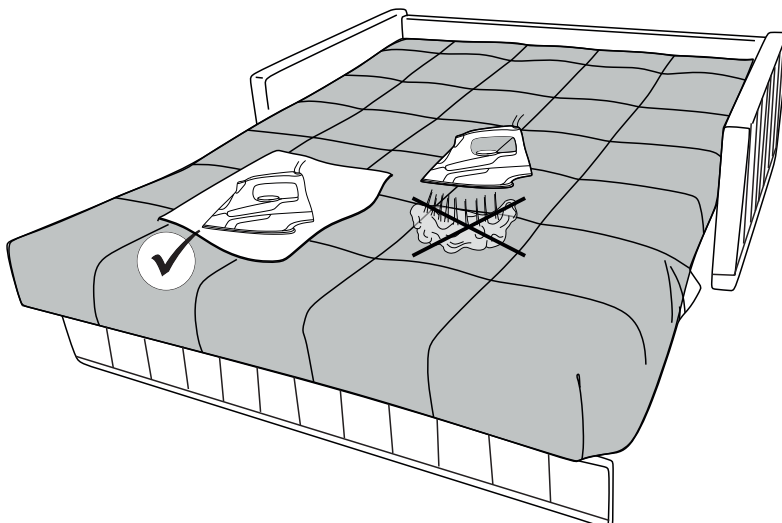
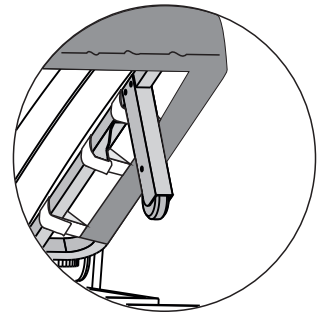
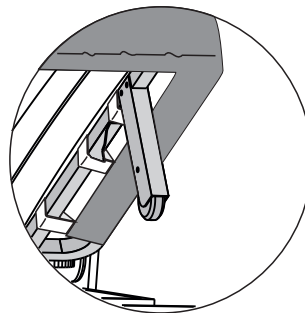
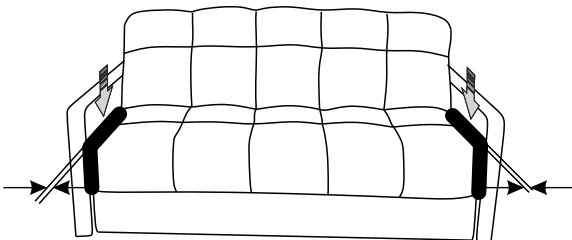
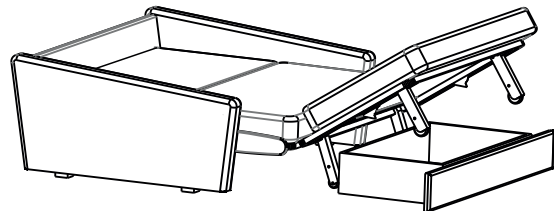

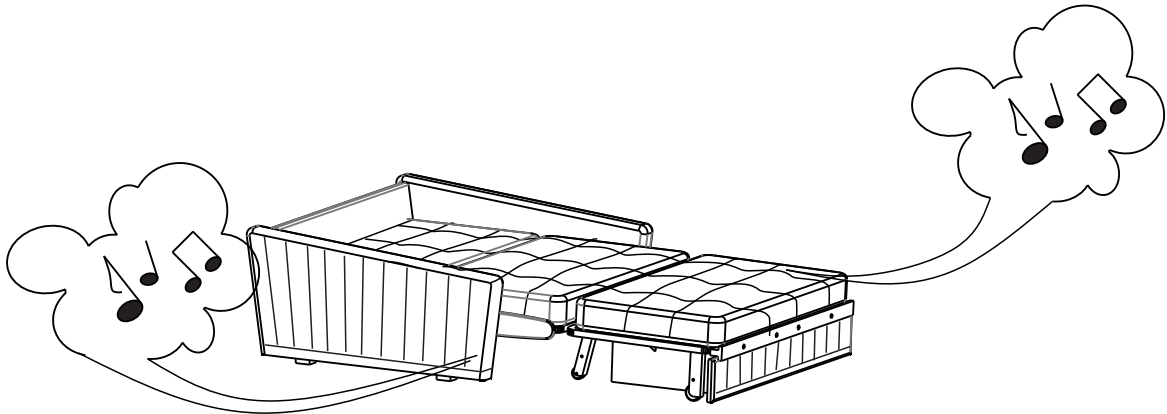

Denken Sie daran: Das charakteristische Knarren der Metallelemente des Mechanismus während der ständigen Transformation ist eine normale Situation. Das Herzstück des Sofas ist eine zuverlässige Metallstruktur, die es Ihnen ermöglicht, das Sofa jeden Tag in ein Bett zu verwandeln. Im Laufe der Umwandlung und des Betriebs kann das Schmiermittel zwischen verschiedenen Teilen des Mechanismus austrocknen und es kommt zu Reibung von Metallelementen aneinander. Um diese Reibung und das Knarren des Mechanismus während der Transformation oder des Betriebs zu vermeiden, ist es wichtig, die folgenden Empfehlungen zu beachten: Wenn ein Knarren auftritt, schmieren Sie die Reibelemente des Mechanismus und dehnen Sie die Verbindungen. Schmieren Sie mindestens alle 6 Monate.

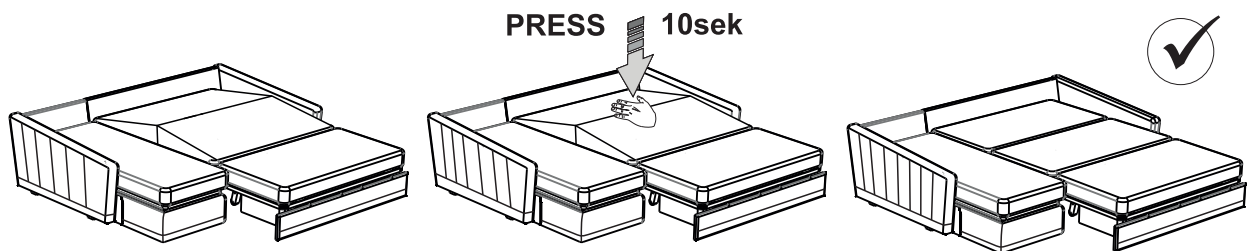
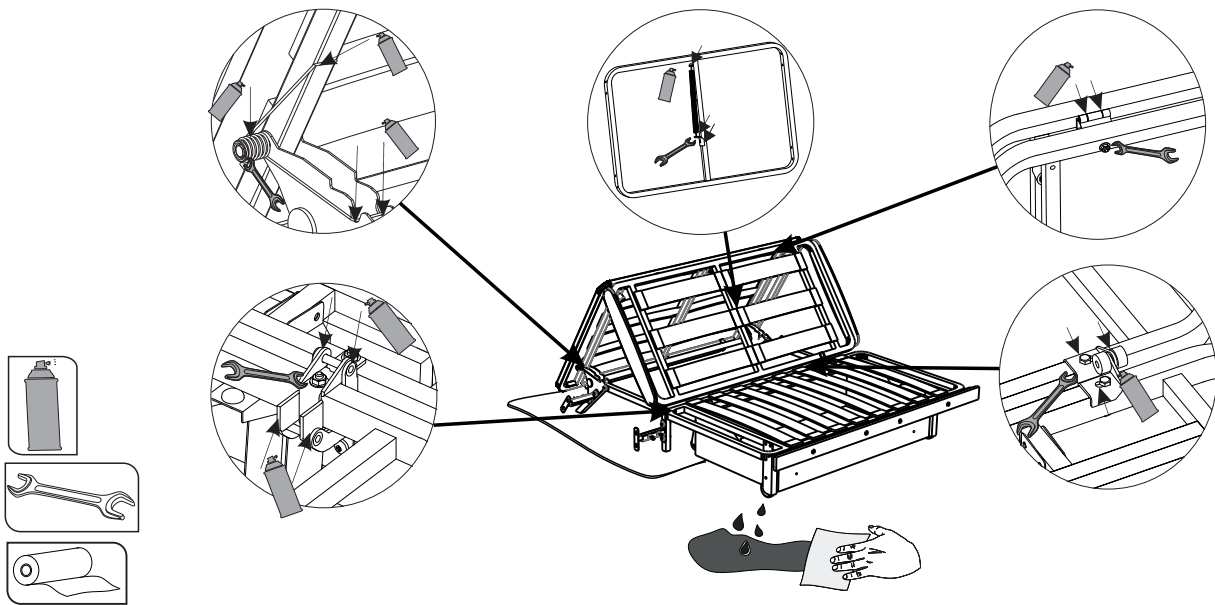

10 Sekunden lang drücken

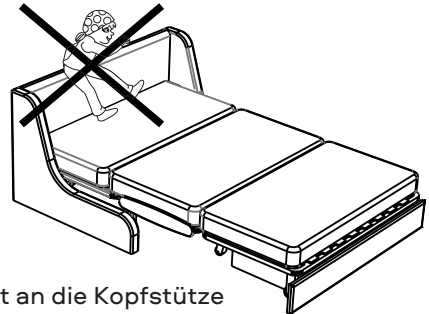
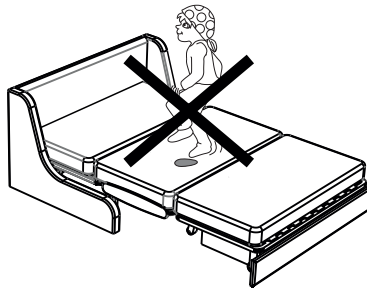
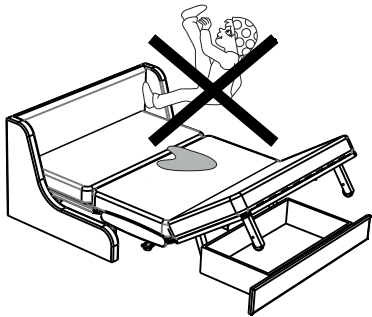
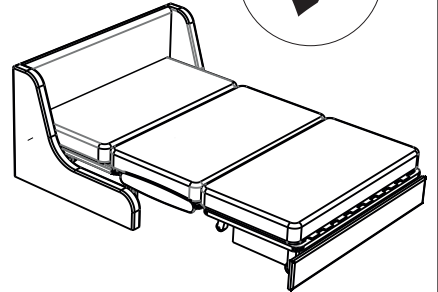
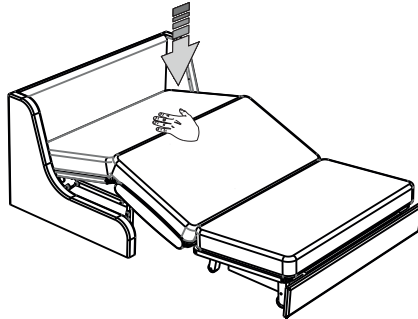
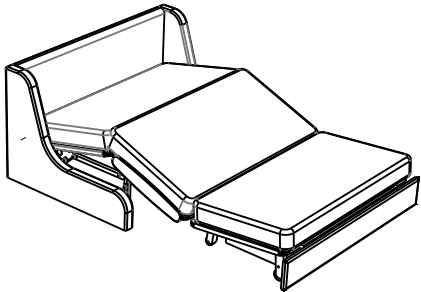

Setzen Sie sich nicht an die Kopfstütze

